



**SERIES 23H**  
**AC Servo Control**

**Installation & Operating Manual**

# Table of Contents

---

<b>Section 1</b>	
<b>Quick Start Guide</b> .....	1-1
<b>Section 2</b>	
<b>General Information</b> .....	2-1
Overview .....	2-1
Limited Warranty .....	2-2
Safety Notice .....	2-3
<b>Section 3</b>	
<b>Receiving &amp; Installation</b> .....	3-1
Receiving & Inspection .....	3-1
Physical Location .....	3-1
Control Installation .....	3-2
Keypad Installation Procedure .....	3-2
Optional Remote Keypad Installation .....	3-3
Electrical Installation .....	3-4
System Grounding .....	3-4
Line Impedance .....	3-5
Line Reactors .....	3-5
Load Reactors .....	3-5
AC Main Circuit Considerations .....	3-6
Protection Devices .....	3-6
Power Disconnect .....	3-6
Wire Size and Protection Devices .....	3-6
AC Line Connections .....	3-8
Reduced Input Voltage Derating .....	3-8
380-400 VAC Operation .....	3-8
Three Phase Input Power .....	3-9
Single Phase Input Power Considerations .....	3-11
Single Phase Control Derating .....	3-11
Size A, B and B2 Single Phase Power Installation .....	3-11
Size C2 Single Phase Power Installation .....	3-12
Size C and D Single Phase Power Installation .....	3-13
Size D2 Single Phase Power Installation .....	3-14
Size E Single Phase Power Installation .....	3-15
Size F Single Phase Power Installation .....	3-16
Motor Connections .....	3-17
M-Contactor .....	3-17
Optional Dynamic Brake Hardware .....	3-18
Electrical Installation .....	3-18
Resolver Feedback .....	3-20
Simulated Encoder Output .....	3-21
Home (Orient) Switch Input .....	3-22

---

Operating Modes .....	3-23
Analog Inputs .....	3-24
Analog Outputs .....	3-26
Serial Operating Mode .....	3-26
Keypad Operating Mode .....	3-27
Standard Run 3 Wire Operating Mode .....	3-28
15 Speed 2-Wire Operating Mode .....	3-29
3 Speed Analog 2 Wire Operating Mode .....	3-30
3 Speed Analog 3 Wire Operating Mode .....	3-31
Bipolar Speed or Torque Operating Mode .....	3-32
Multiple Parameter Sets .....	3-33
Process Operating Mode .....	3-34
Electronic Pot 2 Wire Operating Mode .....	3-35
Electronic Pot 3 Wire Control Mode .....	3-36
External Trip Input .....	3-36
Opto-Isolated Inputs .....	3-37
Opto-Isolated Outputs .....	3-38
Pre-Operation Checklist .....	3-39
Power-Up Procedure .....	3-40
<b>Section 4</b>	
<b>Programming and Operation</b> .....	4-1
Overview .....	4-1
Display Mode .....	4-2
Adjusting Display Contrast .....	4-2
Display Mode Screens .....	4-2
Diagnostic Information Access .....	4-3
Fault Log Access .....	4-4
Program Mode .....	4-5
Parameter Blocks Access for Programming .....	4-5
Changing Parameter Values when Security Code Not Used .....	4-6
Reset Parameters to Factory Settings .....	4-7
Initialize New Software .....	4-8
Parameter Definitions .....	4-9

---

<b>Section 5</b>	
<b>Troubleshooting</b>	5-1
Overview	5-1
No Keypad Display - Display Contrast Adjustment	5-1
How to Access Diagnostic Information	5-2
How to Access the Fault Log	5-3
How to Clear the Fault Log	5-3
Resolver Troubleshooting	5-5
Electrical Noise Considerations	5-11
Relay and Contactor Coils	5-11
Wires between Controls and Motors	5-11
Special Drive Situations	5-12
Control Enclosures	5-12
Special Motor Considerations	5-12
Analog Signal Wires	5-12
<b>Section 6</b>	
<b>Manual Tuning the Series 23H Control</b>	6-1
Manually Tuning the Control	6-1
Current Prop Gain Parameter	6-1
Current INT Gain Parameter	6-1
Speed Prop Gain Parameter	6-1
Speed Int Gain Parameter	6-2
PI Controller	6-2
<b>Section 7</b>	
<b>Specifications, Ratings &amp; Dimensions</b>	7-1
Specifications	7-1
Operating Conditions	7-1
Resolver Feedback	7-1
Keypad Display	7-2
Control Specifications	7-2
Differential Analog Input	7-2
Analog Outputs	7-3
Digital Inputs	7-3
Digital Outputs	7-3
Diagnostic Indications	7-3
Ratings	7-4
Terminal Tightening Torque Specifications	7-5

---

Dimensions .....	7-6
Size A Control .....	7-6
Size B Control .....	7-7
Size B2 Control .....	7-8
Size C Control .....	7-9
Size C2 Control .....	7-10
Size C2 Control – Through–Wall Mounting .....	7-11
Size D Control .....	7-12
Size D2 Control .....	7-13
Size D2 Control – Through–Wall Mounting .....	7-14
Size E Control .....	7-15
Size F Control .....	7-16
Size G Control .....	7-17
<b>Appendix A</b> .....	A-1
Dynamic Braking (DB) Hardware .....	A-1
RGA Assemblies .....	A-4
RBA Assemblies .....	A-5
RTA Assemblies .....	A-6
<b>Appendix B</b> .....	B-1
Parameter Values .....	B-1
<b>Appendix C</b> .....	C-1
Remote Keypad Mounting Template .....	C-2

# Section 1

## Quick Start Guide

---

### Overview

If you are an experienced user of Baldor controls, you are probably already familiar with the keypad programming and keypad operation methods. If so, this quick start guide has been prepared for you. This procedure will help get your system up and running in the Keypad mode quickly. This will allow motor and control operation to be verified. This procedure assumes that the control, motor and dynamic brake hardware are correctly installed (see Section 3 for procedures) and that you have an understanding of the keypad programming & operation procedures. It is not necessary to wire the terminal strip to operate in the keypad mode (Section 3 describes terminal strip wiring procedures). The quick start procedure is as follows:

1. Read the Safety Notice and Precautions in section 2 of this manual.
2. Mount the control. Refer to Section 3 “Physical Location” procedure.
3. Connect AC power, refer to Section 3 “Three Phase Motor and Control Connections”.
4. Connect the motor, refer to Section 3 “Three Phase Motor and Control Connections”.
5. Connect the resolver, refer to Section 3 “Resolver Feedback”.
6. Install dynamic brake hardware, if required. Refer to Section 3 “Optional Dynamic Brake Hardware”.
7. Connect the keypad to the keypad connector of the main control board. Refer to Section 3 “Keypad Installation Procedure”.

### Quick Start Checklist

Check of electrical items.

**⚠ CAUTION: After completing the installation but before you apply power, be sure to check the following items.**

1. Verify AC line voltage at source matches control rating.
2. Inspect all power connections for accuracy, workmanship and torque as well as compliance to codes.
3. Verify control and motor are grounded to each other and the control is connected to earth ground.
4. Check all signal wiring for accuracy.
5. Be certain all brake coils, contactors and relay coils have noise suppression. This should be an R-C filter for AC coils and reverse polarity diodes for DC coils. MOV type transient suppression is not adequate.

**⚠ WARNING: Make sure that unexpected operation of the motor shaft during start up will not cause injury to personnel or damage to equipment.**

### Check of Motors and Couplings

1. Verify freedom of motion of the motor shaft.
2. Verify that all motor couplings are tight without backlash.
3. Verify the holding brakes if any, are properly adjusted to fully release and set to the desired torque value.

---

## Quick Start Procedure

### **Initial Conditions**

Be sure the 23H control, motor and dynamic brake hardware are installed and wired according to the procedures in Section 3 of this manual.

Become familiar with the keypad programming and keypad operation of the control as described in Section 4 of this manual.

1. Disconnect the load (including coupling or inertia wheels) from the motor shaft, if possible.
2. Verify that any enable inputs to J1-8 are open. Be sure Level 2 Protection block, Local Enable INP is OFF and Level 2 Protection block, External Trip is OFF.
3. Turn power on. Be sure no errors are displayed.
4. Set the Level 1 Input block, Operating Mode parameter to "KEYPAD".
5. Set the Level 2 Output Limits block, "OPERATING ZONE" parameter as desired (STD CONST TQ, STD VAR TQ, QUIET CONST TQ or QUIET VAR TQ).
6. Enter the following motor data in the Level 2 Motor Data block parameters:  
Motor Rated Amps (IC)  
Motor Poles  
Resolver Speeds (Pre-set is one speed)
7. If external dynamic brake hardware is used, set the Level 2 Brake Adjust block "Resistor Ohms" and "Resistor Watts" parameters.
8. If the load was not disconnected in step 1, refer to Section 6 and manually tune the control. After manual tuning, perform steps 11 and 12 then continue with step 16.
9. At the Level 2 Motor Data block, press ENTER, at CALC PRESETS select YES (using the ▲ key) and let the control calculate preset values for the parameters that are necessary for control operation.

**⚠ WARNING: The motor shaft will rotate during the autotune procedure. Be certain that unexpected motor shaft movement will not cause injury to personnel or damage to equipment.**

10. Go to Level 2 Autotune block, and perform the following tests:  
CMD OFFSET TRIM  
CUR LOOP COMP  
RESOLVER ALIGN
11. Set the Level 2 Output Limits block, "MIN OUTPUT SPEED" parameter.
12. Set the Level 2 Output Limits block, "MAX OUTPUT SPEED" parameter.
13. Remove all power from the control.
14. Couple the motor to its load.
15. Turn power on. Be sure no errors are displayed.
16. Perform the SPD CNTRLR CALC test in the Level 2 Autotune block.
17. Run the drive from the keypad using the arrow keys for direct speed control, a keypad entered speed or the JOG mode.
18. Select and program additional parameters to suit your application.

The control is now ready for use the in keypad mode. If a different operating mode is desired, refer to Section 3 Control Connections and Section 4 Programming and Operation.

## Section 2

### General Information

---

#### Overview

The Baldor Series 23H PWM control uses a closed loop control scheme using an algorithm to adjust the phase of voltage and current applied to a three phase permanent magnet synchronous motor. The servo control adjusts the motor current to produce maximum torque from base speed down to and including zero speed. The frequency of the voltage applied to the motor follows the electrical cycles per revolution based on the mechanical speed of the rotor. This provides instantaneous adjustment of the voltage and current phasing in response to speed and position feedback from a resolver mounted to the motors' shaft.



---

### **Limited Warranty**

For a period of two (2) years from the date of original purchase, BALDOR will repair or replace without charge controls and accessories which our examination proves to be defective in material or workmanship. This warranty is valid if the unit has not been tampered with by unauthorized persons, misused, abused, or improperly installed and has been used in accordance with the instructions and/or ratings supplied. This warranty is in lieu of any other warranty or guarantee expressed or implied. BALDOR shall not be held responsible for any expense (including installation and removal), inconvenience, or consequential damage, including injury to any person or property caused by items of our manufacture or sale. (Some states do not allow exclusion or limitation of incidental or consequential damages, so the above exclusion may not apply.) In any event, BALDOR's total liability, under all circumstances, shall not exceed the full purchase price of the control. Claims for purchase price refunds, repairs, or replacements must be referred to BALDOR with all pertinent data as to the defect, the date purchased, the task performed by the control, and the problem encountered. No liability is assumed for expendable items such as fuses.

Goods may be returned only with written notification including a BALDOR Return Authorization Number and any return shipments must be prepaid.

---

## **Safety Notice**

This equipment contains voltages that may be as high as 1000 volts! Electrical shock can cause serious or fatal injury. Only qualified personnel should attempt the start-up procedure or troubleshoot this equipment.

This equipment may be connected to other machines that have rotating parts or parts that are driven by this equipment. Improper use can cause serious or fatal injury. Only qualified personnel should attempt the start-up procedure or troubleshoot this equipment.

### **PRECAUTIONS**

- ⚠ WARNING:** Do not touch any circuit board, power device or electrical connection before you first ensure that power has been disconnected and there is no high voltage present from this equipment or other equipment to which it is connected. Electrical shock can cause serious or fatal injury. Only qualified personnel should attempt the start-up procedure or troubleshoot this equipment.
- ⚠ WARNING:** This unit has an automatic restart feature that will start the motor whenever input power is applied and a RUN (FWD or REV) command is issued. If an automatic restart of the motor could cause injury to personnel, the automatic restart feature should be disabled by changing the Level 2 Miscellaneous block, Restart Auto/Man parameter to Manual.
- ⚠ WARNING:** Do not remove cover for at least five (5) minutes after AC power is disconnected to allow capacitors to discharge. Dangerous voltages are present inside the equipment. Electrical shock can cause serious or fatal injury.
- ⚠ WARNING:** Be sure that you are completely familiar with the safe operation of this equipment. This equipment may be connected to other machines that have rotating parts or parts that are controlled by this equipment. Improper use can cause serious or fatal injury. Only qualified personnel should attempt the start-up procedure or troubleshoot this equipment.
- ⚠ WARNING:** Be sure the system is properly grounded before applying power. Do not apply AC power before you ensure that all grounding instructions have been followed. Electrical shock can cause serious or fatal injury.
- ⚠ WARNING:** Improper operation of control may cause violent motion of the motor shaft and driven equipment. Be certain that unexpected motor shaft movement will not cause injury to personnel or damage to equipment. Certain failure modes of the control can produce peak torque of several times the rated motor torque.
- ⚠ WARNING:** Motor circuit may have high voltage present whenever AC power is applied, even when motor is not rotating. Electrical shock can cause serious or fatal injury.
- ⚠ WARNING:** Dynamic brake resistors may generate enough heat to ignite combustible materials. Keep all combustible materials and flammable vapors away from brake resistors.
- ⚠ WARNING:** The motor shaft will rotate during the autotune procedure. Be certain that unexpected motor shaft movement will not cause injury to personnel or damage to equipment.

Continued on next page

- 
- ⚠ **Caution:** Disconnect motor leads (T1, T2 and T3) from control before you perform a “Megger” test on the motor. Failure to disconnect motor from the control will result in extensive damage to the control. The control is tested at the factory for high voltage / leakage resistance as part of Underwriter Laboratory requirements.
- ⚠ **Caution:** Suitable for use on a circuit capable of delivering not more than the RMS symmetrical short circuit amperes listed here at rated voltage.
- | <u>Horsepower</u> | <u>rms Symmetrical Amperes</u> |
|-------------------|--------------------------------|
| 1–50              | 5,000                          |
| 51–200            | 10,000                         |
| 201–400           | 18,000                         |
| 401–600           | 30,000                         |
| 601–900           | 42,000                         |
- ⚠ **Caution:** Do not supply any power to the External Trip (motor thermostat) leads at J1-16 and 17. Power on these leads can damage the control. Use a dry contact type that requires no external power to operate.
- ⚠ **Caution:** Do not connect AC power to the Motor terminals T1, T2 and T3. Connecting AC power to these terminals may result in damage to the control.
- ⚠ **Caution:** Baldor recommends not using “Grounded Leg Delta” transformer power leads that may create ground loops. Instead, we recommend using a four wire Wye.
- ⚠ **Caution:** If the DB hardware mounting is in any position other than vertical, the DB hardware must be derated by 35% of its rated capacity.
- ⚠ **Caution:** If an M-Contactor is installed, the control must be disabled for at least 20msec before the M-Contactor is opened. If the M-Contactor is opened while the control is supplying voltage and current to the motor, the control may be damaged.
- ⚠ **Caution:** Do not connect any shields to the motor frame. At a minimum, resolver signal integrity will be compromised and damage to the control may result. The resolver shields must be connected at J1-28 only.

## Section 3 Receiving & Installation

### Receiving & Inspection

When you receive your control, there are several things you should do immediately.

1. Observe the condition of the shipping container and report any damage immediately to the commercial carrier that delivered your control.
2. Verify that the part number of the control you received is the same as the part number listed on your purchase order.
3. If the control is to be stored for several weeks before use, be sure that it is stored in a location that conforms to published storage temperature and humidity specifications. (Refer to Section 7 of this manual).

### Physical Location

The mounting location of the control is important. It should be installed in an area that is protected from direct sunlight, corrosives, harmful gases or liquids, dust, metallic particles, shock and vibration.

Several other factors should be carefully evaluated when selecting a location for installation:

1. For effective cooling and maintenance, the control should be mounted vertically on a flat, smooth, non-flammable vertical surface. Table 3-1 lists the Watts Loss ratings for enclosure sizing.
2. At least two inches clearance must be provided on all sides for air flow.
3. Front access must be provided to allow the control cover to be opened or removed for service and to allow viewing of the Keypad Display.  
Controls packaged in a floor mounted enclosure must be positioned with clearance to open the enclosure door. This clearance will also provide sufficient air space for cooling.
4. **Altitude derating.** Up to 3300 feet (1000 meters) no derating required. Above 3300 ft, derate the continuous and peak output current by 2% for each 1000 ft.
5. **Temperature derating.** Up to 40°C no derating required. Above 40°C, derate the continuous and peak output current by 2% per °C. Maximum ambient is 55°C.

**Table 3-1 Series 23H Watts Loss Ratings**

Enclosure Size	230 VAC		460 VAC	
	2.5KHz PWM	8.0KHz PWM	2.5KHz PWM	8.0KHz PWM
A, B and B2	14 Watts/ Amp	17 Watts/ Amp	17 Watts/ Amp	26 Watts/ Amp
C, C2, D, D2, E, and F	12 Watts/ Amp	15 Watts/ Amp	15 Watts/ Amp	23Watts/ Amp
G			15 Watts/ Amp	

---

## **Control Installation**

The control must be securely fastened to the mounting surface at the mounting holes.

### **Shock Mounting**

If the control will be subjected to levels of shock greater than 1G or vibration greater than 0.5G at 10 to 60Hz, the control should be shock mounted.

## **Keypad Installation Procedure**

1. Refer to the optional remote keypad installation procedure and mount the keypad.
2. Connect the keypad cable to the keypad connector on the main control board. Refer to Figure 3-30 for the connector location.

---

**Optional Remote Keypad Installation** The keypad may be remotely mounted using the optional Baldor keypad extension cable. The keypad assembly (white - DC00005A-01; grey - DC00005A-02) comes complete with the screws and gasket required to mount it to an enclosure. When the keypad is properly mounted to a NEMA Type 4X enclosure, it retains the Type 4X rating.

**Tools Required:**

- Center punch, tap handle, screwdrivers (Phillips and straight) and crescent wrench.
- 8-32 tap and #29 drill bit (for tapped mounting holes) or #19 drill (for clearance mounting holes).
- 1-1/4" standard knockout punch (1-11/16" nominal diameter).
- RTV sealant.
- (4) 8-32 nuts and lock washers.
- Extended 8-32 screws (socket fillister) are required if the mounting surface is thicker than 12 gauge and is not tapped (clearance mounting holes).
- Remote keypad mounting template. A tear out copy is provided at the end of this manual for your convenience.

**Mounting Instructions: For tapped mounting holes**

1. Locate a flat 4" wide x 5.5" minimum high mounting surface. Material should be sufficient thickness (14 gauge minimum).
2. Place the template on the mounting surface or mark the holes as shown.
3. Accurately center punch the 4 mounting holes (marked A) and the large knockout (marked B).
4. Drill four #29 mounting holes (A). Thread each hole using an 8-32 tap.
5. Locate the 1-1/4" knockout center (B) and punch using the manufacturers instructions.
6. Debur knockout and mounting holes making sure the panel stays clean and flat.
7. Apply RTV to the 4 holes marked (A).
8. Assemble the keypad to the panel. Use 8-32 screws, nuts and lock washers.
9. From the inside of the panel, apply RTV over each of the four mounting screws and nuts. Cover a 3/4" area around each screw while making sure to completely encapsulate the nut and washer.

**Mounting Instructions: For clearance mounting holes**

1. Locate a flat 4" wide x 5.5" minimum high mounting surface. Material should be sufficient thickness (14 gauge minimum).
2. Place the template on the mounting surface or mark the holes as shown on the template.
3. Accurately center punch the 4 mounting holes (marked A) and the large knockout (marked B).
4. Drill four #19 clearance holes (A).
5. Locate the 1-1/4" knockout center (B) and punch using the manufacturers instructions.
6. Debur knockout and mounting holes making sure the panel stays clean and flat.
7. Apply RTV to the 4 holes marked (A).
8. Assemble the keypad to the panel. Use 8-32 screws, nuts and lock washers.
9. From the inside of the panel, apply RTV over each of the four mounting screws and nuts. Cover a 3/4" area around each screw while making sure to completely encapsulate the nut and washer.

## Electrical Installation

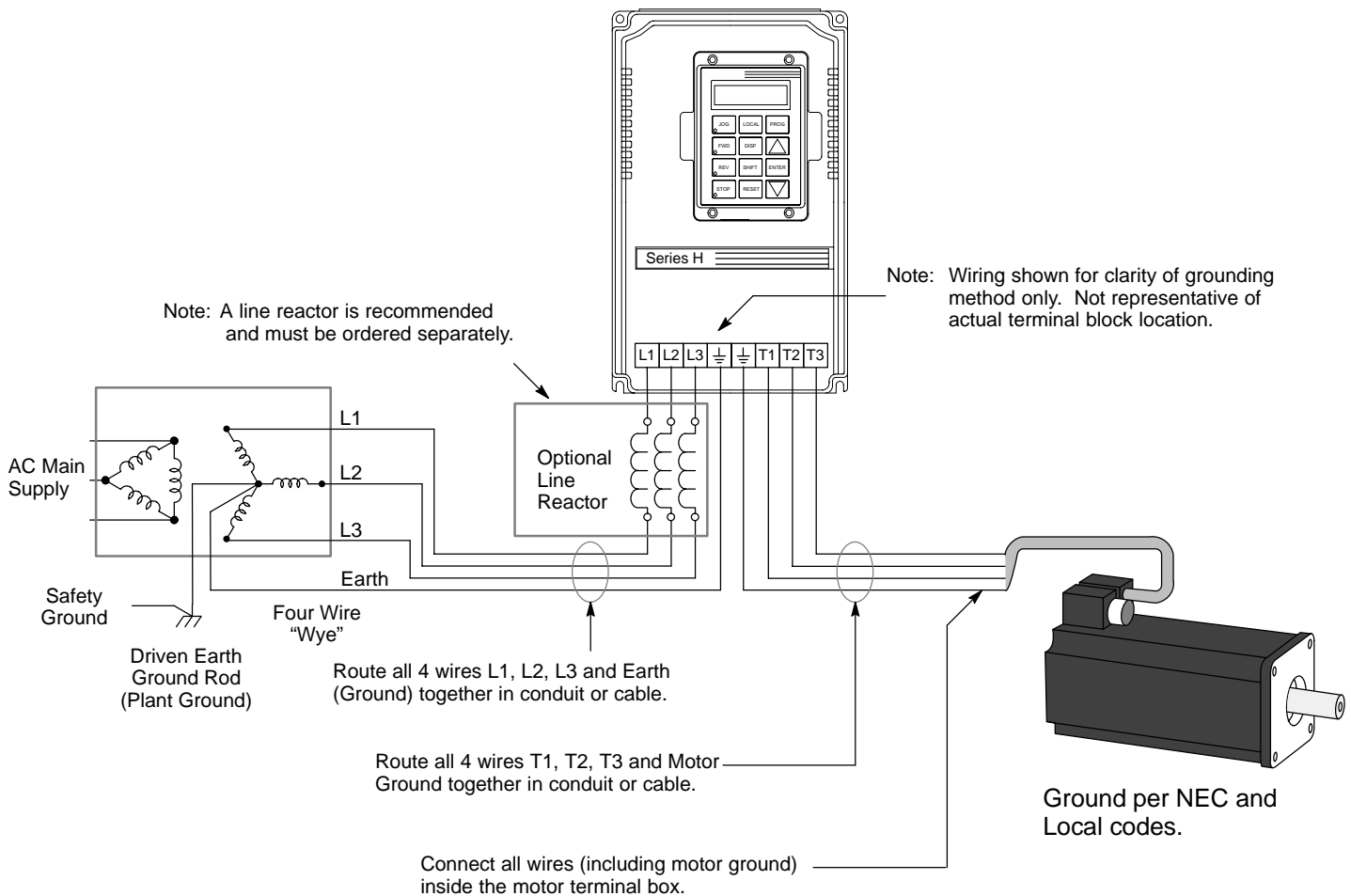
Interconnection wiring is required between the motor control, AC power source, motor, host control and any operator interface stations. Use listed closed loop connectors that are of appropriate size for wire gauge being used. Connectors are to be installed using crimp tool specified by the manufacturer of the connector. Only Class 1 wiring should be used.

Baldor Series H controls feature UL approved adjustable motor overload protection suitable for motors rated at no less than 50% of the output rating of the control. Other governing agencies such as NEC may require separate over-current protection. The installer of this equipment is responsible for complying with the National Electric Code and any applicable local codes which govern such practices as wiring protection, grounding, disconnects and other current protection.

## System Grounding

Baldor Controls are designed to be powered from standard three phase lines that are electrically symmetrical with respect to ground. System grounding is an important step in the overall installation to prevent problems. The recommended grounding method is shown in Figure 3-1.

**Figure 3-1 Recommended System Grounding**



**Ungrounded Distribution System**

With an ungrounded power distribution system it is possible to have a continuous current path to ground through the MOV devices. To avoid equipment damage, an isolation transformer with a grounded secondary is recommended. This provides three phase AC power that is symmetrical with respect to ground.

**Input Power Conditioning**

Baldor controls are designed for direct connection to standard three phase lines that are electrically symmetrical with respect to ground. Certain power line conditions must be avoided. An AC line reactor or an isolation transformer may be required for some power conditions.

- If the feeder or branch circuit that provides power to the control has permanently connected power factor correction capacitors, an input AC line reactor or an isolation transformer must be connected between the power factor correction capacitors and the control.
- If the feeder or branch circuit that provides power to the control has power factor correction capacitors that are switched on line and off line, the capacitors must not be switched while the control is connected to the AC power line. If the capacitors are switched on line while the control is still connected to the AC power line, additional protection is required. TVSS (Transient Voltage Surge Suppressor) of the proper rating must be installed between the AC line reactor or an isolation transformer and the AC input to the control.

**Line Impedance**

The Baldor control requires a minimum line impedance. If the impedance of the incoming power does not meet the requirement for the control, a 3 phase line reactor can be used to provide the needed impedance in most cases. Line reactors are optional and are available from Baldor.

Control Size	A, B, C, D, E	B2, C2, D2, F, G
Line Impedance Required	<b>3%</b>	<b>1%</b>

The input impedance of the power lines can be determined as follows:

Measure the line to line voltage at no load and at full rated load.  
Use these measured values to calculate impedance as follows:

$$\% \text{Impedance} = \frac{(\text{Volts}_{\text{No Load Speed}} - \text{Volts}_{\text{Full Load Speed}})}{(\text{Volts}_{\text{No Load Speed}})} \times 100$$

**Line Reactors**

Three phase line reactors are available from Baldor. The line reactor to order is based on the full load current of the motor (FLA). If providing your own line reactor, use the following formula to calculate the minimum inductance required.

$$L = \frac{(V_{L-L} \times 0.03)}{(I \times \sqrt{3} \times 377)}$$

- Where:
- L Minimum inductance in Henries.
  - $V_{L-L}$  Input volts measured line to line.
  - 0.03 Desired percentage of input impedance.
  - I Input current rating of control.
  - 377 Constant used with 60Hz power.  
Use 314 if input power is 50Hz.

**Load Reactors**

Line reactors may be used at the control output to the motor. When used this way, they are called Load Reactors. Load reactors serve several functions that include:

- Protect the control from a short circuit at the motor.
- Limit the rate of rise of motor surge currents.
- Slowing the rate of change of power the control delivers to the motor.

Load reactors should be installed as close to the control as possible. Selection should be based on the motor nameplate FLA value.



## AC Main Circuit Considerations

### Protection Devices

Be sure a suitable input power protection device is installed. Use the recommended circuit breaker or fuses listed in Tables 3-2 through 3-3 (Wire Size and Protection Devices). Input and output wire size is based on the use of copper conductor wire rated at 75 °C. The table is specified for NEMA B motors.

Circuit Breaker:	1 phase, thermal magnetic. Equal to GE type THQ or TEB for 230 VAC
	3 phase, thermal magnetic. Equal to GE type THQ or TEB for 230 VAC or GE type TED for 460 VAC.
Fast Action Fuses:	230 VAC, Buss KTN 460 VAC, Buss KTS to 600A (KTU 601 - 1200A)
Very Fast Action:	230 VAC, Buss JJN 460 VAC, Buss JJS
Time Delay Fuses:	230 VAC, Buss FRN 460 VAC, Buss FRS to 600A (KLU 601 - 1200A)

### Power Disconnect

A power disconnect should be installed between the input power service and the control for a fail safe method to disconnect power. The control will remain in a powered-up condition until all input power is removed from the control and the internal bus voltage is depleted.

## Wire Size and Protection Devices

**Table 3-2 230VAC Controls (3 Phase) Wire Size and Protection Devices**

Control Output Rating		Input Breaker (Amps)	Input Fuse (Amps)		Wire Gauge	
Amps	HP		Fast Acting	Time Delay	AWG	mm <sup>2</sup>
3	0.75		5	4	14	2.5
4	1		6	5	14	2.5
7	2		10	9	14	2.5
10	3		15	12	14	2.5
16	5		25	20	12	3.31
22	7.5		30	30	10	5.26
28	10	40	45	35	8	8.37
42	15	60	70	60	6	13.3
54	20	70	80	70	6	13.3
68	25	90	100	90	4	21.2
80	30	100	125	110	3	26.7
104	40	150	175	150	1	42.4
130	50	175	200	175	1/0	53.5
145	60	200	225	200	2/0	67.4
192	75	250	300	250	4/0	107.0

Note: All wire sizes are based on 75°C copper wire. Higher temperature smaller gauge wire may be used per NEC and local codes. Recommended fuses/breakers are based on 40°C ambient, maximum continuous control output current and no harmonic current.

**Table 3-3 460VAC Controls (3 Phase) Wire Size and Protection Devices**

Control Output Rating		Input Breaker (Amps)	Input Fuse (Amps)		Wire Gauge	
Amps	HP		Fast Acting	Time Delay	AWG	mm <sup>2</sup>
2	0.75		2	2	14	2.5
2	1		3	2.5	14	2.5
4	2		6	5	14	2.5
5	3		8	7	14	2.5
8	5		12	10	14	2.5
11	7.5		20	15	14	2.5
14	10		25	20	12	3.31
21	15	30	30	25	10	5.26
27	20	40	40	35	10	5.26
34	25	50	50	45	8	8.37
40	30	50	60	50	8	8.37
52	40	70	80	70	6	13.3
65	50	90	100	90	4	21.2
77	60	100	125	100	3	26.7
96	75	125	150	125	2	33.6
124	100	175	200	175	1/0	53.5

Note: All wire sizes are based on 75°C copper wire. Higher temperature smaller gauge wire may be used per NEC and local codes. Recommended fuses/breakers are based on 40°C ambient, maximum continuous control output current and no harmonic current.

---

## AC Line Connections

**Reduced Input Voltage Derating** All power ratings stated in Section 7 are for the stated nominal AC input voltages (230 or 460VAC). The power rating of the control must be reduced when operating at a reduced input voltage. The amount of reduction is the ratio of the voltage change.

**Examples:**

A 10HP, 230VAC control operating at 208VAC has a reduced power rating of 9.04HP.

$$10\text{HP} \times \frac{208\text{VAC}}{230\text{VAC}} = 9.04\text{HP}$$

Likewise, a 10HP, 460VAC control operating at 380VAC has a reduced power rating of 8.26HP.

$$10\text{HP} \times \frac{380\text{VAC}}{460\text{VAC}} = 8.26\text{HP}$$

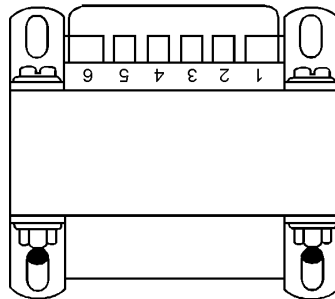
To obtain the full output rating of 10HP in either case requires a 15HP Control.

**380-400 VAC Operation** Size A, B, B2, C2 and D2 460VAC controls may be used directly with a 380-400 VAC power source, control modification is not necessary.

Size C, D, E, F and G 460VAC controls all require modification for operation on the reduced line voltage. Specifically, the control transformer must have the wire on terminal 5 (for 460V) moved to terminal 4 (for 380-400V).

1. Be sure drive operation is terminated and secured.
2. Remove all power sources from the control. If power has been applied, wait at least 5 minutes for bus capacitors to discharge.
3. Remove or open the front cover.
4. Remove the wire from terminal 5.
5. Place the wire that was removed from terminal 5 onto terminal 4.
6. Install or close the front cover.

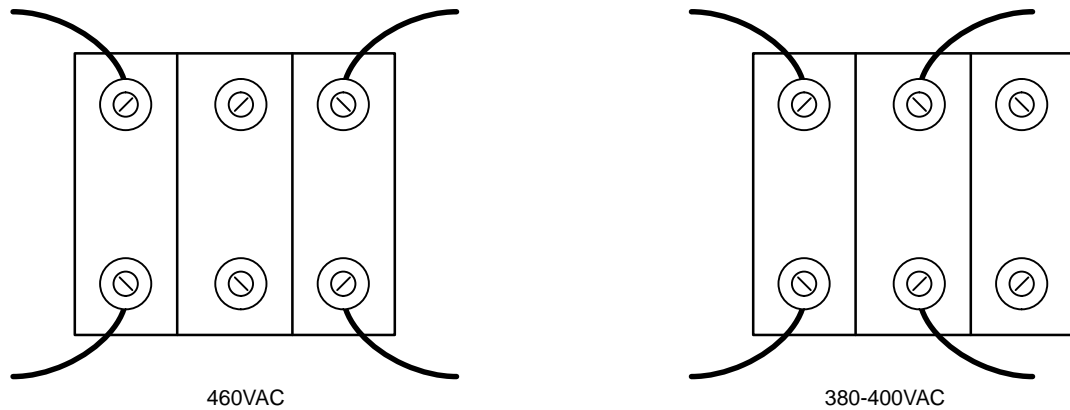
**Figure 3-2 Control Transformer Identification**



Tap Change Procedure (**size G controls**). See Figure 3-3.

1. Be sure drive operation is terminated and control is disabled.
2. Remove all power sources from the control. If power has been applied, wait at least 5 minutes for bus capacitors to discharge.
3. Remove or open the front cover and locate the control transformer (Figure 3-3).
4. Remove the wires from the two right side terminals.
5. Place the wires on the center terminals as shown.
6. Install or close the front cover.

**Figure 3-3 Size G - Control Transformer Terminal Block**

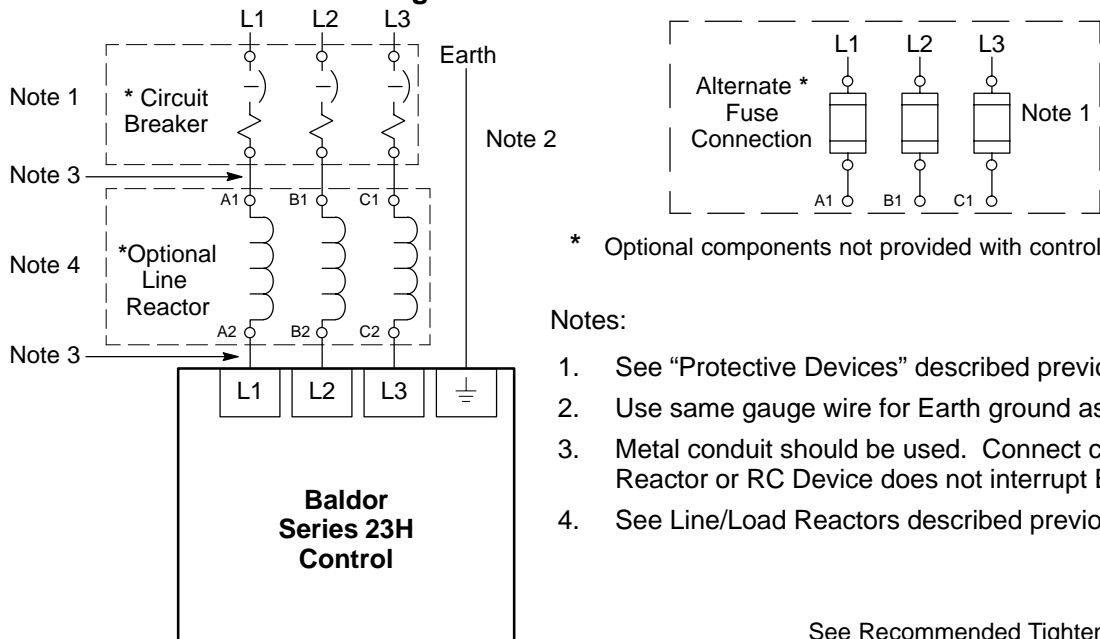


**Three Phase Input Power**

Three phase AC power connections are shown in Figure 3-4. The 23H control has an electronic I<sup>2</sup>t motor overload protection. If motor overloads are desired, they should be sized according to the manufacturers specifications and installed between the motor and the T1, T2 and T3 terminals of the control.

Note: Use same gauge wire for earth ground as is used for L1, L2 and L3 connections. Refer to the wire size and protection devices tables shown previously in this section.

**Figure 3-4 Three Phase AC Power Connections**



\* Optional components not provided with control.

**Notes:**

1. See "Protective Devices" described previously in this section.
2. Use same gauge wire for Earth ground as is used for L1, L2 and L3.
3. Metal conduit should be used. Connect conduits so the use of a Reactor or RC Device does not interrupt EMI/RFI shielding.
4. See Line/Load Reactors described previously in this section.

See Recommended Tightening Torques in Section 7.

Table 3-4 and 3-5 list the wire size for the input AC power wires. Motor leads should be sized from the 3 phase tables.

**Table 3-4 Single Phase Rating Wire Size and Protection Devices - 230 VAC Controls\***

Control Output Rating		Input Breaker (Amps)	Input Fuse (Amps)		Wire Gauge	
Amps	HP		Fast Acting	Time Delay	AWG	mm <sup>2</sup>
6.9	0.75		10	9	14	2.5
8.0	1		12	10	14	2.5
12	2		20	17.5	14	2.5
17	3		25	25	12	3.31
28	5		45	35	10	5.26
40	7.5		60	50	8	8.37
50	10	70	80	70	6	13.3
68	15	90	110	90	4	21.2
88	20	110	150	125	3	26.7
110	25	150	175	150	2	33.6
136	30	175	200	175	1/0	53.5
176	40	225	250	250	3/0	85.0
216	50	275	350	300	(2) 1/0	(2) 53.5

**Table 3-5 Single Phase Rating Wire Size and Protection Devices - 460 VAC Controls\***

Control Output Rating		Input Breaker (Amps)	Input Fuse (Amps)		Wire Gauge	
Amps	HP		Fast Acting	Time Delay	AWG	mm <sup>2</sup>
3.5	0.75		5	5	14	2.5
4.0	1		6	5.6	14	2.5
6.0	2		10	8	14	2.5
8.5	3		15	12	14	2.5
14	5		20	20	12	3.31
20	7.5		30	25	10	5.26
25	10		40	30	10	5.26
34	15	45	50	45	8	8.37
44	20	60	70	60	8	8.37
55	25	70	80	70	6	13.3
68	30	90	100	90	4	21.2
88	40	110	150	125	3	26.7
108	50	150	175	150	2	33.6

\*Note: All wire sizes are based on 75°C copper wire. Higher temperature smaller gauge wire may be used per NEC and local codes. Recommended fuses/breakers are based on 40°C ambient, maximum continuous control output current and no harmonic current.

**Single Phase Input Power Considerations** Single phase operation of G and H size controls is not possible.

Single phase AC input power can be used to power the control instead of three phase for control sizes A, B, B2, C, C2, D, D2, E and F. The specifications and control sizes are listed in Section 7 of this manual. If single phase power is to be used, the rated Horsepower of the control may have to be reduced (derated). In addition, power wiring and jumper changes are required.

Single phase rating wire size and protection devices are listed in Tables 3-4 and 3-5.

**Single Phase Control Derating:** Single phase power derating requires that the continuous and peak current ratings of the control be reduced by the following percentages:

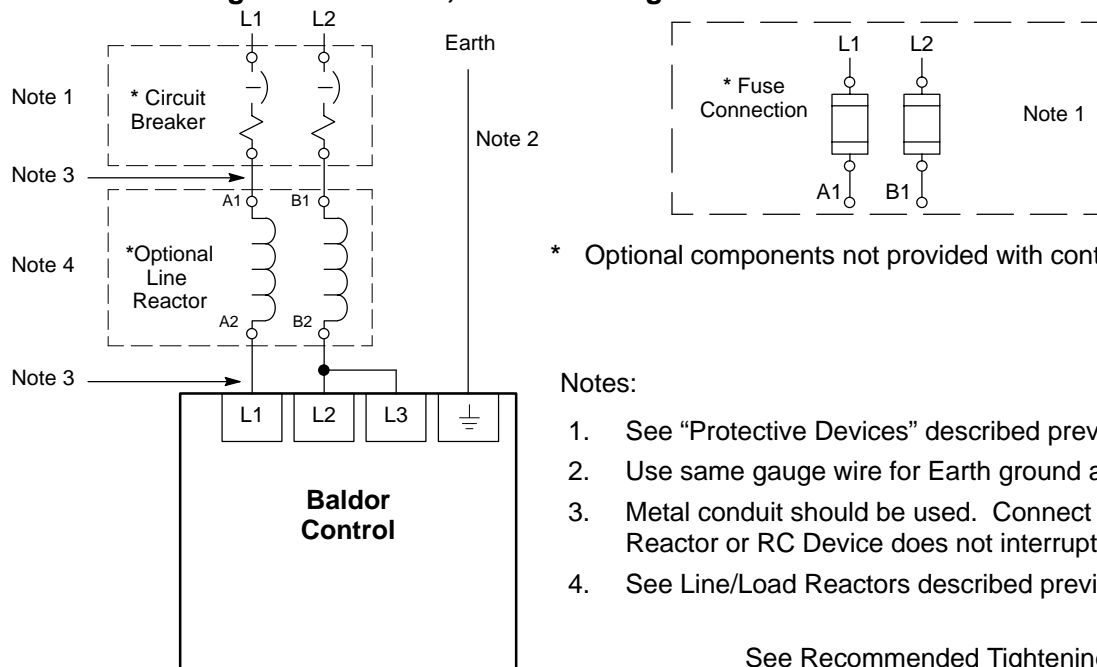
1. **3–10A 230 and 2–5A 460 VAC controls:**  
No derating required.
2. **15–28A (Size B and B2) 230 and 5–15A 460 VAC controls:**  
Derate HP by 40% of the nameplate rating.
3. **42–55A (Size C) and Larger 230 and 460 VAC controls:**  
Derate HP by 50% of the nameplate rating.

**Size A, B and B2 Single Phase Power Installation** (See Figure 3-5.)

**Jumper Configuration**

Size A, B and B2 controls, no jumper changes required.

**Figure 3-5 Size A, B and B2 Single Phase 230/460VAC Power Connections**



\* Optional components not provided with control.

**Notes:**

1. See "Protective Devices" described previously in this section.
2. Use same gauge wire for Earth ground as is used for L1, L2 and L3.
3. Metal conduit should be used. Connect conduits so the use of a Reactor or RC Device does not interrupt EMI/RFI shielding.
4. See Line/Load Reactors described previously in this section.

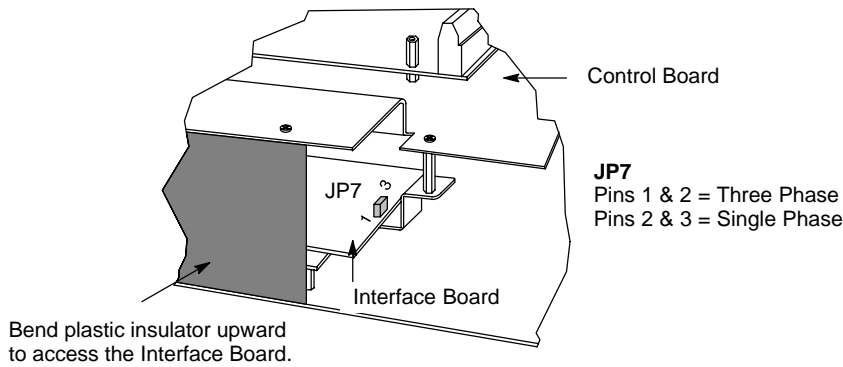
See Recommended Tightening Torques in Section 7.

**Size C2 Single Phase Power Installation** (See Figure 3-7.)

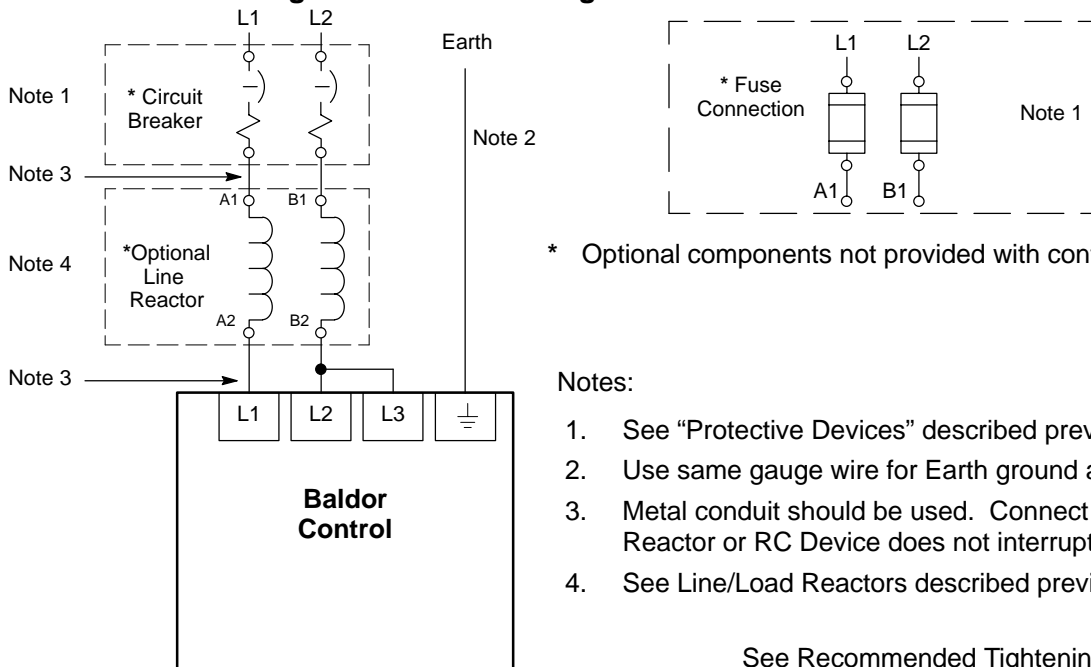
**Jumper Configuration**

Locate the Interface board, and place JP7 on pins 2 & 3 for single phase operation.

**Figure 3-6 Jumper Configuration**



**Figure 3-7 Size C2 Single Phase 230/460VAC Power Connections**

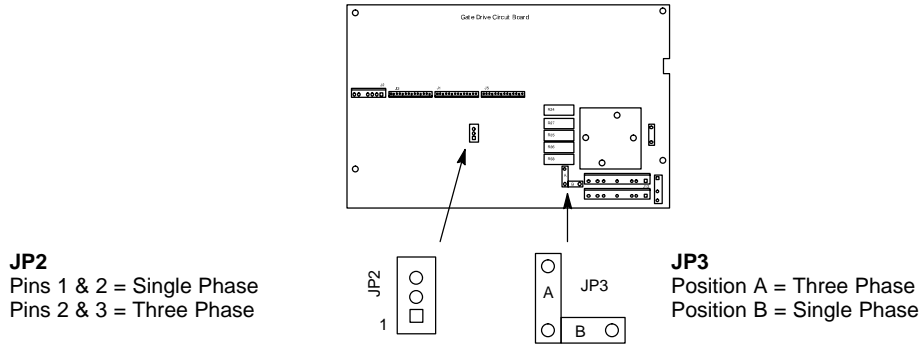


See Recommended Tightening Torques in Section 7.

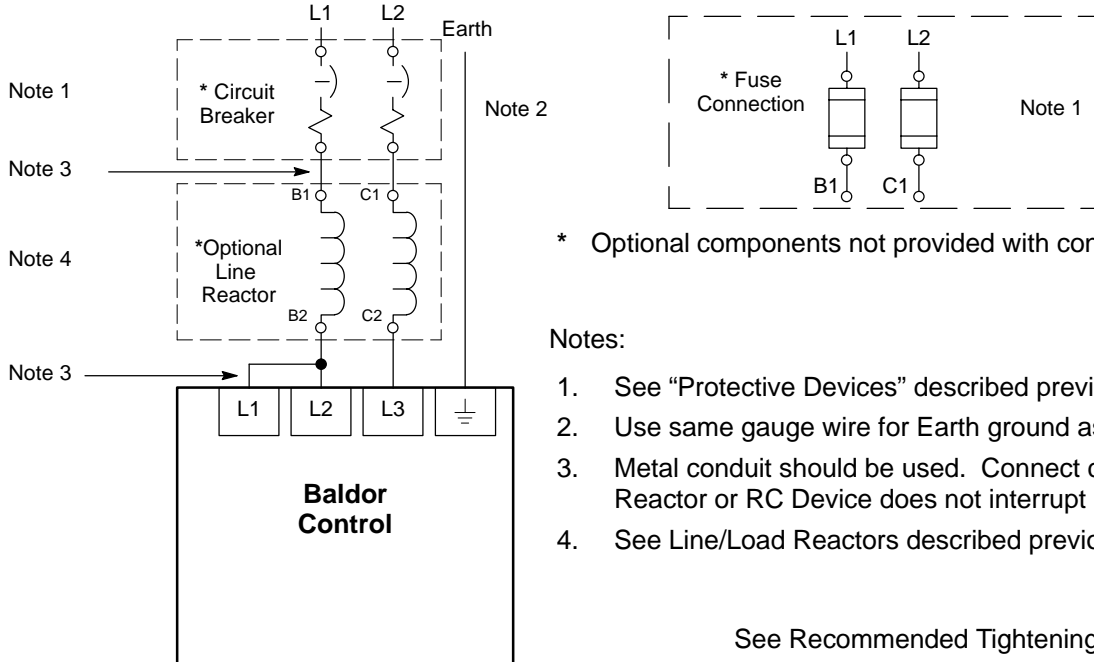
**Size C and D Single Phase Power Installation** (See Figure 3-9.)

**Figure 3-8 Jumper Configuration**

Place JP2 on pins 1 & 2 for control single phase operation.  
Place JP3 in position B for fan single phase operation.



**Figure 3-9 Size C & D Single Phase 230/460VAC Power Connections**



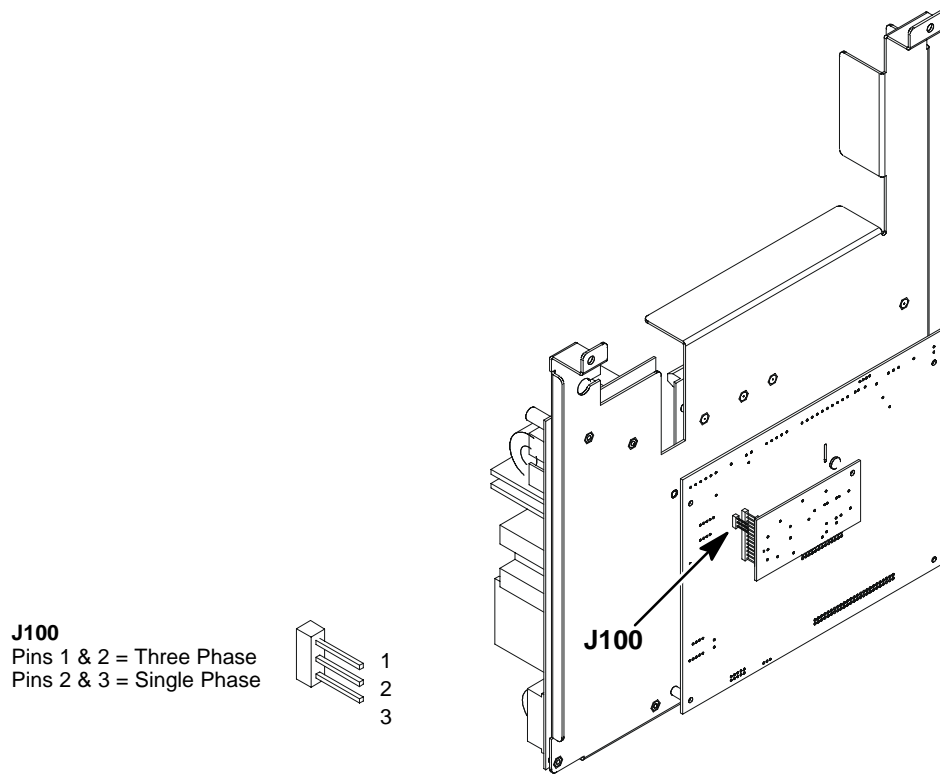


**Size D2 Single Phase Power Installation** (see Figure 3-11)

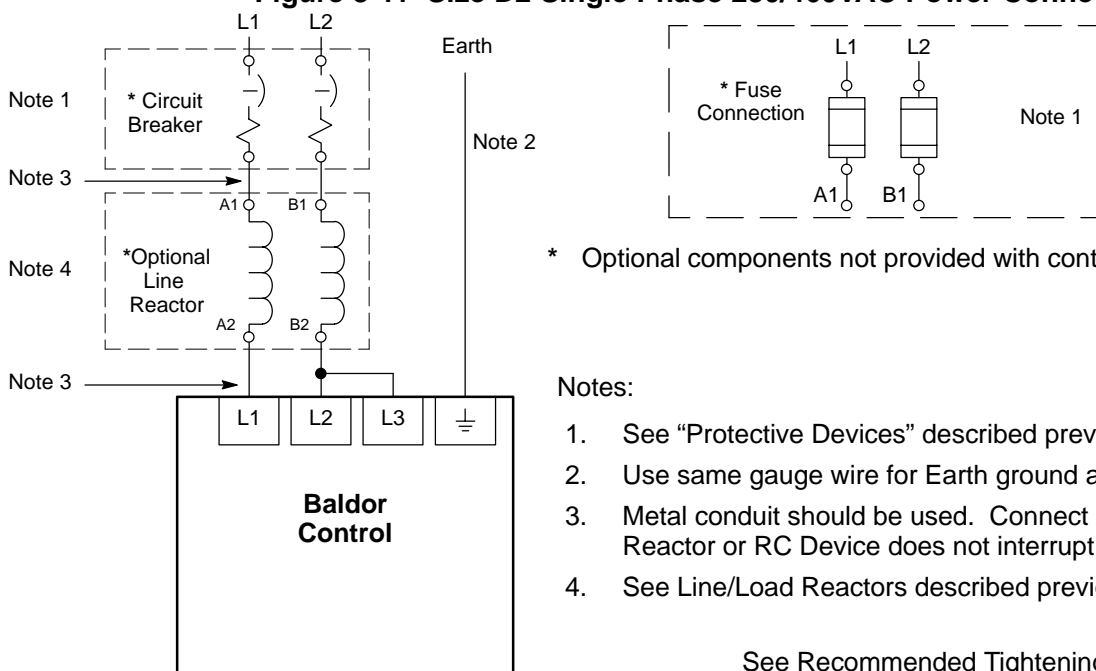
**Jumper Configuration**

Locate the Interface board, and place J100 on pins 2 & 3 for single phase operation.

**Figure 3-10 Jumper Configuration**



**Figure 3-11 Size D2 Single Phase 230/460VAC Power Connections**

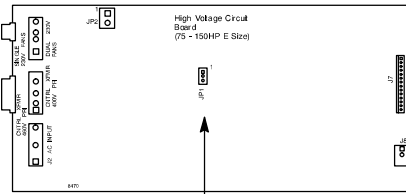


See Recommended Tightening Torques in Section 6.

**Size E Single Phase Power Installation** (See Figure 3-13.)

**Figure 3-12 Jumper Configuration**

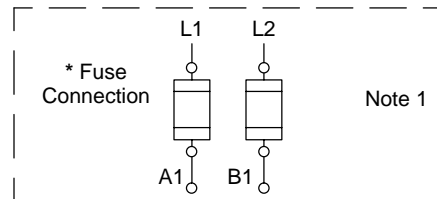
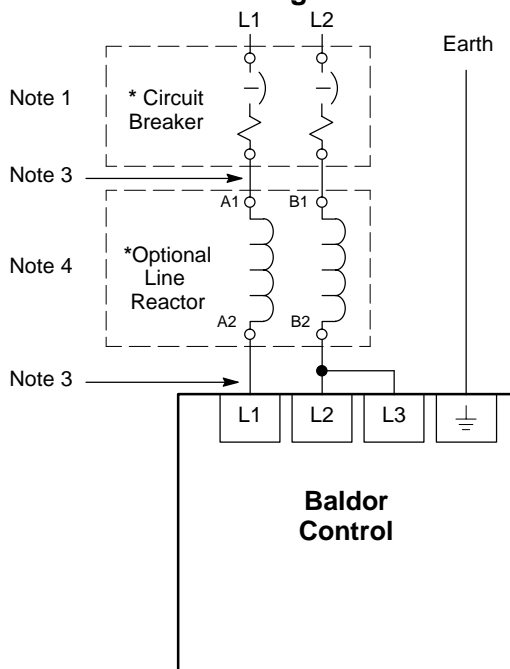
Place JP1 on the High Voltage Circuit Board across pins 1 and 2.



**JP1**  
 Pins 1 & 2 = Single Phase  
 Pins 2 & 3 = Three Phase



**Figure 3-13 Size E Single Phase 230/460VAC Power Connections**



\* Optional components not provided with control.

**Notes:**

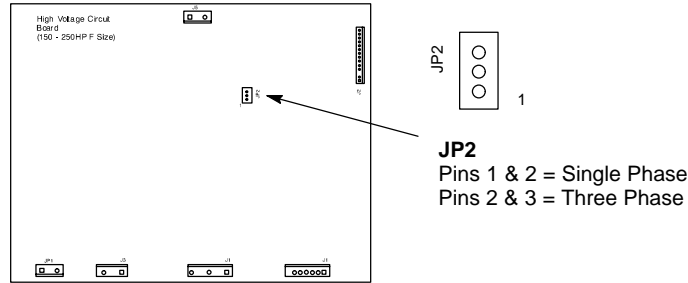
1. See "Protective Devices" described previously in this section.
2. Use same gauge wire for Earth ground as is used for L1, L2 and L3.
3. Metal conduit should be used. Connect conduits so the use of a Reactor or RC Device does not interrupt EMI/RFI shielding.
4. See Line/Load Reactors described previously in this section.

See Recommended Tightening Torques in Section 7.

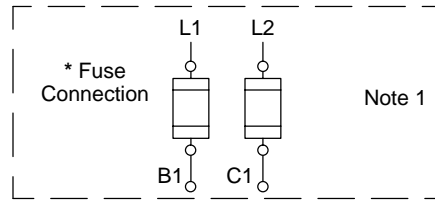
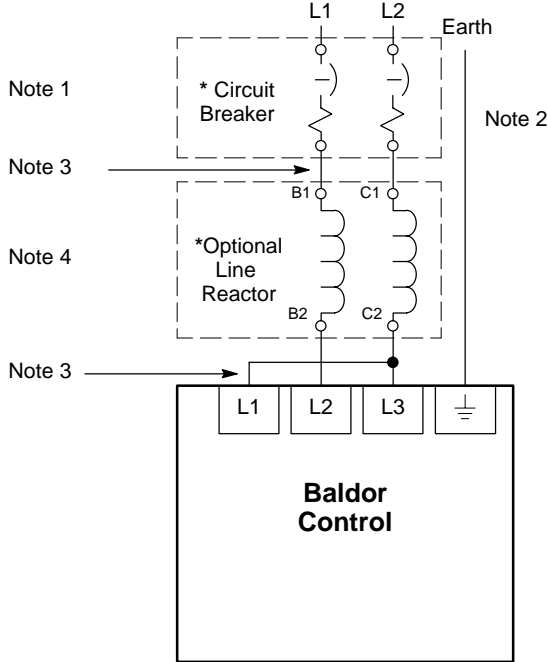
**Size F Single Phase Power Installation** (See Figure 3-15.)

**Figure 3-14 Jumper Configuration**

Place JP2 on the High Voltage Circuit Board across pins 1 and 2.



**Figure 3-15 Size F Single Phase 230/460VAC Power Connections**



\* Optional components not provided with control.

Notes:

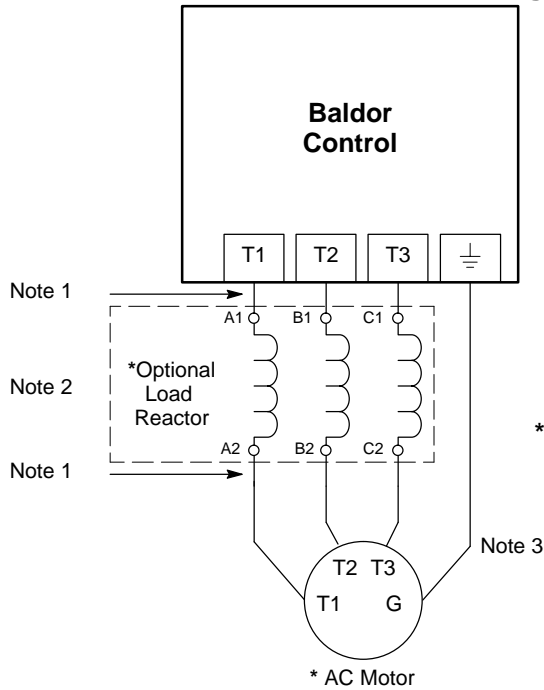
1. See "Protective Devices" described previously in this section.
2. Use same gauge wire for Earth ground as is used for L1, L2 and L3.
3. Metal conduit should be used. Connect conduits so the use of a Reactor or RC Device does not interrupt EMI/RFI shielding.
4. See Line/Load Reactors described previously in this section.

See Recommended Tightening Torques in Section 7.

## Motor Connections

Motor connections are shown in Figure 3-16.

**Figure 3-16 Motor Connections**



Notes:

1. Metal conduit should be used. Connect conduits so the use of Load Reactor or RC Device does not interrupt EMI/RFI shielding.
2. See Line/Load Reactors described previously in this section.
3. Use same gauge wire for Earth ground and motor leads (from the 3 phase wire size tables).
4. Motors are phase sensitive. If the motor leads are labeled 1, 2, 3 then lead 1 must be connected to T1 etc. If the motor leads are labeled U, V, W then lead U must be connected to T1 etc.
5. Connect the motor ground lead to the  $\perp$  of the control.

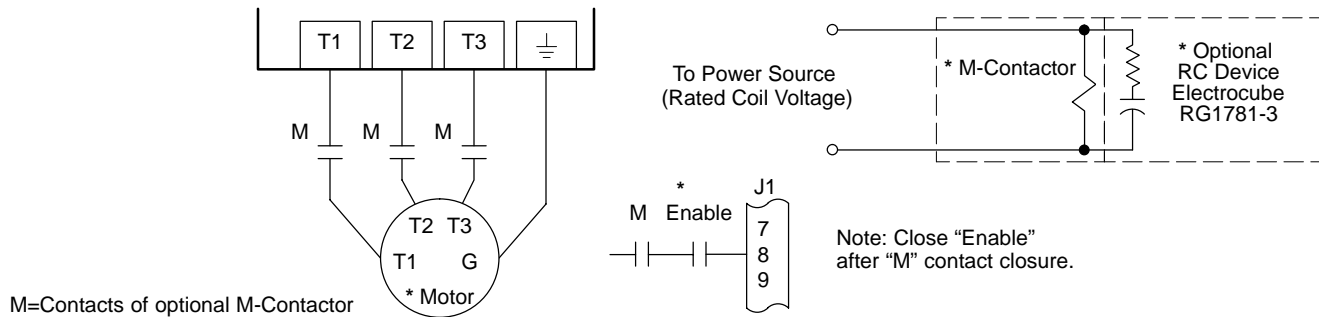
\* Optional components not provided with control.

See Recommended Tightening Torques in Section 7.

## M-Contactor

If required by local codes or for safety reasons, an M-Contactor (motor circuit contactor) may be installed. However, incorrect installation or failure of the M-contactor or wiring may damage the control. If an M-Contactor is installed, the control must be disabled for at least 20msec before the M-Contactor is opened or the control may be damaged. M-Contactor connections are shown in Figure 3-17.

**Figure 3-17 Optional M-Contactor Connections**



See Recommended Tightening Torques in Section 7.

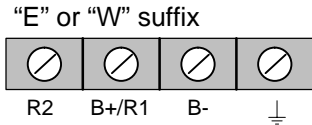
## Optional Dynamic Brake Hardware

Dynamic Brake (DB) Hardware must be installed on a flat, non-flammable, vertical surface for effective cooling and operation. Refer to MN701 (for RGA, RBA and RTA assemblies) or MN782 (for RUA assemblies) for additional information.

### Electrical Installation

Terminal connections for DB hardware is determined by the control model number suffix (E, EO, ER or MO). See Figure 3-18 for terminal identification. Refer to Tables 3-6 and 3-7 for wire size information.

**Figure 3-18 DB Terminal Identification**

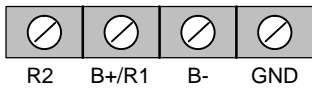


Note: Although not shown, metal conduit should be used to shield all power wires and motor leads.

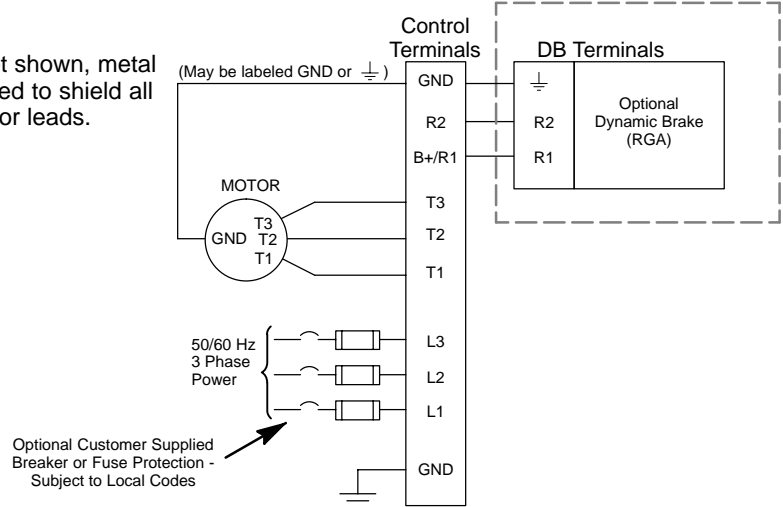
“EO” or “MO” suffix



“ER” suffix

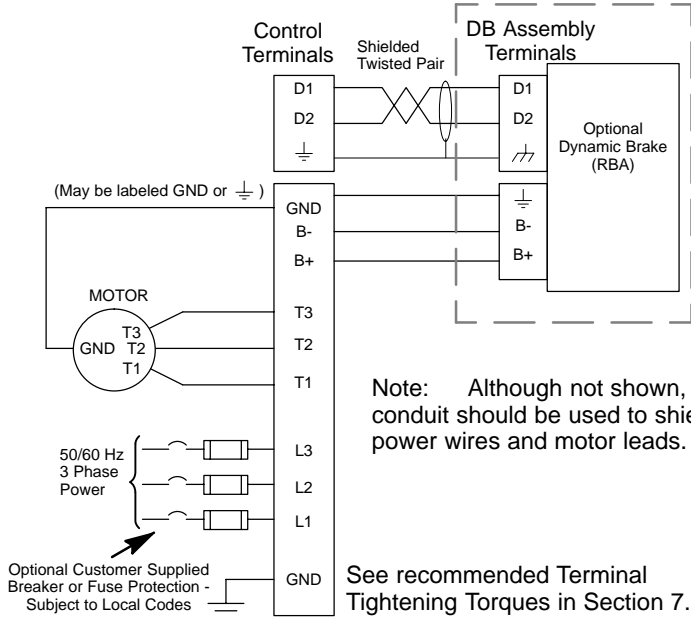


**Figure 3-19 Wiring for RGA Assembly (-E, -W, -ER)**



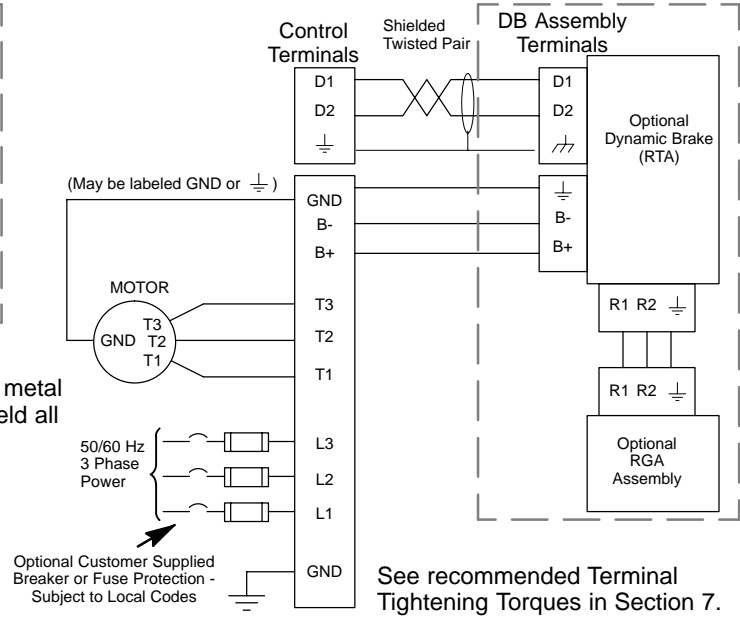
See recommended Terminal Tightening Torques in Section 7.

**Figure 3-20 Wiring for RBA Assembly (-EO, -MO)**



See recommended Terminal Tightening Torques in Section 7.

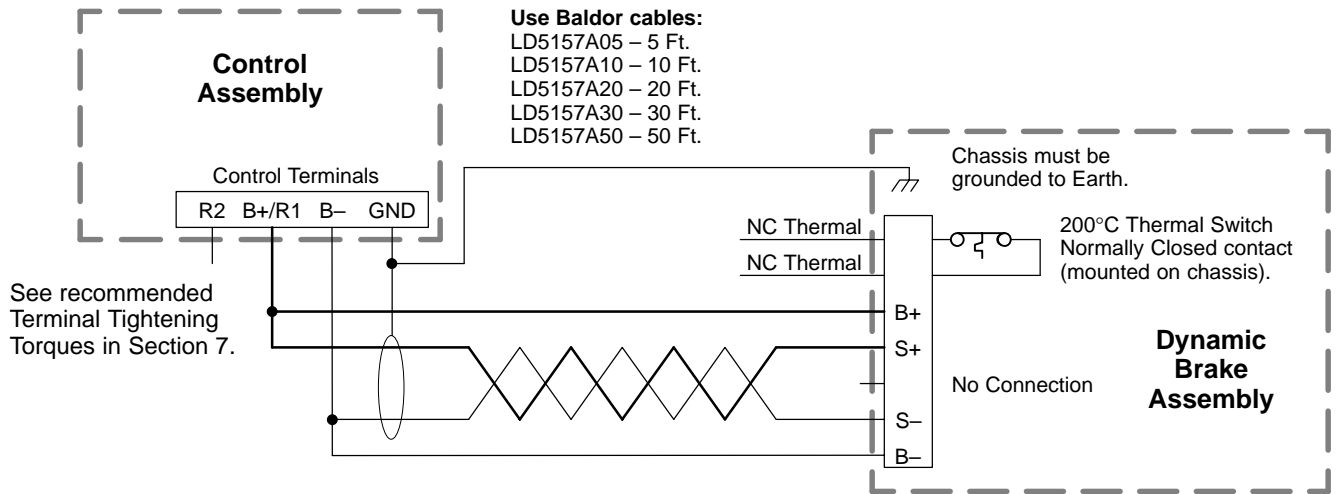
**Figure 3-21 Wiring for RTA Assembly (-EO, -MO)**



See recommended Terminal Tightening Torques in Section 7.

The RUA Dynamic Brake assembly is designed for controls that have built in dynamic brake hardware. Be sure to disconnect the internal resistor wires from control terminals. These factory installed wires must be removed and the wire ends insulated with electrical tape to prevent contact with other components. The braking capability may also need to be disabled in software. For Baldor controls, reduce the resistor ohms to the lowest value and increase the resistor watts to greatest value. Be sure to select the proper size kit based on the dissipation rating of the resistor(s) to handle the average watts of the overhauling or cyclic load.

**Figure 3-22 Wiring for RUA Assembly**



Note: Sense lines S+ and S- must be shielded, twisted pair wire. Terminate shields at control end only.

See recommended Terminal Tightening Torques and wire sizes in Table 3-6.

**Table 3-6 Terminal Torques & Wire Size for RUA Assemblies**

Control Rating VAC	Braking Option Watts Max.	B+ and B- Terminals					S+ and S- Terminals				
		Shielded Wire Size		AC Volt	Tightening Torque		Shielded Wire Size		AC Volt	Tightening Torque	
		AWG	mm <sup>2</sup>		Lb-in	Nm	AWG	mm <sup>2</sup>		Lb-in	Nm
230	746	16	1.31	300	9	1	20	0.51	300	9	1
230	1492	16	1.31	300	9	1	20	0.51	300	9	1
230	1865	16	1.31	300	9	1	20	0.51	300	9	1
230	2238	14	2.08	300	9	1	20	0.51	300	9	1
230	3730	14	2.08	300	9	1	20	0.51	300	9	1
230	5600	14	2.08	300	9	1	20	0.51	300	9	1
460	746	16	1.31	600	9	1	20	0.51	600	9	1
460	1492	16	1.31	600	9	1	20	0.51	600	9	1
460	1865	16	1.31	600	9	1	20	0.51	600	9	1
460	2238	16	1.31	600	9	1	20	0.51	600	9	1
460	3730	14	2.08	600	9	1	20	0.51	600	9	1
460	5600	14	2.08	600	9	1	20	0.51	600	9	1

**Table 3-7 Dynamic Brake Wire Size for RGA, RBA and RTA Assemblies**

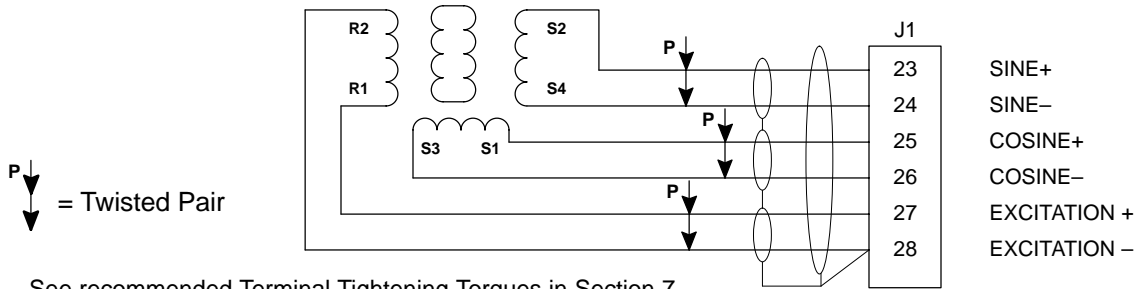
Control Voltage Rating VAC	Braking Option Watts Rating	B+ / B- and R1 / R2 / $\perp$			D1 / D2 / $\perp$		
		Terminals		Volt	Terminals		Volt
		Wire Size			Wire Size		
		AWG	mm <sup>2</sup>		AWG	mm <sup>2</sup>	
230	<2,000	16	1.31	600	20-22	0.5	600
230	2,100 – 5,000	14	2.08	600	20-22	0.5	600
230	5,100 – 10,000	10	6	600	20-22	0.5	600
230	>10,000	8	10	600	20-22	0.5	600
460	<4,000	16	1.31	600	20-22	0.5	600
460	4,100 – 10,000	14	2.08	600	20-22	0.5	600
460	10,100 – 20,000	10	6	600	20-22	0.5	600
460	>20,000	8	10	600	20-22	0.5	600

**Resolver Feedback**

The resolver connections are made at the J1 connector as shown in Figure 3-23. The resolver cable must be shielded twisted pair #22 AWG (0.34mm<sup>2</sup>) wire minimum. The cable must also have an overall shield and not exceed 150 feet (45m) in length. Maximum wire-to-wire or wire-to-shield capacitance is 50pf per foot (maximum of 7500pf for 150 ft). See electrical noise considerations in Section 5 of this manual.

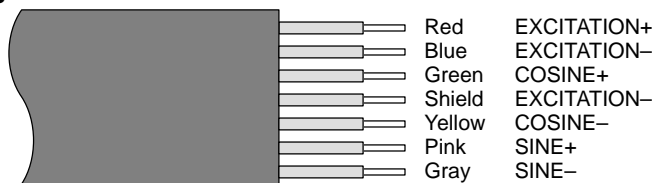
Resolver wiring must be separated from power wiring. Separate parallel runs of resolver and power cables by at least 3". Cross power wires at right angles only. Insulate or tape ungrounded end of shields to prevent contact with other conductors or ground.

**Figure 3-23 Resolver Cable Connections**



See recommended Terminal Tightening Torques in Section 7.

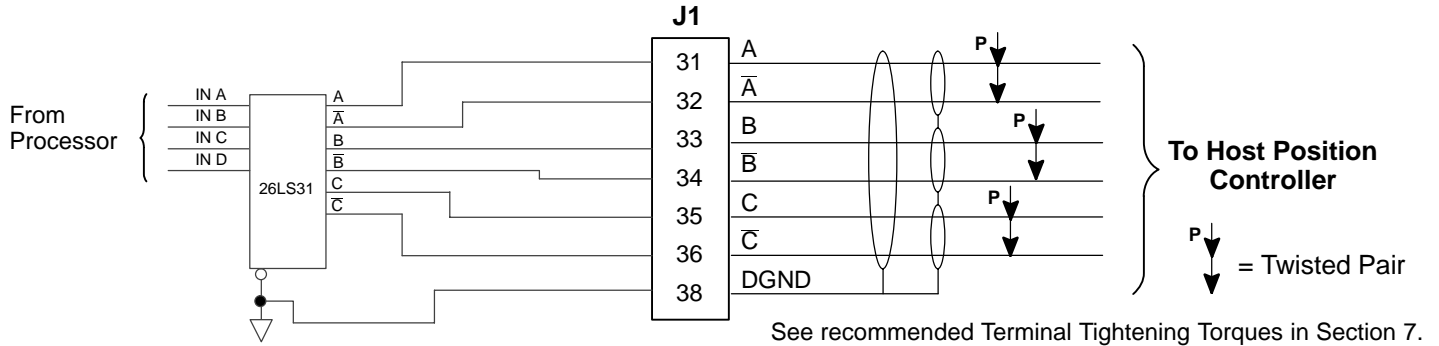
**Figure 3-24 Baldor Resolver Cable Lead Identification**



**Simulated Encoder Output** The control provides a simulated encoder output at connector J1 as shown in Figure 3-25. This output provides position information to the host controller. Use twisted pair wire with an overall shield.

This output simulates a 1024 ppr encoder with quadrature outputs. Counting in quadrature will provide 4096 ppr with one index marker (CHC) per revolution. It is recommended that this output only drive one circuit load. Driving multiple loads is not recommended (to avoid ground loops).

**Figure 3-25 Simulated Encoder Output**





---

**Home (Orient) Switch Input** To use the internally generated index pulse for homing, no external connections are required. However, to use an external index input a jumper must be moved and the external index signal must be connected to J1-29 and 30.

#### External Index Jumper

Refer to Figure 3-30. The resolver feedback module must be removed from the main control board to change the JP1 position. Use the following procedure.

1. Use a grounded wrist strap.
2. Firmly grasp the Resolver Feedback Module and remove it from its connectors on the main control board. Be careful not to bend the pins by twisting or lifting the module unevenly.
3. Place the jumper in the desired position, refer to Figure 3-30.
4. Insert the Resolver Feedback Module back into its connectors on the main control board. Be careful not to bend the pins by twisting or lifting the module unevenly. Be sure the module is fully seated (pushed into) the connectors.

#### Connections for External Index Signal

The Home or Orient function causes the motor shaft to rotate to a predefined home position. The homing function allows shaft rotation in the drive forward direction only. The home position is located when a machine mounted switch or “Index” pulse is activated (closed). Home is defined by a rising signal edge at terminal J1-29. The shaft will continue to rotate only in a “Drive Forward” direction for a user defined offset value. The offset is programmed in the Level 2 Miscellaneous Homing Offset parameter. The speed at which the motor will “Home” or orient is set with the Level 2 Miscellaneous Homing Speed parameter.

A machine mounted switch may be used to define the Home position or “index” channel. A differential line driver output from a solid state switch is preferred for best noise immunity. Connect this differential output to terminals J1-29 and J1-30.

A single ended solid-state switch or limit switch should be wired as shown in Figure 3-26. Regardless of the type of switch used, clean rising and falling edges at J1-29 are required for accurate positioning.

Note: Control requires dynamic brake hardware for Orient (Homing) function to work. Control will trip without dynamic brake hardware installed. Size A and B controls (“-E” suffix) are shipped with factory installed dynamic brake hardware.

**Figure 3-26 Typical Home or Orient Switch Connections**



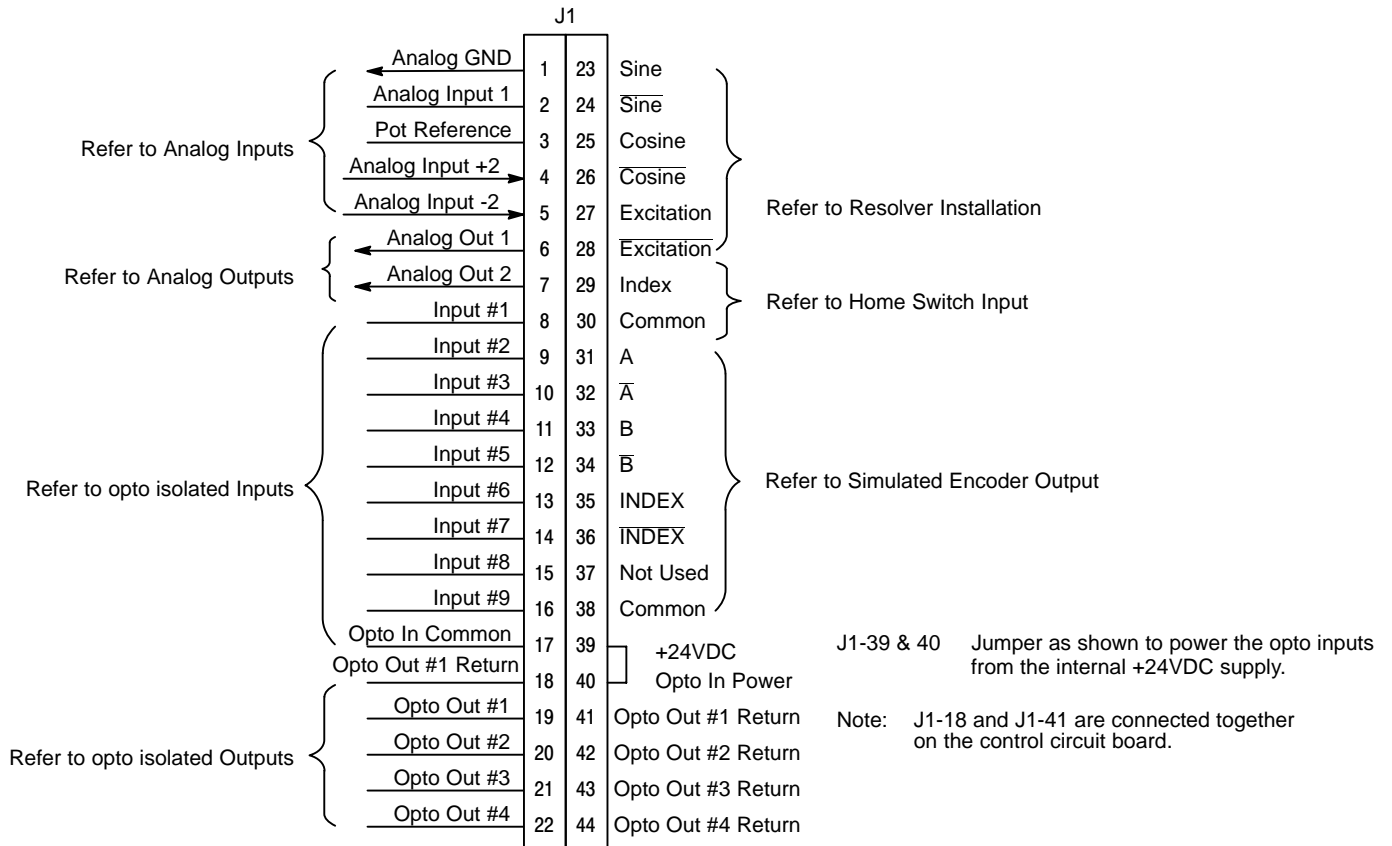
## Operating Modes

Ten operating modes are available. These modes define the basic motor control setup and the operation of the input and output terminals. After the circuit connections are completed, the operating mode is selected by programming the Operating Mode parameter in the Level 1 Input Programming Block. Operating modes include:

- Keypad
- Standard Run, 3 Wire
- 15 Speed, 2 Wire
- 3 SPD ANA 2 Wire
- 3 SPD ANA 3 Wire
- Bipolar Speed or Torque
- Process Control
- Serial
- Electronic Pot 2 Wire
- Electronic Pot 3 Wire

Each mode requires connections to the J1 terminal strip (except the keypad mode, all connections are optional). The J1 terminal strip is shown in Figure 3-27. The connection of each input or output signal is described in the following pages.

**Figure 3-27 Control Signal Connections**

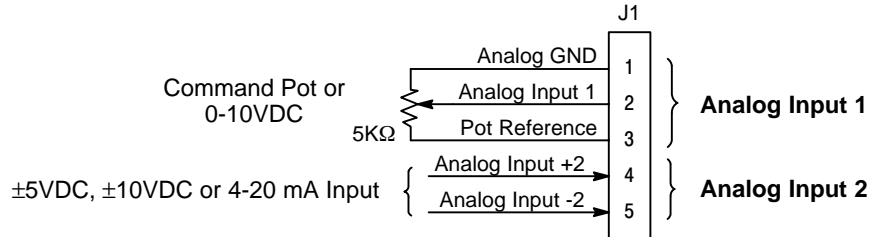


See recommended terminal tightening torques in Section 7.

## Analog Inputs

Two analog inputs are available: analog input #1 (J1-1 and J1-2) and analog input #2 (J1-4 and J1-5) as shown in Figure 3-28. Either analog input may be selected in the Level 1 INPUT block, Command Select parameter value. Analog input #1 is selected if the parameter value is "Potentiometer". Analog input #2 is selected if the parameter value is "+/-10Volts, +/-5 Volts or 4-20mA". Figure 3-29 shows the equivalent circuits of the Analog Inputs.

**Figure 3-28 Analog Inputs**



See recommended terminal tightening torques in Section 7.

### Analog Input #1 (Single Ended)

When using a potentiometer as the speed command, process feedback or setpoint source, the Level 1 Input block COMMAND SELECT parameter must be set to "POTENTIOMETER".

Note: A potentiometer value of 5kΩ to 10kΩ, 0.5 watt may be used.

#### Parameter Selection

The single ended analog input #1 can be used in one of three ways:

1. Speed or Torque command (Level 1 Input block, Command Select=Potentiometer).
2. Process Feedback (Level 2 Process Control block, Process Feedback=Potentiometer).
3. Setpoint Source (Level 2 Process Control block, Setpoint Source=Potentiometer).

When using Analog Input #1, the respective parameter must be set to "POTENTIOMETER".

### Analog Input #2 (Differential)

Analog input #2 accepts a differential command ±5VDC, ±10VDC or 4-20 mA.

If pin J1-4 is positive with respect to pin 5, the motor will rotate in the forward direction.

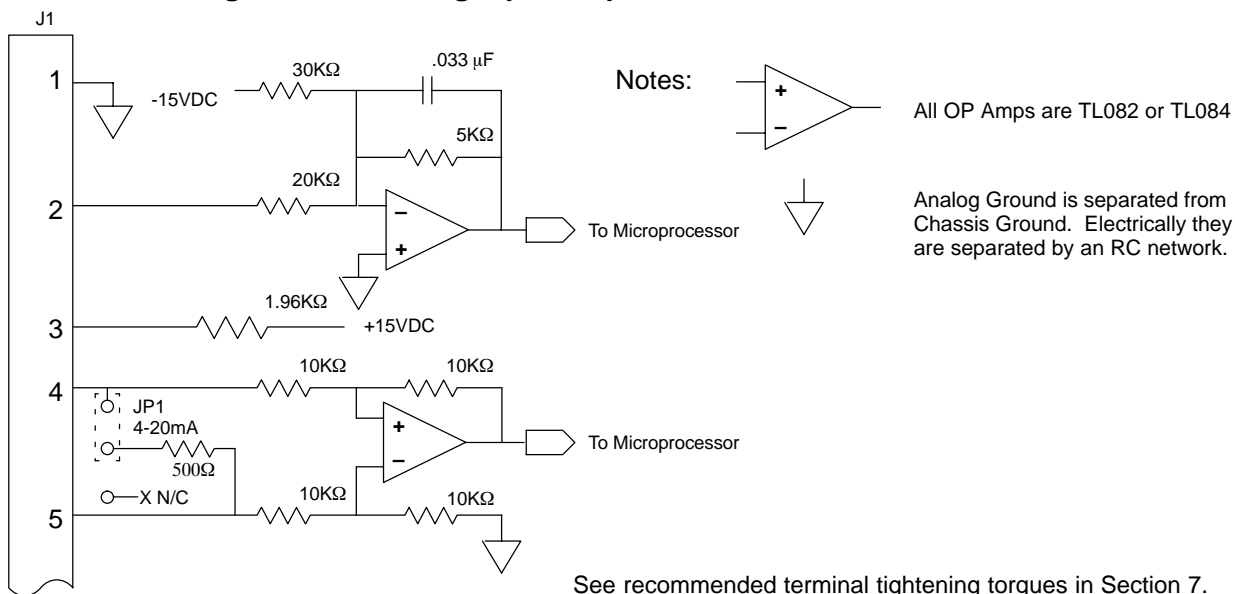
If pin J1-4 is negative with respect to pin 5, the motor will rotate in the reverse direction.

JP1 must be set for voltage or current operation as required. Analog Input #2 can be connected for single ended operation by grounding either of the inputs, provided the common mode voltage range is not exceeded.

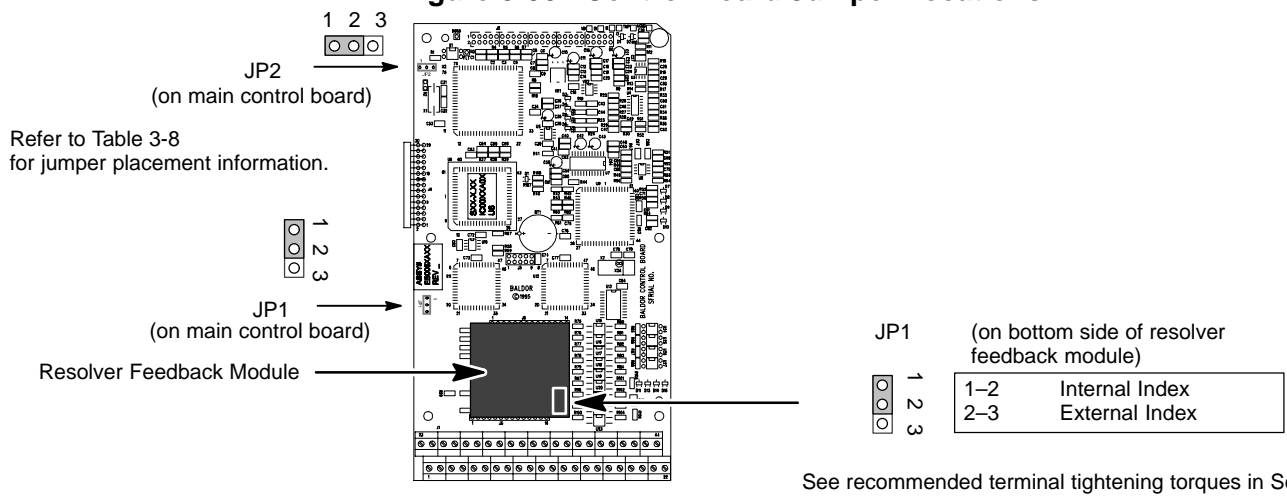
Note: The common mode voltage can be measured with a voltmeter. Apply the maximum command voltage to analog input 2 (J1-4, 5). Measure the AC and DC voltage across J1-1 to J1-4. Add the AC and DC readings together. Measure the AC and DC voltage from J1-1 to J1-5. Add the AC and DC readings together.

If either of these measurement totals exceeds a total of ±15 volts, then the common mode voltage range has been exceeded. To correct this condition, either change the command source or isolate the command signal with a signal isolator.

**Figure 3-29 Analog Inputs Equivalent Circuits**



**Figure 3-30 Control Board Jumper Locations**



**Table 3-8 Control Board Jumper**

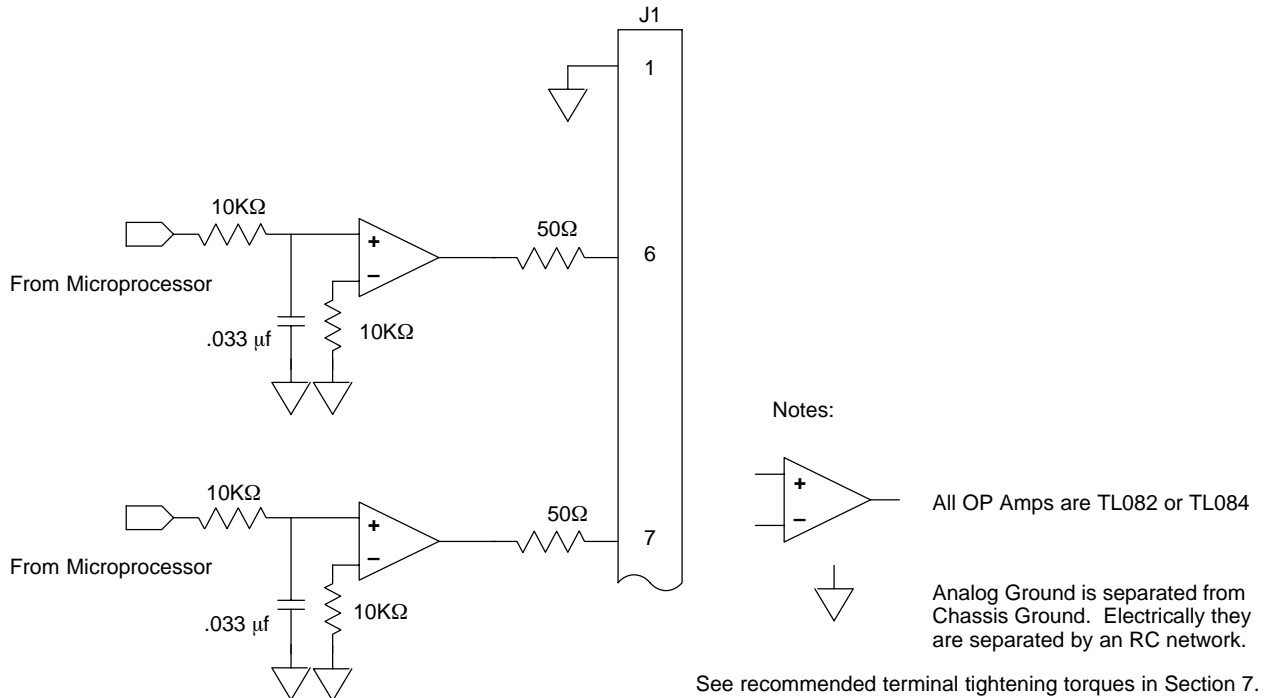
Jumper	Jumper Position	Description of Jumper Position Setting
JP1	1-2	Voltage Speed Command Signal. (Factory Setting)
	2-3	4-20mA Speed Command input at Analog #2
JP2	1-2	Factory Setting
	2-3	Not used.

## Analog Outputs

Two programmable analog outputs are provided on J1-6 and J1-7. See Figure 3-31. These outputs are scaled 0 - 5 VDC (1mA maximum output current) and can be used to provide real-time status of various control conditions. The output conditions are defined in Section 4 of this manual.

The return for these outputs is J1-1 analog ground. Each output is programmed in the Level 1 Output block.

**Figure 3-31 Analog Outputs Equivalent Circuits**



## Serial Operating Mode

The Serial operating mode requires one of the optional Serial Interface expansion boards (RS232, RS422 or RS485). Installation and operation information for these serial expansion boards is provided in Serial Communications expansion board manual MN1310. This manual is shipped with the serial expansion boards.

## Keypad Operating Mode

The Keypad operating mode allows the control to be operated from the keypad. This mode requires no connections to J1. However, the Enable, Stop and External Trip inputs may optionally be used. All other opto inputs remain inactive. The analog outputs and opto-outputs remain active at all times.

### Parameter Selection

For operation in Keypad mode, set the Level 1 Input block, Operating Mode parameter to Keypad. The STOP key can operate in two ways:

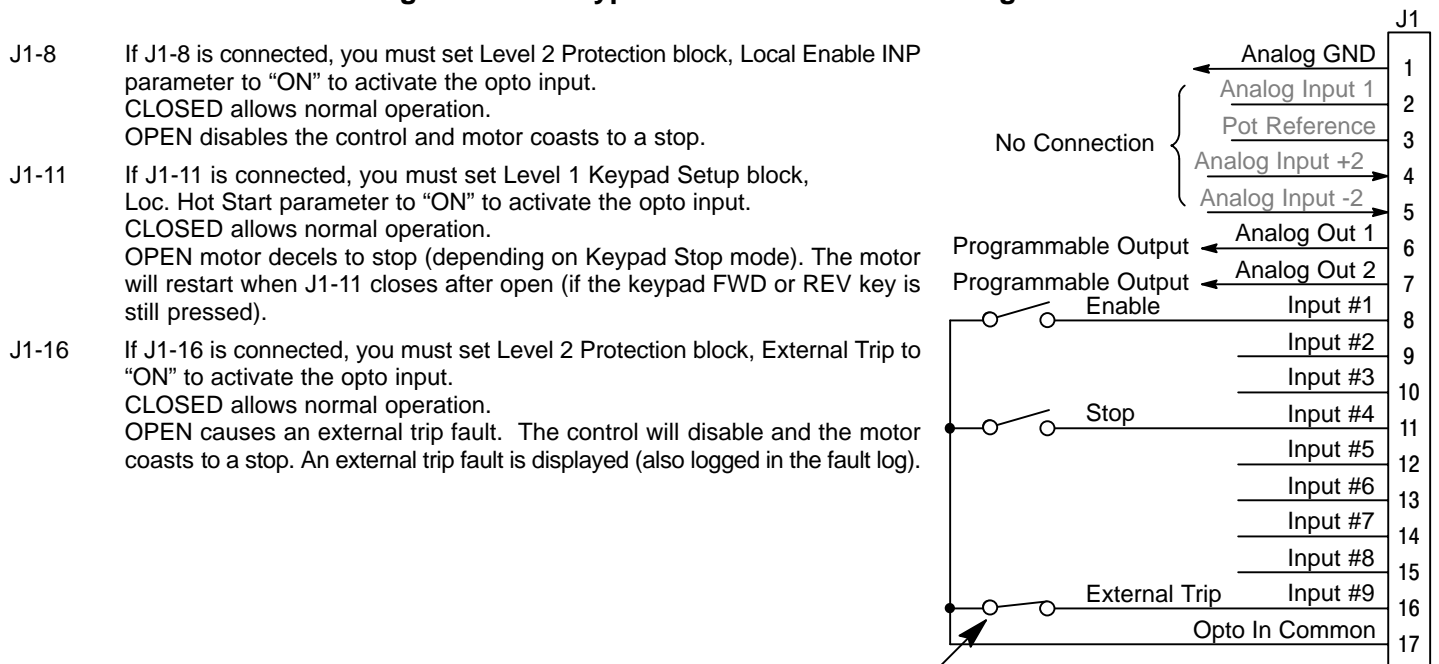
- Press STOP key one time to brake or coast to stop.
- Press STOP key two times to disable control.

To use the Enable input, J1-8 must be connected and the Local Enable INP parameter in the Level 2 Protection block must be set to ON. The Enable line is normally closed. When opened, the motor will COAST to a stop. When the enable line is again closed, the motor will not start until a new direction command is received from the keypad.

To use the Stop input, J1-11 must be connected and the Level 1 Keypad Setup block, LOC. Hot Start parameter must be set to ON. The Stop line is normally closed. When opened, the motor will COAST or REGEN to a stop depending upon the setting of Level 1 Keypad Setup block Keypad Stop Mode parameter value. Closing the input will immediately start the motor.

The External Trip input causes a fault condition during a motor over temperature condition (when normally closed input opens). The External Trip input (J1-16) must be connected and the External Trip parameter in the Level 2 Protection block must be set to "ON". When J1-16 is opened, an external trip fault occurs. The control will disable and the motor coasts to a stop. An external trip fault is displayed on the keypad display (also logged into the fault log).

**Figure 3-32 Keypad Control Connection Diagram**



Refer to Figure 3-41.

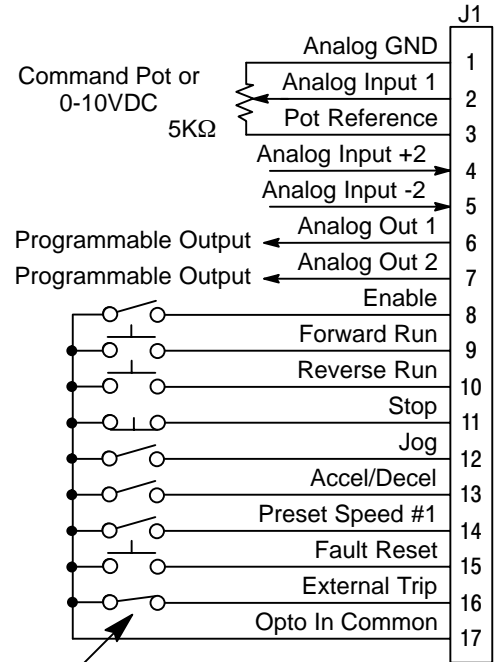
See recommended terminal tightening torques in Section 7.

## Standard Run 3 Wire Operating Mode

In Standard Run mode, the control is operated by the opto isolated inputs at J1-8 through J1-16 and the analog command input. The opto inputs can be switches as shown in Figure 3-33 or logic signals from another device.

**Figure 3-33 Standard Run 3-Wire Connection Diagram**

J1-8	CLOSED allows normal operation. OPEN disables the control and motor coasts to a stop.
J1-9	MOMENTARY CLOSED starts motor operation in the Forward direction. In JOG mode (J1-12 CLOSED), continuous CLOSED jogs motor in the Forward direction.
J1-10	MOMENTARY CLOSED starts motor operation in the Reverse direction. In JOG mode (J1-12 CLOSED), CONTINUOUS closed JOGS motor in the Reverse direction.
J1-11	MOMENTARY OPEN motor decels to stop (depending on Keypad Stop mode).
J1-12	CLOSED places control in JOG mode, Forward and Reverse run are used to jog the motor.
J1-13	CLOSED selects ACC / DEC / S-CURVE group 2. OPEN selects ACC / DEC / S-CURVE group 1.
J1-14	CLOSED selects preset speed #1, (J1-12, will override this preset speed). OPEN allows speed command from Analog input #1 or #2.
J1-15	CLOSED to reset fault condition. OPEN to run.
J1-16	If J1-16 is connected, you must set Level 2 Protection block, External Trip to "ON" to activate the opto input. CLOSED allows normal operation. OPEN causes an external trip fault. The control will disable and the motor coasts to a stop. An external trip fault is displayed (also logged in the fault log).



Refer to Figure 3-41.

See recommended terminal tightening torques in Section 7.

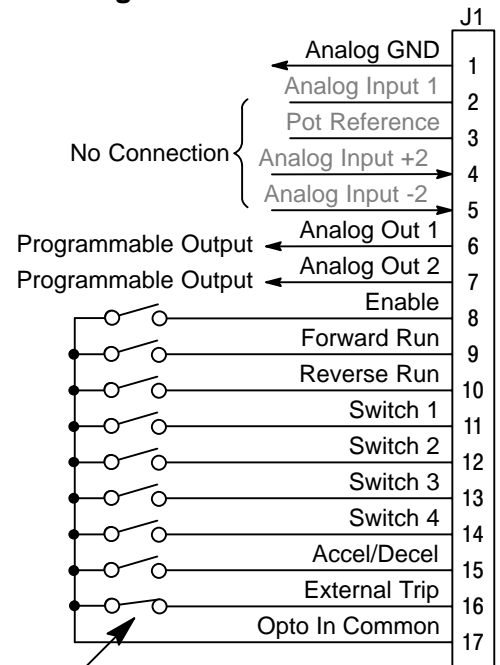
## 15 Speed 2-Wire Operating Mode

Operation in the 15 Speed 2-Wire mode is controlled by the opto isolated inputs at J1-8 through J1-16. The opto inputs can be switches as shown in Figure 3-34 or logic signals from another device.

Switched inputs at J1-11 through J1-14 allow selection of 15 preset speeds and provide Fault Reset as defined in Table 3-9.

**Figure 3-34 15 Speed 2-Wire Control Connection Diagram**

- J1-8      CLOSED allows normal operation.  
OPEN disables the control and motor coasts to a stop.
- J1-9      CLOSED operates the motor in the Forward direction (with J1-10 open).  
OPEN motor decels to stop (depending on Keypad Stop mode).
- J1-10     CLOSED operates motor in the Reverse direction (with J1-9 open).  
OPEN motor decels to stop (depending on Keypad Stop mode).
- J1-11-14 Selects programmed preset speeds as defined in Table 3-9.
- J1-15     CLOSED selects ACC / DEC / S-CURVE group 2.  
OPEN selects ACC / DEC / S-CURVE group 1.
- J1-16     If J1-16 is connected, you must set Level 2 Protection block, External Trip to "ON" to activate the opto input.  
CLOSED allows normal operation.  
OPEN causes an external trip fault. The control will disable and the motor coasts to a stop. An external trip fault is displayed (also logged in the fault log).



See recommended terminal tightening torques in Section 7.

**Table 3-9 Switch Truth Table for 15 Speed, 2 Wire Control Mode**

Function	J1-11	J1-12	J1-13	J1-14
Preset 1	Open	Open	Open	Open
Preset 2	Closed	Open	Open	Open
Preset 3	Open	Closed	Open	Open
Preset 4	Closed	Closed	Open	Open
Preset 5	Open	Open	Closed	Open
Preset 6	Closed	Open	Closed	Open
Preset 7	Open	Closed	Closed	Open
Preset 8	Closed	Closed	Closed	Open
Preset 9	Open	Open	Open	Closed
Preset 10	Closed	Open	Open	Closed
Preset 11	Open	Closed	Open	Closed
Preset 12	Closed	Closed	Open	Closed
Preset 13	Open	Open	Closed	Closed
Preset 14	Closed	Open	Closed	Closed
Preset 15	Open	Closed	Closed	Closed
Fault Reset	Closed	Closed	Closed	Closed



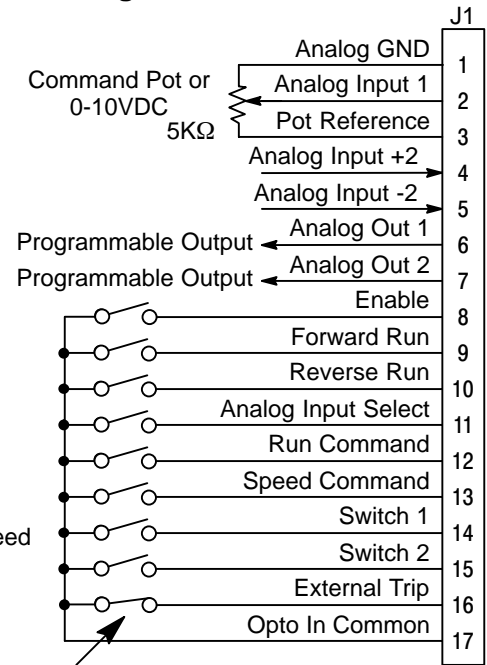
### 3 Speed Analog 2 Wire Operating Mode

Allows selection of 3 preset speeds with 2 wire inputs. The opto inputs can be switches as shown in Figure 3-35 or logic signals from another device.

The values of the preset speeds are set in the Level 1 Preset Speeds block, Preset Speed #1, Preset Speed #2 and Preset Speed #3.

**Figure 3-35 3 SPD ANA 2 Wire Control Connection Diagram**

- J1-8 CLOSED allows normal operation.  
OPEN disables the control and the motor coasts to a stop.
- J1-9 CLOSED operates the motor in the Forward direction (with J1-10 open).  
OPEN motor decels to stop (depending on Keypad Stop mode).
- J1-10 CLOSED operates the motor in the Reverse direction (with J1-9 open).  
OPEN motor decels to stop (depending on Keypad Stop mode).
- Note: Closing both J1-9 and J1-10 at the same time will reset a fault condition.
- J1-11 CLOSED selects Analog Input #1.  
OPEN selects Level 1 Input block, Command Select parameter.
- Note: If Command Select (Level 1 Input block) is set to Potentiometer, then Analog Input #1 is always selected regardless of this switch position.
- J1-12 CLOSED selects STOP/START and Reset commands from terminal strip.  
OPEN selects STOP/START and Reset commands from Keypad.
- J1-13 CLOSED selects Level 1 Input block, Command Select parameter.  
OPEN selects speed commanded from Keypad.
- Note: When changing from Terminal Strip to Keypad (J1-12 or J1-13) the motor speed and direction will remain the same after the change.
- J1-14 Selects preset speeds as defined in the Speed Select Table (Table 3-10).
- J1-15 Selects preset speeds as defined in the Speed Select Table (Table 3-10).
- J1-16 If J1-16 is connected, you must set Level 2 Protection block, External Trip to "ON"  
to activate the opto input.  
CLOSED allows normal operation.  
OPEN causes an external trip fault. The control will disable and the motor coasts to a stop. An external trip fault is displayed (also logged in the fault log).



Refer to Figure 3-41.

See recommended terminal tightening torques in Section 7.

**Table 3-10 Speed Select Table**

J1-14	J1-15	Command
OPEN	OPEN	Analog Input (Command Select)
CLOSED	OPEN	Preset #1
OPEN	CLOSED	Preset #2
CLOSED	CLOSED	Preset #3

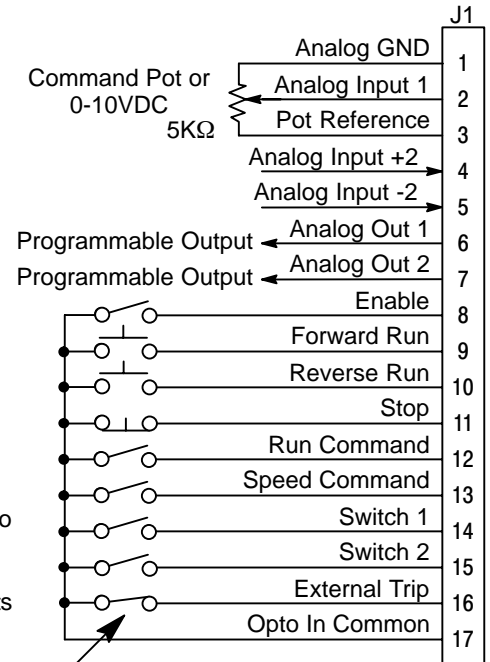
### 3 Speed Analog 3 Wire Operating Mode

Allows selection of 3 preset speeds with 3 wire inputs. The opto inputs can be switches as shown in Figure 3-36 or logic signals from another device.

The values of the preset speeds are set in the Level 1 Preset Speeds block, Preset Speed #1, Preset Speed #2 and Preset Speed #3.

**Figure 3-36 3 SPD ANA 3 Wire Control Connection Diagram**

- J1-8      CLOSED allows normal operation.  
            OPEN disables the control and the motor coasts to a stop.
- J1-9      MOMENTARY CLOSED starts motor operation in the Forward direction.
- J1-10     MOMENTARY CLOSED starts motor operation in the Reverse direction.  
            Note: Closing both J1-9 and J1-10 at the same time will reset a fault condition.
- J1-11     Momentary OPEN motor decels to stop (depending on Keypad Stop mode).
- J1-12     CLOSED selects STOP/START and Reset commands from terminal strip.  
            OPEN selects STOP/START and Reset commands from Keypad.
- J1-13     CLOSED selects Level 1 Input block, Command Select parameter.  
            OPEN selects speed commanded from Keypad.  
            Note: When changing from Terminal Strip to Keypad (J1-12 or J1-13) the motor speed and direction will remain the same after the change.
- J1-14     Selects preset speeds as defined in the Speed Select Table (Table 3-11).
- J1-15     Selects preset speeds as defined in the Speed Select Table (Table 3-11).
- J1-16     If J1-16 is connected, you must set Level 2 Protection block, External Trip to "ON" to activate the opto input.  
            CLOSED allows normal operation.  
            OPEN causes an external trip fault. The control will disable and the motor coasts to a stop. An external trip fault is displayed (also logged in the fault log).



Refer to Figure 3-41.

See recommended terminal tightening torques in Section 7.

**Table 3-11 Speed Select Table**

J1-14	J1-15	Command
OPEN	OPEN	Analog Input (Command Select)
CLOSED	OPEN	Preset #1
OPEN	CLOSED	Preset #2
CLOSED	CLOSED	Preset #3

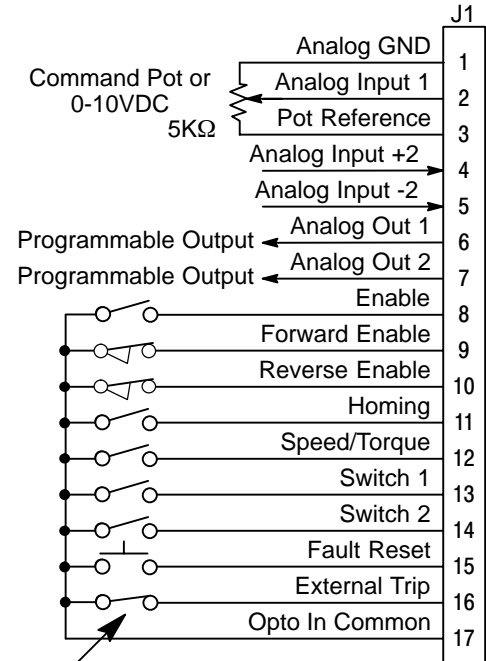
## Bipolar Speed or Torque Operating Mode

Provides bipolar speed or torque control. Also, you may store up to four (4) complete sets of operating parameters. This is important if you wish to store and use different acceleration rates, speed commands, jog speeds or to store tuning parameter values for different motors etc. The opto inputs can be switches as shown in Figure 3-37 or logic signals from another device.

Note: In Bipolar mode, the pot input can only be used in the forward direction.  
To operate in either direction, Analog Input 2 must be used.

**Figure 3-37 Bipolar Speed or Torque Connection Diagram**

- J1-8 CLOSED allows normal operation.  
OPEN disables the control & motor coasts to a stop.
- J1-9 CLOSED to enable operation in the Forward direction.  
OPEN TO DISABLE Forward operation (drive will brake to a stop if a Forward command is still present).  
Reverse operation is still possible if J1-10 is closed.
- J1-10 CLOSED to enable operation in the Reverse direction.  
OPEN to disable Reverse operation (drive will brake to a stop if a Reverse command is still present).  
Forward operation is still possible if J1-9 is closed.
- Note: If J1-9 and J1-10 are both opened, the drive will brake to a stop.
- J1-11 CLOSED causes the motor to rotate in the forward direction until the load reaches a marker or external switch location.  
OPEN allows normal operation.
- J1-12 CLOSED puts the control in torque (current) command mode.  
OPEN puts the control in speed (velocity) command mode.
- Note: If a stop command is issued while in the torque (current) mode, the control will stop but will not maintain position (zero current). This is different than zero speed operation for the velocity mode.
- J1-13 & 14 Select from four parameter tables as defined in Table 3-12.
- J1-15 Momentary CLOSED to reset fault condition.  
OPEN allows normal operation.
- J1-16 If J1-16 is connected, you must set Level 2 Protection block, External Trip to "ON" to activate the opto input.  
CLOSED allows normal operation.  
OPEN causes an external trip fault. The control will disable and the motor coasts to a stop. An external trip fault is displayed (also logged in the fault log).



Refer to Figure 3-41.

See recommended terminal tightening torques in Section 7.

**Table 3-12 Bipolar Mode Table Select Truth Table**

Function	J1-13	J1-14
Parameter Table #0	Open	Open
Parameter Table #1	Closed	Open
Parameter Table #2	Open	Closed
Parameter Table #3	Closed	Closed

Note: See multiple parameter sets.

---

## Multiple Parameter Sets

The following procedure allows you to program up to four complete sets of parameter values and to use these multiple parameter sets. When programming each parameter set, use the ENTER key to accept and automatically save parameter values.

Note: The control can be programmed in the REMOTE mode with the drive enabled. The control must be disabled to change the operating mode parameter and the operating mode can not be stored in a parameter table.

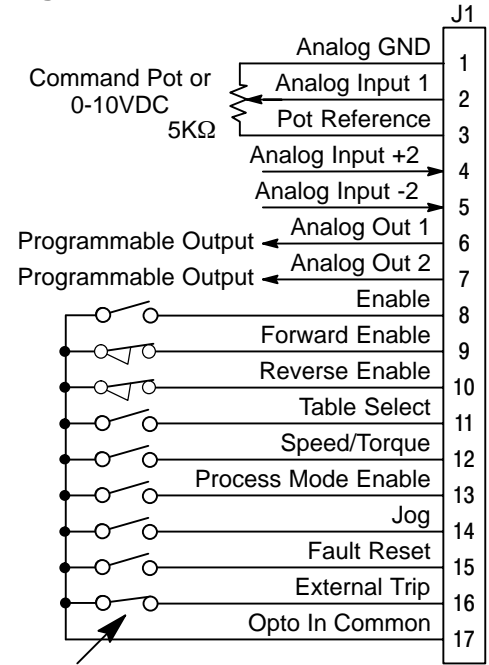
Note: Preset speed does not apply to table select.

1. If this is a new installation, do this procedure after the Pre-Operation Checklist and Power-Up Procedures at the end of this section.
2. Set the Level 1 INPUT block, Operating Mode parameter value to BIPOLAR in each of the parameter sets.
3. Set switches J1-13 and J1-14 to Parameter Table #0 (both switches open). Be sure switches J1-9 and J1-10 are OPEN, J1-8 is CLOSED. Enter all parameter values, and autotune as instructed in Section 3 of this manual. This creates and saves the first parameter set which is numbered Table#0.
4. Set switches J1-13 and J1-14 to Parameter Table #1. Be sure switches J1-9 and J1-10 are OPEN, J1-8 is CLOSED. Enter all parameter values, and autotune as instructed in Section 3 of this manual. This creates and saves the second parameter set which is numbered Table#1.
5. Set switches J1-13 and J1-14 to Parameter Table #2. Be sure switches J1-9 and J1-10 are OPEN, J1-8 is CLOSED. Enter all parameter values, and autotune as instructed in Section 3 of this manual. This creates and saves the third parameter set which is numbered Table#2.
6. Set switches J1-13 and J1-14 to Parameter Table #3. Be sure switches J1-9 and J1-10 are OPEN, J1-8 is CLOSED. Enter all parameter values, and autotune as instructed in Section 3 of this manual. This creates and saves the final parameter set which is numbered Table#3.
7. Remember that to change the value of a parameter in one of the parameter tables, you must first select the table using the switches. You cannot change a value in a table until you have first selected that table.

## Process Operating Mode

**Figure 3-38 Process Mode Connection Diagram**

- J1-8 CLOSED allows normal operation.  
OPEN disables the control & motor coasts to a stop.
- J1-9 CLOSED to enable operation in the Forward direction.  
OPEN TO DISABLE Forward operation (drive will brake to a stop if a Forward command is still present). Reverse operation is still possible if J1-10 is closed.
- J1-10 CLOSED to enable operation in the Reverse direction.  
OPEN to disable Reverse operation (drive will brake to a stop if a Reverse command is still present). Forward operation is still possible if J1-9 is closed.
- Note: If J1-9 and J1-10 are both opened, the drive will brake to a stop.
- J1-11 CLOSED = TABLE 1, OPEN = TABLE 0. (See multiple parameter sets.)
- J1-12 CLOSED, the control is in torque (current) command mode.  
OPEN, the control is in speed (velocity) command mode.
- Note: If a stop command is issued while in the torque (current) mode, the control will stop but will not maintain position (zero current). This is different than zero speed operation for the velocity mode.
- J1-13 CLOSED to enable the Process Mode.
- J1-14 CLOSED places control in JOG mode. The control will only JOG in the forward direction.
- J1-15 CLOSED to reset a fault condition.  
OPEN to run.
- J1-16 If J1-16 is connected, you must set Level 2 Protection block, External Trip to "ON" to activate the opto input.  
CLOSED allows normal operation.  
OPEN causes an external trip fault. The control will disable and the motor coasts to a stop. An external trip fault is displayed (also logged in the fault log).



Refer to Figure 3-41.

See recommended terminal tightening torques in Section 7.

**Table 3-13 Process Mode Input Signal Compatibility**

Setpoint or Feedforward	Feedback						
	J1-1 & 2	J1-4 & 5	5V EXB <sup>①</sup>	10V EXB <sup>①</sup>	4-20mA EXB <sup>①</sup>	3-15 PSI EXB <sup>②</sup>	DC Tach EXB <sup>③</sup>
J1-1 & 2	■						
J1-4 & 5		■					
5V EXB <sup>①</sup>			■	■	■	■	
10V EXB <sup>①</sup>			■	■	■	■	
4-20mA EXB <sup>①</sup>			■	■	■	■	
3-15 PSI EXB <sup>②</sup>			■	■	■	■	
DC Tach EXB <sup>③</sup>							■
EXB PULSE FOL <sup>④</sup> <sup>⑤</sup>							■
Serial <sup>⑤</sup> <sup>⑥</sup>			■	■	■	■	

- ① Requires expansion board EXB007A01 (High Resolution Analog I/O EXB).
- ② Requires expansion board EXB004A01 (4 Output Relays/3-15 PSI Pneumatic Interface EXB).
- ③ Requires expansion board EXB006A01 (DC Tachometer Interface EXB).
- ④ Requires expansion board EXB005A01 (Master Pulse Reference/Isolated Pulse Follower EXB).
- ⑤ Used for Feedforward only. Must not be used for Setpoint Source or Feedback.
- ⑥ Requires expansion board EXB001A01 (RS232 Serial Communication EXB). or Requires expansion board EXB002A01 (RS422/RS485 High Speed Serial Communication EXB).

■ Conflicting inputs. Do not use same input signal multiple times.

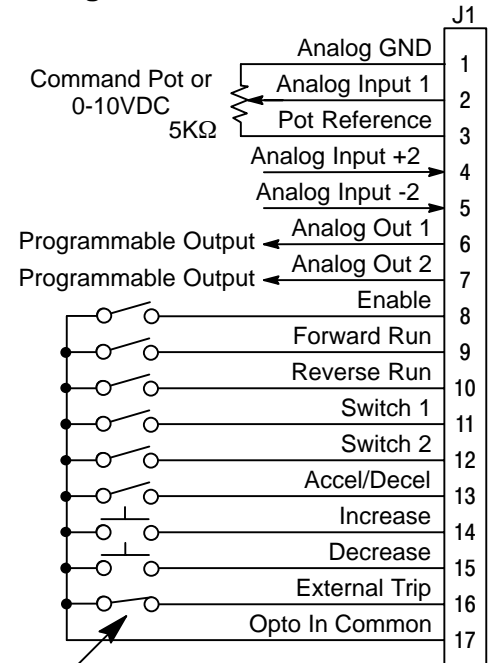
▨ Conflicting level 1 or 2 expansion boards. Do not use!

## Electronic Pot 2 Wire Operating Mode

Provides speed Increase and Decrease inputs to allow EPOT operation with 2 wire inputs. The opto inputs can be switches as shown in Figure 3-39 or logic signals from another device. The values of the preset speeds are set in the Level 1 Preset Speeds block, Preset Speed #1 or Preset Speed #2.

**Figure 3-39 EPOT, 2 Wire Control Connection Diagram**

- J1-8 CLOSED allows normal operation.  
OPEN disables the control and motor coasts to a stop.
- J1-9 CLOSED starts motor operation in the Forward direction.  
OPEN motor decels to stop (depending on Keypad Stop mode).
- J1-10 CLOSED starts motor operation in the Reverse direction.  
OPEN motor decels to stop (depending on Keypad Stop mode).
- Note: Closing both J1-9 and J1-10 at the same time will reset a fault condition.
- J1-11 Selects preset speeds as defined in the Speed Select Table (Table 3-14).
- J1-12 Selects preset speeds as defined in the Speed Select Table (Table 3-14).
- J1-13 CLOSED selects ACC / DEC / S-CURVE group 2.  
OPEN selects ACC / DEC / S-CURVE group 1.
- J1-14 Momentary CLOSED increases motor speed while contact is closed.
- J1-15 Momentary CLOSED decreases motor speed while contact is closed.
- J1-16 If J1-16 is connected, you must set Level 2 Protection block, External Trip to "ON" to activate the opto input.  
CLOSED allows normal operation.  
OPEN causes an external trip fault. The control will disable and the motor coasts to a stop. An external trip fault is displayed (also logged in the fault log).



Refer to Figure 3-41.

See recommended terminal tightening torques in Section 7.

**Table 3-14 Speed Select Table**

J1-11	J1-12	Function
OPEN	OPEN	Electronic Pot
CLOSED	OPEN	Command Select *
OPEN	CLOSED	Preset #1
CLOSED	CLOSED	Preset #2

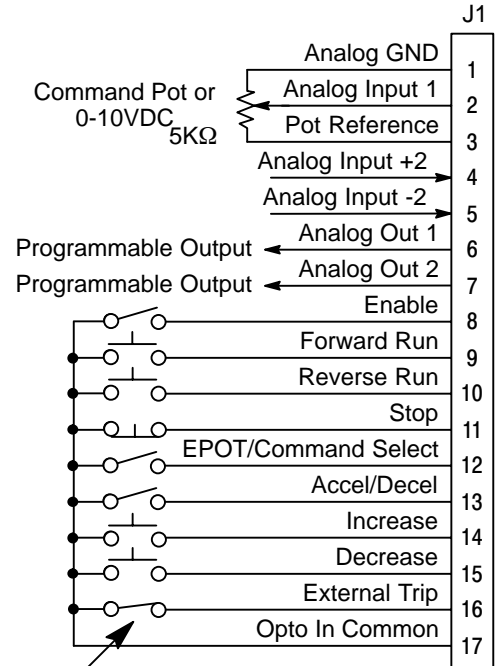
\* Command Select refers to the Level 1 Command Select parameter.

## Electronic Pot 3 Wire Control Mode

Provides speed Increase and Decrease inputs to allow EPOT operation with 3 wire inputs. The opto inputs can be switches as shown in Figure 3-40 or logic signals from another device.

**Figure 3-40 EPOT, 3 Wire Control Connection Diagram**

- J1-8 CLOSED allows normal operation.  
OPEN disables the control and motor coasts to a stop.
- J1-9 Momentary CLOSED starts motor operation in the Forward direction.
- J1-10 Momentary CLOSED starts motor operation in the Reverse direction.  
 Note: Closing both J1-9 and J1-10 at the same time will reset a fault condition.
- J1-11 Momentary OPEN motor decels to stop (depending on Keypad Stop mode).
- J1-12 CLOSED selects Level 1 Command Select parameter value.  
OPEN selects EPOT.
- J1-13 CLOSED selects ACC / DEC / S-CURVE group 2.  
OPEN selects ACC / DEC / S-CURVE group 1.
- J1-14 Momentary CLOSED increases motor speed while contact is closed.
- J1-15 Momentary CLOSED decreases motor speed while contact is closed.
- J1-16 If J1-16 is connected, you must set Level 2 Protection block, External Trip to "ON" to activate the opto input.  
CLOSED allows normal operation.  
OPEN causes an external trip fault. The control will disable and the motor coasts to a stop. An external trip fault is displayed (also logged in the fault log).



See recommended terminal tightening torques in Section 7.

Refer to Figure 3-41.

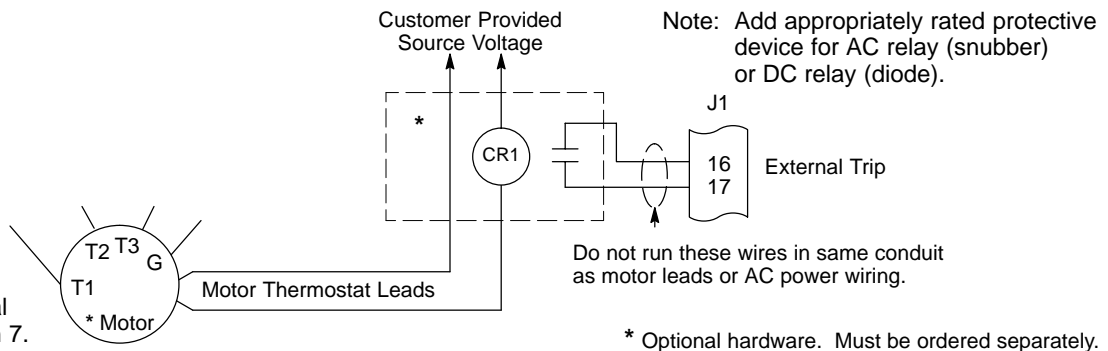
## External Trip Input

Terminal J1-16 is available for connection to a normally closed thermostat or overload relay in all operating modes as shown in Figure 3-41. The thermostat or overload relay should be a dry contact type with no power available from the contact. If the motor thermostat or overload relay activates, the control will automatically shut down and give an External Trip fault. The optional relay (CR1) shown provides the isolation required and the N.O. contact is open when power is applied to the relay and the motor is cold. If the motor thermostat is tripped, CR1 is de-energized and the N.O. contact closes.

Connect the External Trip Input wires (N.O. relay contact) to J1-16 and J1-17. Do not place these wires in the same conduit as the motor power leads.

To activate the External Trip input, the External Trip parameter in the Level 2 Protection Block must be set to "ON".

**Figure 3-41 Motor Temperature Relay**

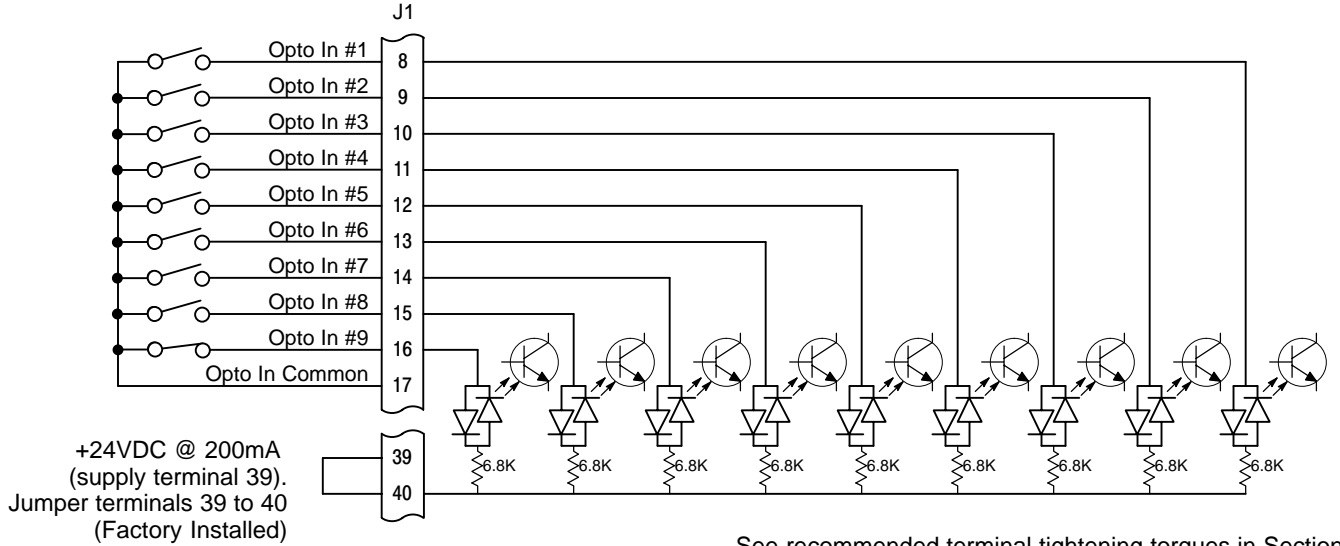


See recommended terminal tightening torques in Section 7.

## Opto-Isolated Inputs

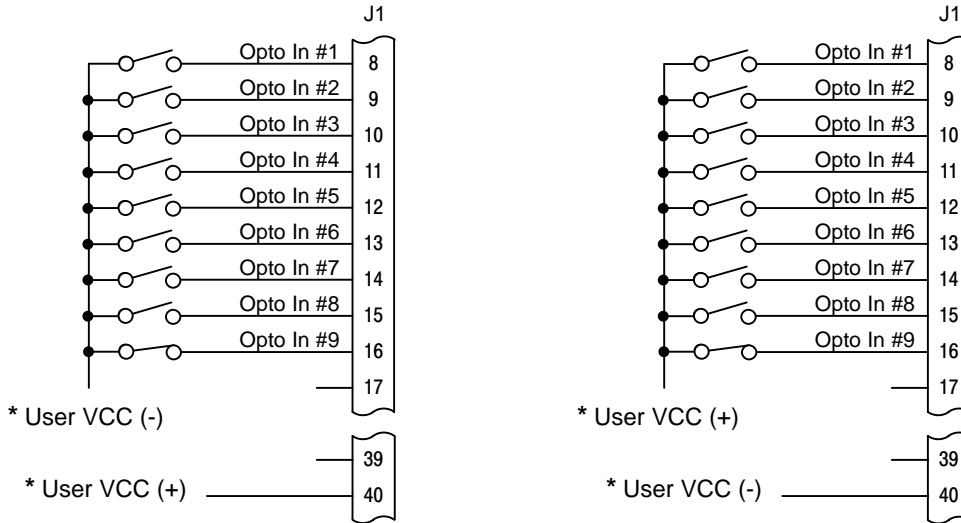
The equivalent circuit of the nine opto inputs is shown in Figure 3-42. The function of each input depends on the operating mode selected and are described previously in this section. This Figure also shows the connections using the internal opto input Supply.

**Figure 3-42 Opto-Input Connections (Using Internal Supply)**



See recommended terminal tightening torques in Section 7.

**Figure 3-43 Opto-Input Connections (Using External Supply)**



**Opto Inputs Closing to Ground**

**Opto Inputs Closing to +VCC**

\* User VCC = 10 - 30VDC External Power Source

See recommended terminal tightening torques in Section 7.



## Opto-Isolated Outputs

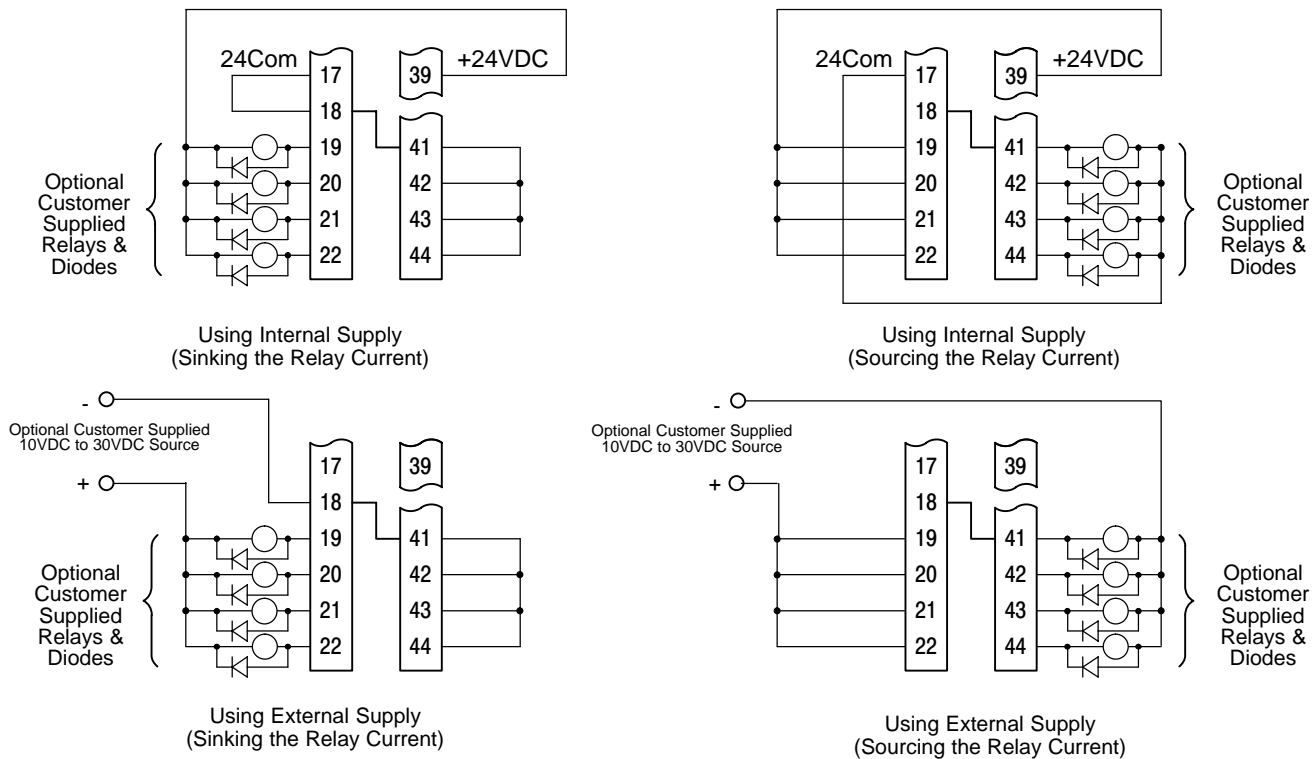
Four programmable opto isolated outputs are available at terminals J1-19 through J1-22. See Figure 3-44. Each output may be programmed to represent one output condition. The output conditions are defined in Section 4 of this manual.

The opto isolated outputs may be configured for sinking or sourcing 60 mA each, as shown in Figure 3-44. However, all must be configured the same. The maximum voltage from opto output to common when active is 1.0 VDC (TTL compatible). The equivalent circuit for the opto isolated outputs is shown in Figure 3-45.

If the opto outputs are used to directly drive a relay, a flyback diode rated at 1A, 100 V (IN4002 or equivalent) minimum should be connected across the relay coil.

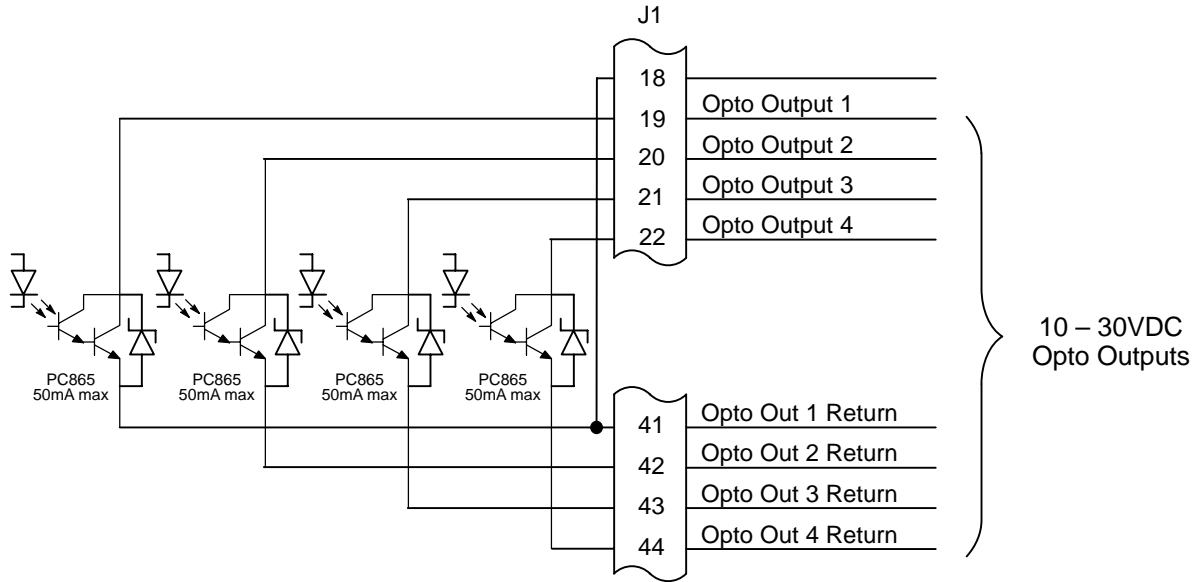
Each opto output is programmed in the Output programming block.

**Figure 3-44 Opto-isolated Output Configurations**



See recommended terminal tightening torques in Section 7.

**Figure 3-45 Opto-Output Equivalent Circuit**



See recommended Terminal Tightening Torques in Section 7.

**Pre-Operation Checklist**

**Check of Electrical Items**

1. Verify AC line voltage at source matches control rating.
2. Inspect all power connections for accuracy, workmanship and torque as well as compliance to codes.
3. Verify control and motor are grounded to each other and the control is connected to earth ground.
4. Check all signal wiring for accuracy.
5. Be certain all brake coils, contactors and relay coils have noise suppression. This should be an R-C filter for AC coils and reverse polarity diodes for DC coils. MOV type transient suppression is not adequate.

**Check of Motors and Couplings**

1. Verify freedom of motion of the motor shaft.
2. Verify that the motor coupling is tight without backlash.
3. Verify the holding brakes if any, are properly adjusted to fully release and set to the desired torque value.

---

## Power-Up Procedure

Be sure the 23H control, motor and dynamic brake hardware are installed and wired according to the procedures in Section 3 of this manual. Become familiar with the keypad programming and keypad operation of the control as described in Section 4 of this manual.

1. Disconnect the load (including coupling or inertia wheels) from the motor shaft, if possible.
2. Verify that any enable inputs to J1-8 are open. Be sure Level 2 Protection block, Local Enable INP is OFF and Level 2 Protection block, External Trip is OFF.
3. Turn power on. Be sure no errors are displayed.
4. Set the Level 1 Input block, Operating Mode parameter to "KEYPAD".
5. Set the Level 2 Output Limits block, "OPERATING ZONE" parameter as desired (STD CONST TQ, STD VAR TQ, QUIET CONST TQ or QUIET VAR TQ).
6. Enter the following motor data in the Level 2 Motor Data block parameters:  
Motor Rated Amps (IC)  
Motor Poles  
Resolver Speeds (Pre-set is one speed)
7. If external dynamic brake hardware is used, set the Level 2 Brake Adjust block "Resistor Ohms", "Resistor Watts" and "DC Brake Current" parameters.
8. If the load was not disconnected in step 1, refer to Section 6 and manually tune the control. After manual tuning, perform steps 11 and 12 then continue with step 16.
9. At the Level 2 Motor Data block, press ENTER, at CALC PRESETS select YES (using the ▲ key) and let the control calculate preset values for the parameters that are necessary for control operation.

**⚠ WARNING: The motor shaft will rotate during the autotune procedure. Be certain that unexpected motor shaft movement will not cause injury to personnel or damage to equipment.**

10. Go to Level 2 Autotune block, and perform the following tests:  
CMD OFFSET TRIM  
CUR LOOP COMP  
RESOLVER ALIGN
11. Set the Level 2 Output Limits block, "MIN OUTPUT SPEED" parameter.
12. Set the Level 2 Output Limits block, "MAX OUTPUT SPEED" parameter.
13. Remove all power from the control.
14. Couple the motor to its load.
15. Turn power on. Be sure no errors are displayed.
16. Perform the SPD CNTRLR CALC test in the Level 2 Autotune block.
17. Run the drive from the keypad using the arrow keys for direct speed control, a keypad entered speed or the JOG mode.
18. Select and program additional parameters to suit your application.

The control is now ready for use in keypad mode. If a different operating mode is desired, refer to Section 3 Control Connections and Section 4 Programming and Operation.

# Section 4

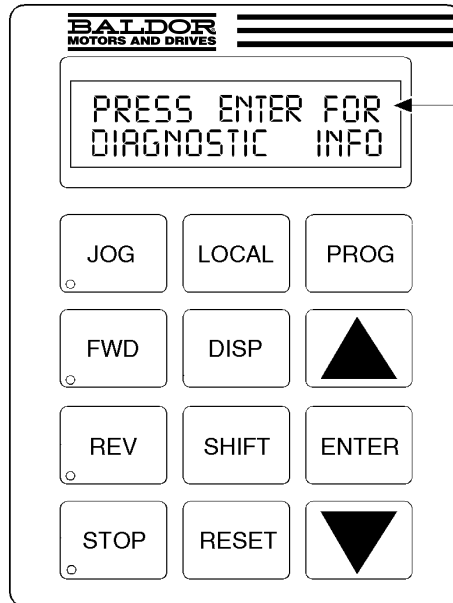
## Programming and Operation

### Overview

The keypad is used to program the control parameters, to operate the motor and to monitor the status and outputs of the control by accessing the display options, the diagnostic menus and the fault log.

**Figure 4-1 Keypad**

JOG - (Green) lights when Jog is active.  
 FWD - (Green) lights when FWD direction is commanded.  
 REV - (Green) lights when REV direction is commanded.  
 STOP - (Red) lights when motor STOP is commanded.  
 Indicator Lights



**Keypad Display** - Displays status information during Local or Remote operation. It also displays information during parameter setup and fault or Diagnostic Information.

**JOG** - Press JOG to select the preprogrammed jog speed. After the jog key has been pressed, use the FWD or REV keys to run the motor in the direction that is needed. The JOG key is only active in the local mode.

**FWD** - Press FWD to initiate forward rotation of the motor.

**REV** - Press REV to initiate reverse rotation of the motor.

**STOP** - Press STOP one time to initiate a stop sequence. Depending on the Keypad Stop Mode, the motor will either REGEN or COAST to a stop. This key is operational in all modes of operation unless disabled by the Keypad Stop parameter in the Keypad (programming) Setup Block. Press STOP twice to disable control (coast to stop).

**LOCAL** - Press LOCAL to change between the local (keypad) and remote operation. When the control is in the local mode all other external commands to the J1 terminal strip will be ignored with the exception of the external trip input.

**DISP** - Press DISP to return to display mode from programming mode. Provides operational status and advances to the next display menu item including the Diagnostic Screens.

**SHIFT** - Press SHIFT in the program mode to control cursor movement. Pressing the SHIFT key once moves the blinking cursor one character position to the right. While in program mode, a parameter value may be reset to the factory preset value by pressing the SHIFT key until the arrow symbols at the far left of the keypad display are flashing, then press an arrow key. In the display mode the SHIFT key is used to adjust the keypad contrast.

**RESET** - Press RESET to clear all fault messages (in local mode). Can also be used to return to the top of the block programming menu without saving any parameter value changes.

**PROG** - Press PROG to enter the program mode. While in the program mode the PROG key is used to edit a parameter setting.

**▲ - (UP Arrow)**.  
 Press ▲ to change the value of the parameter being displayed. Pressing ▲ increments the value to the next greater value. Also, when the fault log or parameter list is displayed, the ▲ key will scroll upward through the list. In the local mode pressing the ▲ key will increase motor speed to the next greater value.

**ENTER** - Press ENTER to save parameter value changes and move back to the previous level in the programming menu. In the display mode the ENTER key is used to directly set the local speed reference. It is also used to select other operations when prompted by the keypad display.

**▼ - (Down Arrow)**  
 Press ▼ to change the value of the parameter being displayed. Pressing ▼ decrements the value to the next lesser value. Also, when the fault log or parameter list is displayed, the ▼ key will scroll downward through the list. In the local mode pressing the ▼ key will decrease motor speed to the next lower value.

## Display Mode

The control is in the DISPLAY MODE at all times except when parameter values are changed (Programming mode). The Keypad Display shows the status of the control as in the following example.



The DISPLAY MODE is used to view operating status, Diagnostic INFO, the Fault Log and to adjust the Display contrast. The description of how to do these tasks are described on the following pages.

**Adjusting Display Contrast** When AC power is applied to the control, the keypad should display the status of the control. If there is no visible display, use the following procedure to adjust the contrast of the display. Contrast may be adjusted in display mode when motor is stopped or running.

Action	Description	Display	Comments
Apply Power	No visible display		
Press DISP Key	Places control in display mode		
Press SHIFT SHIFT	Allows display contrast adjustment		
Press ▲ or ▼ Key	Adjusts display intensity		
Press ENTER	Saves level of contrast and exits to display mode		Typical display

## Display Mode Screens

Action	Description	Display	Comments
Apply Power			Logo display for 5 seconds.
	Display mode showing motor speed.		No faults present. Local keypad mode. If in remote/serial mode, press local for this display.
Press DISP key	Display Frequency		First Display Mode Screen.
Press DISP key	Display Current		
Press DISP key	Display Voltage		
Press DISP key	Combined Display		
Press DISP key	Screen to enter Fault Log		
Press DISP key	Screen to enter Diagnostic Menu		

Display Mode Continued

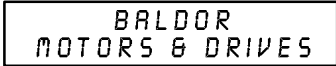




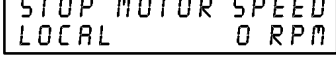
**Diagnostic Information Access**

Action	Description	Display	Comments
Press DISP key	Scroll to Diagnostic Information screen	<pre>PRESS ENTER FOR DIAGNOSTIC INFO</pre>	Diagnostic Access screen.
Press ENTER key	Access diagnostic information.	<pre>STOP SPEED REF LOCAL 0 RPM</pre>	First Diagnostic Information screen.
Press DISP key	Display mode showing control temperature.	<pre>STOP CONTROL TEMP LOCAL 0.0° C</pre>	
Press DISP key	Display mode showing bus voltage.	<pre>STOP BUS VOLTAGE LOCAL XXXV</pre>	
Press DISP key	Display mode showing % overload current remaining.	<pre>STOP OVRLD LEFT LOCAL 100.00%</pre>	
Press DISP key	Display mode showing opto inputs & outputs states. (0=Open, 1=Closed.)	<pre>DIGITAL I/O 00000000 0000</pre>	Opto Inputs states (Left); Opto Outputs states (Right).
Press DISP key	Display mode showing actual time the drive has been powered up.	<pre>TIME FROM PUR UP 0000000.01.43</pre>	HR.MIN.SEC format.
Press DISP key	Display mode showing operating zone, voltage and control type.	<pre>QUIET VAR TQ XXXV SERVO</pre>	Typical display.
Press DISP key	Display mode showing continuous amps; PK amps rating; amps/volt scale of feedback, power base ID.	<pre>X.XA X.X APK X.XX A/V ID:XXX</pre>	
Press DISP key	Display mode showing which Group1 or 2 expansion boards are installed and recognized.	<pre>G1 NOT INSTALLED G2 NOT INSTALLED</pre>	In this case, no expansion boards are installed.
Press DISP key	Display mode showing position counter contents.	<pre>POSITION COUNTER + 000.00000 REV</pre>	
Press DISP key	Display mode showing parameter table selected.	<pre>STOP TABLE LOCAL 0</pre>	
Press DISP key	Display mode showing software version and revision installed in the control.	<pre>SOFTWARE VERSION SXX-X.XX</pre>	
Press DISP key	Displays exit choice.	<pre>PRESS ENTER FOR DIAGNOSTIC EXIT</pre>	Press ENTER to exit diagnostic information.

**Display Mode** Continued

**Fault Log Access**

When a fault condition occurs, motor operation stops and a fault code is displayed on the Keypad display. The control keeps a log of up to the last 31 faults. If more than 31 faults have occurred, the oldest fault will be deleted from the fault log to make room for the newest fault. To access the fault log perform the following procedure:

Action	Description	Display	Comments
Apply Power			Logo display for 5 seconds.
	Display mode showing motor speed.		Display mode.
Press DISP key	Scroll to the Fault Log screen		Fault Log access screen.
Press ENTER key	Display first fault type and time fault occurred.		1=Most recent fault displayed. 2=Second most recent fault, etc.
Press ▲ key	Scroll through fault messages.		If no messages, the fault log exit choice is displayed.
Press ENTER key	Return to display mode.		Display mode. Stop key LED is on.

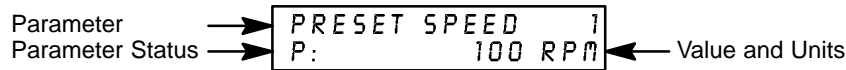
## Program Mode

The Program Mode is used to:

1. Enter motor data.
2. Autotune the drive.
3. Customize the drive (Control and Motor) parameters to your application.

From the Display Mode press the PROG key to access the Program Mode.

Note: When a parameter is selected, alternately pressing the Disp and Prog keys will toggle between the Display Mode and the selected parameter. When a parameter is selected for programming, the keypad display gives you the following information:



**Parameter Status.** All programmable parameters are displayed with a “P:” in the lower left corner of the keypad display. If a parameter is displayed with a “V:”, the parameter value may be viewed but not changed while the control is enabled. If the parameter is displayed with an “L:”, the value is locked and the security access code must be entered before its’ value can be changed.

## Parameter Blocks Access for Programming

Use the following procedure to access parameter blocks to program the control.

Action	Description	Display	Comments
Apply Power	Keypad Display shows this opening message.	<pre>BALDOR MOTORS &amp; DRIVES</pre>	Logo display for 5 seconds.
	If no faults and programmed for LOCAL operation.	<pre>STOP MOTOR SPEED LOCAL 0 RPM</pre>	Display mode.
	If no faults and programmed for REMOTE operation.	<pre>STOP MOTOR SPEED REMOTE 0 RPM</pre>	If fault is displayed, refer to the Troubleshooting section of this manual.
Press PROG key		<pre>PRESS ENTER FOR PRESET SPEEDS</pre>	Press ENTER to access Preset Speed parameters.
Press ▲ or ▼ key	Scroll to the ACCEL/DECEL block.	<pre>PRESS ENTER FOR ACCEL/DECEL RATE</pre>	Press ENTER to access Accel and Decel rate parameters.
Press ▲ or ▼ key	Scroll to the Level 2 Block.	<pre>PRESS ENTER FOR LEVEL 2 BLOCKS</pre>	Press ENTER to access Level 2 Blocks.
Press ENTER key	First Level 2 block display.	<pre>PRESS ENTER FOR OUTPUT LIMITS</pre>	
Press ▲ or ▼ key	Scroll to Programming Exit menu.	<pre>PRESS ENTER FOR PROGRAMMING EXIT</pre>	Press ENTER to return to Display mode.
Press ENTER key	Return to display mode.	<pre>STOP MOTOR SPEED LOCAL 0 RPM</pre>	

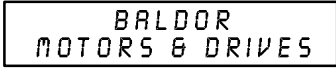



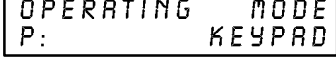
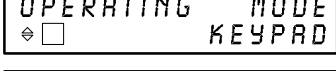
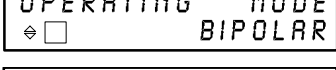
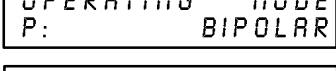
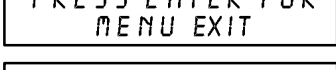
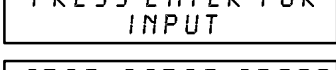
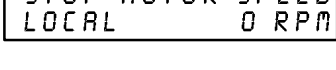


**Program Mode** Continued

**Changing Parameter Values when Security Code Not Used**

Use the following procedure to program or change a parameter already programmed into the control when a security code is not being used.

The example shown changes the operating mode from Keypad to Bipolar.

Action	Description	Display	Comments
Apply Power	Keypad Display shows this opening message.		Logo display for 5 seconds.
	If no faults and programmed for LOCAL operation.		Display mode. Stop LED on.
Press PROG key	Access programming mode.		
Press ▲ or ▼ key	Scroll to Level 1 Input Block.		Press ENTER to access INPUT block parameter.
Press ENTER key	Access Input Block.		Keypad mode shown is the factory setting.
Press ENTER key	Access Operating Mode parameter.		Keypad mode shown is the factory setting.
Press ▲ key	Scroll to change selection.		At flashing cursor, select desired mode, BIPOLAR in this case.
Press ENTER	Save selection to memory.		Press ENTER to save selection.
Press ▲ key	Scroll to menu exit.		
Press ENTER key	Return to Input Block.		
Press DISP key	Return to Display Mode.		Typical display mode.

**Program Mode** Continued

**Reset Parameters to Factory Settings**

Sometimes it is necessary to restore the parameter values to the factory settings. Follow this procedure to do so. Be sure to change the Level 2 Motor Data block "Motor Rated Amps" to the correct value after this procedure (restored factory setting is 999).

Note: All parameter values are changed when the control is reset to factory settings.

Note: After factory settings have been restored, the drive must again be tuned.

Action	Description	Display	Comments
Apply Power	Keypad Display shows this opening message.	<pre>BALDOR MOTORS &amp; DRIVES</pre>	Logo display for 5 seconds.
	If no faults and programmed for LOCAL operation.	<pre>STOP MOTOR SPEED LOCAL          0 RPM</pre>	Display mode. Stop LED on.
Press PROG key	Enter program mode.	<pre>PRESS ENTER FOR PRESET     SPEEDS</pre>	
Press ▲ or ▼ key	Scroll to Level 2 Blocks.	<pre>PRESS ENTER FOR LEVEL 2   BLOCKS</pre>	
Press ENTER key	Select Level 2 Blocks.	<pre>PRESS ENTER FOR OUTPUT LIMITS</pre>	
Press ▲ or ▼ key	Scroll to the Miscellaneous block.	<pre>PRESS ENTER FOR MISCELLANEOUS</pre>	
Press ENTER key	Select Miscellaneous block.	<pre>RESTART AUTO/MAN P:          MANUAL</pre>	
Press ▲ key	Scroll to Factory Settings parameter.	<pre>FACTORY SETTINGS P:          NO</pre>	
Press ENTER key	Access Factory Settings parameter.	<pre>FACTORY SETTINGS <math>\updownarrow</math> <input type="checkbox"/> NO</pre>	<input type="checkbox"/> represents blinking cursor.
Press ▲ key	Scroll to YES, to choose original factory settings.	<pre>FACTORY SETTINGS <math>\updownarrow</math> <input type="checkbox"/> YES</pre>	
Press ENTER key	Restores factory settings.	<pre>FACTORY SETTINGS P:LOADING PRESETS</pre>	"Loading Presets" is first message "Operation Done" is next "No" is displayed last.
Press ▲ key	Scroll to menu exit.	<pre>PRESS ENTER FOR MENU EXIT</pre>	Exit Level 2 blocks.
Press ENTER key	Return to Level 1 blocks.	<pre>PRESS ENTER FOR LEVEL 2   BLOCKS</pre>	Exit Level 2 blocks.
Press ▲ or ▼ key	Scroll to Programming exit.	<pre>PRESS ENTER FOR PROGRAMMING EXIT</pre>	Exit Programming mode and return to Display mode.
Press ENTER key	Return to display mode.	<pre>STOP MOTOR SPEED LOCAL          0 RPM</pre>	Display mode. Stop LED on.

**Program Mode** Continued

**Initialize New Software**

When new software is installed, the control must be initialized to the new software version and memory locations. Use the following procedure to initialize the software.

Note: All parameter values are changed when the control is reset to factory settings.

Note: After factory settings have been restored, the drive must again be tuned.

Action	Description	Display	Comments
Apply Power	Keypad Display shows this opening message.	<pre>BALDOR MOTORS &amp; DRIVES</pre>	Logo display for 5 seconds.
	If no faults and programmed for LOCAL operation.	<pre>STOP MOTOR SPEED LOCAL          0 RPM</pre>	Display mode. Stop LED on.
Press PROG key	Enter program mode.	<pre>PRESS ENTER FOR PRESET     SPEEDS</pre>	
Press ▲ or ▼ key	Scroll to Level 2 Blocks.	<pre>PRESS ENTER FOR LEVEL 2    BLOCKS</pre>	
Press ENTER key	Select Level 2 Blocks.	<pre>PRESS ENTER FOR OUTPUT LIMITS</pre>	
Press ▲ or ▼ key	Scroll to the Miscellaneous block.	<pre>PRESS ENTER FOR MISCELLANEOUS</pre>	
Press ENTER key	Select Miscellaneous block.	<pre>RESTART AUTO/MAN P:          MANUAL</pre>	
Press ▲ key	Scroll to Factory Settings parameter.	<pre>FACTORY SETTINGS P:          NO</pre>	
Press ENTER key	Access Factory Settings parameter.	<pre>FACTORY SETTINGS <math>\updownarrow</math> <input type="checkbox"/> NO</pre>	<input type="checkbox"/> represents blinking cursor.
Press ▲ key	Scroll to YES, to choose original factory settings.	<pre>FACTORY SETTINGS <math>\updownarrow</math> <input type="checkbox"/> YES</pre>	
Press ENTER key	Restores factory settings.	<pre>FACTORY SETTINGS P:LOADING PRESETS</pre>	"Loading Presets" is first message "Operation Done" is next "No" is displayed last.
Press ▲ key	Scroll to menu exit.	<pre>PRESS ENTER FOR MENU EXIT</pre>	
Press ENTER key	Return to display mode.	<pre>STOP MOTOR SPEED LOCAL          0 RPM</pre>	Display mode. Stop LED on.
Press ▲ key	Scroll to diagnostic info block.	<pre>PRESS ENTER FOR DIAGNOSTIC INFO</pre>	
Press ENTER key	Access diagnostic information.	<pre>STOP SPEED   REF LOCAL        0 RPM</pre>	Displays commanded speed, direction of rotation, Local/ Remote and motor speed.
Press DISP key	Display mode showing software version and revision installed in the control.	<pre>SOFTWARE VERSION XXX-X.XX</pre>	Verify new software version.
Press DISP key	Displays exit choice.	<pre>PRESS ENTER FOR DIAGNOSTIC EXIT</pre>	Press ENTER to exit diagnostic information.

## Parameter Definitions

To make programming easier, parameters have been arranged into the two level structure shown in Table 4-1. Press the PROG key to enter the programming mode and the “Preset Speeds” programming block will be displayed. Use the Up (▲) and Down (▼) arrows to scroll through the parameter blocks. Press ENTER to access parameters within a programming block.

Tables 4-2 and 4-3 provide an explanation of each parameter. A complete Parameter Block Values list is located at the end of this manual. This list defines the programmable range and factory preset value for each parameter. The list has a space to record your settings for future reference.

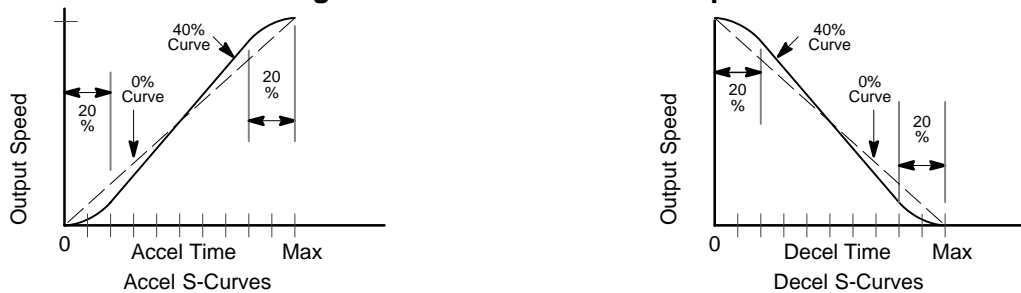
**Table 4-1 List of Parameters** (Version 3.12)

LEVEL 1 BLOCKS		LEVEL 2 BLOCKS	
<b>Preset Speeds</b>	<b>Input</b>	<b>Output Limits</b>	<b>Brake Adjust</b>
Preset Speed #1	Operating Mode	Operating Zone	Resistor Ohms
Preset Speed #2	Command Select	Min Output Speed	Resistor Watts
Preset Speed #3	ANA CMD Inverse	Max Output Speed	
Preset Speed #4	ANA CMD Offset	PK Current Limit	<b>Process Control</b>
Preset Speed #5	ANA 2 Deadband	PWM Frequency	Process Feedback
Preset Speed #6	ANA1 CUR Limit	CUR Rate Limit	Process Inverse
Preset Speed #7			Setpoint Source
Preset Speed #8	<b>Output</b>	<b>Custom Units</b>	Setpoint Command
Preset Speed #9	Opto Output #1	Max. Decimal Places	Set PT ADJ Limit
Preset Speed #10	Opto Output #2	Value at Speed	Process ERR TOL
Preset Speed #11	Opto Output #3	Units of Measure	Process PROP Gain
Preset Speed #12	Opto Output #4		Process INT Gain
Preset Speed #13	Zero SPD Set PT	<b>Protection</b>	Process DIFF Gain
Preset Speed #14	At Speed Band	Overload	Follow I:O Ratio
Preset Speed #15	Set Speed	External Trip	Follow I:O OUT
	Analog Out #1	Local Enable INP	Master Encoder
<b>Accel / Decel Rate</b>	Analog Out #2	Following Error	
Accel Time #1	Analog #1 Scale		<b>Communications</b>
Decel Time #1	Analog #2 Scale	<b>Miscellaneous</b>	Protocol
S-Curve #1	Position Band	Restart Auto/Man	Baud Rate
Accel Time #2		Restart Fault/Hr	Drive Address
Decel Time #2	<b>Brushless Control</b>	Restart Delay	
S-Curve #2	Resolver Align	Factory Settings	<b>Auto-Tuning</b>
	Speed Filter	Homing Speed	CALC Presets
<b>Jog Settings</b>	Feedback Align	Homing Offset	CMD Offset Trim
Jog Speed	Current PROP Gain		CUR Loop Comp
Jog Accel Time	Current INT Gain	<b>Security Control</b>	Feedback Align
Jog Decel Time	Speed PROP Gain	Security State	SPD CNTRLR Calc
Jog S-Curve Time	Speed INT Gain	Access Timeout	
	Speed DIFF Gain	Access Code	
<b>Keypad Setup</b>	Position Gain		
Keypad Stop Key		<b>Motor Data</b>	
Keypad Stop Mode		Motor Rated Amps	
Keypad Run Fwd		Motor Poles	
Keypad Run Rev		Resolver Speeds	
Keypad Jog Fwd		CALC Presets	
Keypad Jog Rev			
Local Hot Start			

**Table 4-2 Level 1 Parameter Block Definitions**

Block Title	Parameter	Description
PRESET SPEEDS	Preset Speeds #1 – #15	Allows selection of 15 predefined motor operating speeds. Each speed may be selected using external switches connected to terminals at J1. For motor operation, a motor direction command must be given along with a preset speed command.
ACCEL/DECEL RATE	Accel Time #1,2 Decel Time #1,2 S-Curve #1,2	<p>Accel time is the number of seconds required for the motor to increase at a linear rate from 0 RPM to the RPM specified in the “Max Output Speed” parameter in the Level 2 Output Limits block.</p> <p>Decel time is the number of seconds required for the motor to decrease at a linear rate from the speed specified in the “Max Output Speed” parameter to 0 RPM.</p> <p>S-Curve is a percentage of the total Accel and Decel time and provides smooth starts and stops. Half of programmed S-Curve % applies to Accel and half to Decel ramps. 0% represents no “S” and 100% represents full “S” with no linear segment.</p> <p>Note: Accel #1, Decel #1 and S-Curve #1 are associated together. Likewise, Accel #2, Decel #2 and S-Curve #2 are associated together. These associations can be used to control any Preset Speed or External Speed command.</p> <p>Note: If drive faults occur during rapid Accel or Decel, selecting an S-curve may eliminate the faults.</p>
JOG SETTINGS	Jog Speed Jog Accel Time Jog Decel Time Jog S-Curve	<p>Jog Speed is the programmed speed used for jog. Jog can be initiated from the keypad or terminal strip. At the Keypad, press the JOG key then press and hold the FWD or REV key. At the terminal strip, close the JOG input (J1-12) then close the FWD or REV input (J1-9 or J1-10).</p> <p>In Process Mode, if the Jog key is pressed or J1-12 is closed the drive will move in the direction of the error without pressing FWD or REV.</p> <p>Jog Accel Time changes the Slope of the Jog Accel ramp. It is the time in seconds from zero speed to maximum speed.</p> <p>Jog Decel Time changes the Slope of the Jog Decel ramp. It is the time in seconds from maximum speed to zero speed.</p> <p>Jog S-Curve changes the S-Curve to a new preset value for jog mode.</p>

**Figure 4-2 40% S-Curve Example**



**Table 4-2 Level 1 Parameter Block Definitions - Continued**

Block Title	Parameter	Description
KEYPAD SETUP	Keypad Stop Key	Allows keypad STOP key to initiate motor stop during remote or serial operation (if Stop key is set to Remote ON in Standard Run, 15 Speed, Bipolar, Serial and Process Control modes). If active, pressing STOP automatically selects Local mode and initiates the stop command.
	Keypad Stop Mode	Selects if the Stop command causes the motor to COAST to a stop or REGEN to a stop. In COAST, the motor is turned off and allowed to coast to a stop. In REGEN, the voltage and frequency to the motor is reduced at a rate set by Decel Time.
	Keypad Run FWD	ON makes the keypad FWD key active in Local mode.
	Keypad Run REV	ON makes the keypad REV key active in Local mode.
	Keypad Jog FWD	ON makes the keypad FWD key active in Local Jog mode.
	Keypad Jog REV	ON makes the keypad REV key active in Local Jog mode.
	Loc. Hot Start	The STOP input at J1-11 in the Keypad mode is enabled (when ON).
INPUT	Operating Mode	Ten "Operating Modes" are available. Choices are: Keypad, Standard Run, 15SPD, Serial, Bipolar, Process, 3 SPD ANA 2 wire, 3 SPD ANA 3 wire, EPOT - 2 Wire and EPOT - 3 Wire. External connections to the control are made at the J1 terminal strip (wiring diagrams are shown in Section 3 "Control Circuit Connections").
	Command Select	Selects the external speed reference to be used. The easiest method of speed control is to select POTENTIOMETER and connect a 5K $\Omega$ pot to J1-1, J1-2, and J1-3. $\pm 5$ , $\pm 10$ VDC or 4-20mA input command can be applied to J1-4 and J1-5. If long distance is required between the external speed control and the control, the 4-20mA selections at J1-4 and J1-5 should be considered. Current loop allows long cable lengths without attenuation of the command signal. 10 VOLT W/TORQ FF - when a differential command is present at J1-4 and 5, allows additional 5V torque feedforward input at J1-1, 2 and 3 to set a predetermined amount of torque inside the rate loop with high gain settings. EXB PULSE FOL - selects optional Master Pulse Reference/Isolated Pulse Follower expansion board if installed. 5VOLT EXB - selects optional High Resolution I/O expansion board if installed. 10VOLT EXB - selects optional High Resolution I/O expansion board if installed. 4-20mA EXB - selects optional High Resolution I/O expansion board if installed. 3-15 PSI EXB selects optional 3-15 PSI expansion board if installed. Tachometer EXB- selects optional DC Tachometer expansion board if installed. Serial -selects optional Serial Communications expansion board if installed. None - Used in Process Control mode, two input configuration with no Feedforward input. Note: When using the 4-20mA input, the JP2 jumper on the main control board must be moved to the left two pins "A".
	ANA CMD Inverse	"OFF" will cause a low input voltage (e.g. 0VDC) to be a low motor speed command and a maximum input voltage (e.g. 10VDC) to be a maximum motor speed command. "ON" will cause a low input voltage (e.g. 0VDC) to be a maximum motor speed command and a maximum input voltage (e.g. 10VDC) to be a low motor speed command.
	ANA CMD Offset	Provides an offset to the Analog Input to minimize signal drift. For example, if the minimum speed signal is 1VDC (instead of 0VDC) the ANA CMD Offset can be set to -10% so the minimum voltage input is seen by control as 0VDC. The value of this parameter is automatically adjusted during Autotune "CMD Offset Trim" test.
	ANA 2 Deadband	Allows a defined range of voltage to be a deadband. A command signal within this range will not affect the control output. The deadband value is the voltage above and below the zero command signal level.
	ANA 1 CUR Limit	Allows the 5V input at J1-2 (referenced to J1-1) to be used for reduction of the programmed current limit parameter for torque trimming during operation.

**Table 4-2 Level 1 Parameter Block Definitions - Continued**

Block Title	Parameter	Description																																				
OUTPUT	OPTO OUTPUT #1 – #4	<p>Four optically isolated digital outputs that have two operating states, logical High or Low. Each output may be configured to any of the following conditions:</p> <table border="0"> <thead> <tr> <th data-bbox="573 373 686 405">Condition</th> <th data-bbox="781 373 914 405">Description</th> </tr> </thead> <tbody> <tr> <td data-bbox="573 415 654 447">Ready -</td> <td data-bbox="781 415 1369 447">Active when power is applied and no faults are present.</td> </tr> <tr> <td data-bbox="573 457 711 489">Zero Speed -</td> <td data-bbox="781 457 1471 510">Active when motor RPM is below the value of the Level 1 Output “Zero SPD Set Pt” parameter.</td> </tr> <tr> <td data-bbox="573 520 686 552">At Speed -</td> <td data-bbox="781 520 1450 573">Active when output speed is within the speed range defined by the Level 1 Output “At Speed Band” parameter.</td> </tr> <tr> <td colspan="2" data-bbox="589 583 1433 636">Note: In the torque command mode, the At Speed opto output is always in the “OFF” state.</td> </tr> <tr> <td data-bbox="573 646 686 678">Overload -</td> <td data-bbox="781 646 1401 699">Active during an Overload fault caused by a time out when output current is greater than Rated Current.</td> </tr> <tr> <td data-bbox="573 709 751 741">Keypad Control -</td> <td data-bbox="781 709 1271 741">Active when control is in Local keypad control.</td> </tr> <tr> <td data-bbox="573 751 727 783">At Set Speed -</td> <td data-bbox="781 751 1417 804">Active when output speed is at or above the Level 1 Output “Set Speed” parameter.</td> </tr> <tr> <td data-bbox="573 814 638 846">Fault -</td> <td data-bbox="781 814 1206 846">Active when a fault condition is present.</td> </tr> <tr> <td data-bbox="573 856 743 888">Following ERR -</td> <td data-bbox="781 856 1401 909">Active when the motor speed is outside the user specified tolerance band defined by the At Speed Band parameter.</td> </tr> <tr> <td data-bbox="573 919 751 951">Motor Direction -</td> <td data-bbox="781 919 1471 972">Active High when REV direction command received. Active Low when FWD direction command received.</td> </tr> <tr> <td data-bbox="573 982 686 1014">Drive On -</td> <td data-bbox="781 982 1471 1035">Active when control is “Ready” (has reached excitation level and capable of producing torque).</td> </tr> <tr> <td data-bbox="573 1045 743 1077">CMD Direction -</td> <td data-bbox="781 1045 1417 1098">Active at all times. Logical output state indicates Forward or Reverse direction. High=FWD, Low=REV.</td> </tr> <tr> <td data-bbox="573 1108 703 1140">At Position -</td> <td data-bbox="781 1108 1450 1161">Active during a positioning command when control is within the position band parameter tolerance.</td> </tr> <tr> <td data-bbox="573 1171 760 1203">Over Temp Warn -</td> <td data-bbox="781 1171 1401 1203">Active when control heat sink is within 3°C of Int Overtemp.</td> </tr> <tr> <td data-bbox="573 1213 735 1245">Process Error -</td> <td data-bbox="781 1213 1417 1308">Active when process feedback signal is outside the range specified by the Level 2 Process Control block, AT Setpoint Band parameter. Turns off when process feedback error is eliminated.</td> </tr> <tr> <td data-bbox="573 1318 686 1350">Drive Run -</td> <td data-bbox="781 1318 1471 1371">Active when drive is Ready, Enabled, Speed or Torque command received with FWD/REV direction issued.</td> </tr> <tr> <td data-bbox="573 1381 654 1413">Serial -</td> <td data-bbox="781 1381 1206 1413">Active when drive is in the Serial mode.</td> </tr> </tbody> </table> <p data-bbox="302 1413 521 1497">Zero SPD Set PT Sets the speed at which the Zero Speed opto output becomes active (turns on). When the speed is less than the ZERO SPD SET PT, the Opto Output becomes active. This is useful when a motor brake is to interlock operation with a motor.</p> <p data-bbox="302 1507 521 1791">At Speed Band The At Speed Band serves two Opto Output Conditions and the Level 2 Protection block Following Error: Sets the speed range in RPM at which the At Speed opto output turns on and remains active within the range. Sets the Following Error Tolerance Band for the Level 1 OUTPUT, Opto Output condition Following ERR. The opto output is active if the motor speed is outside this band. Sets the no fault operating speed range of the drive. This value is used by the Level 2 Protection block, Following Error parameter (if it is set to ON). If the drive speed falls out of this band, the Level 2 Protection block, Following Error parameter will shut down the drive (if it is set to ON).</p> <p data-bbox="302 1801 521 1892">Set Speed Sets the speed that the At Set Speed opto output becomes active (turns on). When the speed is greater than the Level 1 Output SET SPEED parameter, the Opto Output becomes active. This is useful when another machine must not start or stop until the motor exceeds a predetermined speed.</p>	Condition	Description	Ready -	Active when power is applied and no faults are present.	Zero Speed -	Active when motor RPM is below the value of the Level 1 Output “Zero SPD Set Pt” parameter.	At Speed -	Active when output speed is within the speed range defined by the Level 1 Output “At Speed Band” parameter.	Note: In the torque command mode, the At Speed opto output is always in the “OFF” state.		Overload -	Active during an Overload fault caused by a time out when output current is greater than Rated Current.	Keypad Control -	Active when control is in Local keypad control.	At Set Speed -	Active when output speed is at or above the Level 1 Output “Set Speed” parameter.	Fault -	Active when a fault condition is present.	Following ERR -	Active when the motor speed is outside the user specified tolerance band defined by the At Speed Band parameter.	Motor Direction -	Active High when REV direction command received. Active Low when FWD direction command received.	Drive On -	Active when control is “Ready” (has reached excitation level and capable of producing torque).	CMD Direction -	Active at all times. Logical output state indicates Forward or Reverse direction. High=FWD, Low=REV.	At Position -	Active during a positioning command when control is within the position band parameter tolerance.	Over Temp Warn -	Active when control heat sink is within 3°C of Int Overtemp.	Process Error -	Active when process feedback signal is outside the range specified by the Level 2 Process Control block, AT Setpoint Band parameter. Turns off when process feedback error is eliminated.	Drive Run -	Active when drive is Ready, Enabled, Speed or Torque command received with FWD/REV direction issued.	Serial -	Active when drive is in the Serial mode.
Condition	Description																																					
Ready -	Active when power is applied and no faults are present.																																					
Zero Speed -	Active when motor RPM is below the value of the Level 1 Output “Zero SPD Set Pt” parameter.																																					
At Speed -	Active when output speed is within the speed range defined by the Level 1 Output “At Speed Band” parameter.																																					
Note: In the torque command mode, the At Speed opto output is always in the “OFF” state.																																						
Overload -	Active during an Overload fault caused by a time out when output current is greater than Rated Current.																																					
Keypad Control -	Active when control is in Local keypad control.																																					
At Set Speed -	Active when output speed is at or above the Level 1 Output “Set Speed” parameter.																																					
Fault -	Active when a fault condition is present.																																					
Following ERR -	Active when the motor speed is outside the user specified tolerance band defined by the At Speed Band parameter.																																					
Motor Direction -	Active High when REV direction command received. Active Low when FWD direction command received.																																					
Drive On -	Active when control is “Ready” (has reached excitation level and capable of producing torque).																																					
CMD Direction -	Active at all times. Logical output state indicates Forward or Reverse direction. High=FWD, Low=REV.																																					
At Position -	Active during a positioning command when control is within the position band parameter tolerance.																																					
Over Temp Warn -	Active when control heat sink is within 3°C of Int Overtemp.																																					
Process Error -	Active when process feedback signal is outside the range specified by the Level 2 Process Control block, AT Setpoint Band parameter. Turns off when process feedback error is eliminated.																																					
Drive Run -	Active when drive is Ready, Enabled, Speed or Torque command received with FWD/REV direction issued.																																					
Serial -	Active when drive is in the Serial mode.																																					

**Table 4-2 Level 1 Parameter Block Definitions - Continued**

Block Title	Parameter	Description																																																		
OUTPUT (Continued)	Analog Output #1 and #2	<p>Two Analog 0-5VDC linear outputs may be configured to represent any of the following conditions:</p> <table border="0"> <thead> <tr> <th data-bbox="667 338 808 365"><b>Condition</b></th> <th data-bbox="841 338 982 365"><b>Description</b></th> </tr> </thead> <tbody> <tr> <td data-bbox="667 369 808 396">ABS Speed -</td> <td data-bbox="841 369 1533 422">Represents the absolute motor speed where 0VDC = 0 RPM and +5VDC = MAX RPM.</td> </tr> <tr> <td data-bbox="667 426 808 453">ABS Torque -</td> <td data-bbox="841 426 1468 478">Represents the absolute value of torque where +5VDC = Torque at CURRENT LIMIT and 0VDC=0 Torque.</td> </tr> <tr> <td data-bbox="667 483 808 510">Speed Command -</td> <td data-bbox="841 483 1511 535">Represents the absolute value of commanded speed where +5VDC = MAX RPM and 0VDC=0 RPM</td> </tr> <tr> <td data-bbox="667 539 808 567">PWM Voltage -</td> <td data-bbox="841 539 1365 592">Represents the amplitude of PWM voltage where +5VDC = MAX AC Voltage.</td> </tr> <tr> <td data-bbox="667 596 808 623">Flux Current -</td> <td data-bbox="841 596 1398 623">Flux Current Feedback. Useful with CMD Flux CUR.</td> </tr> <tr> <td data-bbox="667 627 808 655">CMD Flux CUR -</td> <td data-bbox="841 627 1133 655">Commanded Flux Current.</td> </tr> <tr> <td data-bbox="667 659 808 686">Load Current -</td> <td data-bbox="841 659 1528 711">Load current feedback is 2.5V centered, 5V = maximum peak positive load current, 0V = maximum peak negative load current.</td> </tr> <tr> <td data-bbox="667 716 808 743">CMD Load Current -</td> <td data-bbox="841 716 1560 768">Commanded load current 2.5V centered, 5V = maximum peak positive load current, 0V = maximum peak negative load current.</td> </tr> <tr> <td data-bbox="667 772 808 800">Motor Current -</td> <td data-bbox="841 772 1544 825">Amplitude of continuous current including motor excitation current. 2.5V = rated Current, 0VDC=0 Current and 5VDC=Peak Current.</td> </tr> <tr> <td data-bbox="667 829 808 856">Load Component -</td> <td data-bbox="841 829 1500 882">Amplitude of load current not including the motor excitation current. 2.5V = rated Current, 0VDC=MAG Current and 5VDC=Peak Current.</td> </tr> <tr> <td data-bbox="667 886 808 913">Quad Voltage -</td> <td data-bbox="841 886 1539 913">Load controller output. Useful when diagnosing control problems.</td> </tr> <tr> <td data-bbox="667 917 808 945">Direct Voltage -</td> <td data-bbox="841 917 1068 945">Flux controller output.</td> </tr> <tr> <td data-bbox="667 949 808 976">AC Voltage -</td> <td data-bbox="841 949 1539 1001">PWM control voltage which is proportional to AC line to line motor terminal voltage. 2.5V centered.</td> </tr> <tr> <td data-bbox="667 1005 808 1033">Bus Voltage -</td> <td data-bbox="841 1005 1003 1033">5V = 1000VDC.</td> </tr> <tr> <td data-bbox="667 1037 808 1064">Torque -</td> <td data-bbox="841 1037 1528 1089">Bipolar torque output. 2.5V centered, 5V = Max Positive Torque, 0V = Max negative torque.</td> </tr> <tr> <td data-bbox="667 1094 808 1121">Power -</td> <td data-bbox="841 1094 1560 1146">Bipolar power output. 2.5V = Zero Power, 0V = negative rated peak power, +5V = Positive rated peak power.</td> </tr> <tr> <td data-bbox="667 1150 808 1178">Velocity -</td> <td data-bbox="841 1150 1479 1203">Represents motor speed scaled to 0V = negative max RPM, +2.5V = Zero Speed, +5V = positive max RPM.</td> </tr> <tr> <td data-bbox="667 1207 808 1234">Overload -</td> <td data-bbox="841 1207 1442 1234">(Accumulated current)<sup>2</sup> x (time), Overload occurs at +5V.</td> </tr> <tr> <td data-bbox="667 1239 808 1266">PH 2 Current -</td> <td data-bbox="841 1239 1533 1291">Sampled AC phase 2 motor current. 2.5V = zero amps, 0V = negative rated peak amps, +5V = positive rated peak amps.</td> </tr> <tr> <td data-bbox="667 1295 808 1323">PH 3 Current -</td> <td data-bbox="841 1295 1533 1348">Sampled AC phase 3 motor current. 2.5V = zero amps, 0V = negative rated peak amps, +5V = positive rated peak amps.</td> </tr> <tr> <td data-bbox="667 1352 808 1379">Process Feedback -</td> <td data-bbox="841 1352 1560 1404">Represents the selected Process Feedback scaled input. 2.5V centered, 5V = maximum positive feedback, 0V = maximum negative feedback.</td> </tr> <tr> <td data-bbox="667 1409 808 1436">Position -</td> <td data-bbox="841 1409 1523 1461">Position within a single revolution +5V = 1 Complete Revolution. The counter is reset to 0 each revolution.</td> </tr> <tr> <td data-bbox="667 1465 808 1493">Setpoint Command -</td> <td data-bbox="841 1465 1507 1539">Represents the selected Setpoint Command scaled. 2.5V centered, 5V = maximum positive setpoint command, 0V = maximum negative setpoint command.</td> </tr> <tr> <td data-bbox="667 1543 808 1570">Serial -</td> <td data-bbox="841 1543 1495 1596">0-5VDC level that represents a value programmed by a serial command.</td> </tr> </tbody> </table> <p data-bbox="396 1606 613 1659">Analog Scale #1 &amp; #2</p> <p data-bbox="623 1606 1559 1659">Scale factor for the Analog Output voltage. Useful to set the zero value or full scale range for external meters.</p> <p data-bbox="396 1669 613 1722">Position Band</p> <p data-bbox="623 1669 1559 1722">Sets the acceptable range in digital counts (pulses) at which the AT Position Opto becomes active (turns on).</p>	<b>Condition</b>	<b>Description</b>	ABS Speed -	Represents the absolute motor speed where 0VDC = 0 RPM and +5VDC = MAX RPM.	ABS Torque -	Represents the absolute value of torque where +5VDC = Torque at CURRENT LIMIT and 0VDC=0 Torque.	Speed Command -	Represents the absolute value of commanded speed where +5VDC = MAX RPM and 0VDC=0 RPM	PWM Voltage -	Represents the amplitude of PWM voltage where +5VDC = MAX AC Voltage.	Flux Current -	Flux Current Feedback. Useful with CMD Flux CUR.	CMD Flux CUR -	Commanded Flux Current.	Load Current -	Load current feedback is 2.5V centered, 5V = maximum peak positive load current, 0V = maximum peak negative load current.	CMD Load Current -	Commanded load current 2.5V centered, 5V = maximum peak positive load current, 0V = maximum peak negative load current.	Motor Current -	Amplitude of continuous current including motor excitation current. 2.5V = rated Current, 0VDC=0 Current and 5VDC=Peak Current.	Load Component -	Amplitude of load current not including the motor excitation current. 2.5V = rated Current, 0VDC=MAG Current and 5VDC=Peak Current.	Quad Voltage -	Load controller output. Useful when diagnosing control problems.	Direct Voltage -	Flux controller output.	AC Voltage -	PWM control voltage which is proportional to AC line to line motor terminal voltage. 2.5V centered.	Bus Voltage -	5V = 1000VDC.	Torque -	Bipolar torque output. 2.5V centered, 5V = Max Positive Torque, 0V = Max negative torque.	Power -	Bipolar power output. 2.5V = Zero Power, 0V = negative rated peak power, +5V = Positive rated peak power.	Velocity -	Represents motor speed scaled to 0V = negative max RPM, +2.5V = Zero Speed, +5V = positive max RPM.	Overload -	(Accumulated current) <sup>2</sup> x (time), Overload occurs at +5V.	PH 2 Current -	Sampled AC phase 2 motor current. 2.5V = zero amps, 0V = negative rated peak amps, +5V = positive rated peak amps.	PH 3 Current -	Sampled AC phase 3 motor current. 2.5V = zero amps, 0V = negative rated peak amps, +5V = positive rated peak amps.	Process Feedback -	Represents the selected Process Feedback scaled input. 2.5V centered, 5V = maximum positive feedback, 0V = maximum negative feedback.	Position -	Position within a single revolution +5V = 1 Complete Revolution. The counter is reset to 0 each revolution.	Setpoint Command -	Represents the selected Setpoint Command scaled. 2.5V centered, 5V = maximum positive setpoint command, 0V = maximum negative setpoint command.	Serial -	0-5VDC level that represents a value programmed by a serial command.
<b>Condition</b>	<b>Description</b>																																																			
ABS Speed -	Represents the absolute motor speed where 0VDC = 0 RPM and +5VDC = MAX RPM.																																																			
ABS Torque -	Represents the absolute value of torque where +5VDC = Torque at CURRENT LIMIT and 0VDC=0 Torque.																																																			
Speed Command -	Represents the absolute value of commanded speed where +5VDC = MAX RPM and 0VDC=0 RPM																																																			
PWM Voltage -	Represents the amplitude of PWM voltage where +5VDC = MAX AC Voltage.																																																			
Flux Current -	Flux Current Feedback. Useful with CMD Flux CUR.																																																			
CMD Flux CUR -	Commanded Flux Current.																																																			
Load Current -	Load current feedback is 2.5V centered, 5V = maximum peak positive load current, 0V = maximum peak negative load current.																																																			
CMD Load Current -	Commanded load current 2.5V centered, 5V = maximum peak positive load current, 0V = maximum peak negative load current.																																																			
Motor Current -	Amplitude of continuous current including motor excitation current. 2.5V = rated Current, 0VDC=0 Current and 5VDC=Peak Current.																																																			
Load Component -	Amplitude of load current not including the motor excitation current. 2.5V = rated Current, 0VDC=MAG Current and 5VDC=Peak Current.																																																			
Quad Voltage -	Load controller output. Useful when diagnosing control problems.																																																			
Direct Voltage -	Flux controller output.																																																			
AC Voltage -	PWM control voltage which is proportional to AC line to line motor terminal voltage. 2.5V centered.																																																			
Bus Voltage -	5V = 1000VDC.																																																			
Torque -	Bipolar torque output. 2.5V centered, 5V = Max Positive Torque, 0V = Max negative torque.																																																			
Power -	Bipolar power output. 2.5V = Zero Power, 0V = negative rated peak power, +5V = Positive rated peak power.																																																			
Velocity -	Represents motor speed scaled to 0V = negative max RPM, +2.5V = Zero Speed, +5V = positive max RPM.																																																			
Overload -	(Accumulated current) <sup>2</sup> x (time), Overload occurs at +5V.																																																			
PH 2 Current -	Sampled AC phase 2 motor current. 2.5V = zero amps, 0V = negative rated peak amps, +5V = positive rated peak amps.																																																			
PH 3 Current -	Sampled AC phase 3 motor current. 2.5V = zero amps, 0V = negative rated peak amps, +5V = positive rated peak amps.																																																			
Process Feedback -	Represents the selected Process Feedback scaled input. 2.5V centered, 5V = maximum positive feedback, 0V = maximum negative feedback.																																																			
Position -	Position within a single revolution +5V = 1 Complete Revolution. The counter is reset to 0 each revolution.																																																			
Setpoint Command -	Represents the selected Setpoint Command scaled. 2.5V centered, 5V = maximum positive setpoint command, 0V = maximum negative setpoint command.																																																			
Serial -	0-5VDC level that represents a value programmed by a serial command.																																																			



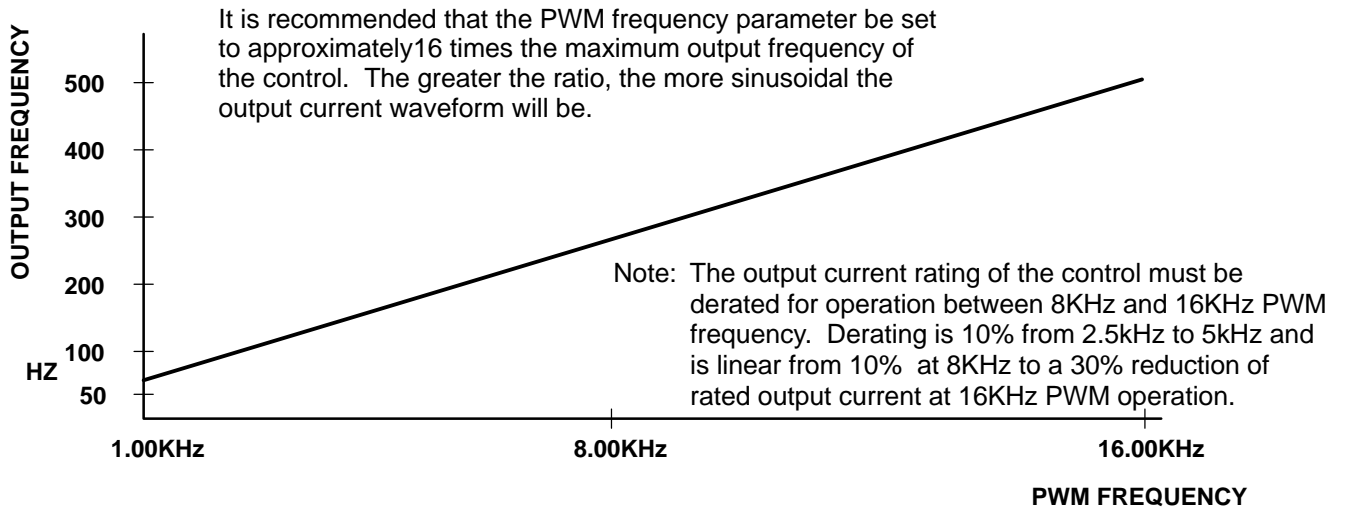
**Table 4-2 Level 1 Parameter Block Definitions - Continued**

<b>Block Title</b>	<b>Parameter</b>	<b>Description</b>
Brushless Control	Resolver Align	A numerical alignment value. The autotune procedure aligns the motor and resolver positions. 22.3 degrees is correct for all Baldor BSM motors.
	Speed Filter	The number of input samples taken by the control microprocessor over which to filter and determine the resolver speed. It is automatically set to suit the resolver resolution. The preset filter may be reduced to obtain smoother slow speed operation. The greater the number, the more filtered the signal becomes and the bandwidth is also reduced.
	Feedback Align	Sets the electrical direction of rotation of the resolver. May be set to forward or reverse to match the motor rotation.
	Current Prop Gain	Sets the current loop proportional gain.
	Current Int Gain	Sets the current loop integral gain.
	Speed Prop Gain	Sets the speed (velocity) loop proportional gain.
	Speed Int Gain	Sets the speed (velocity) loop integral gain.
	Speed Diff Gain	Sets the speed (velocity) loop differential gain.
	Position Gain	Sets the position loop proportional gain.
LEVEL 2 BLOCK		ENTERS LEVEL 2 MENU

**Table 4-3 Level 2 Parameter Block Definitions**

Block Title	Parameter	Description
OUTPUT LIMITS	Operating Zone	Sets the PWM operating zone to Standard 2.5KHz or Quiet 8.0KHz output carrier frequency. Two output power modes are also selectable: Constant Torque and Variable Torque. Constant Torque allows 170 - 200% for 3 seconds overload or 150% for 60 seconds overload. Variable Torque allows 115% peak overload for 60 seconds.
	MIN Output Speed	Sets the minimum motor speed in RPM. During operation, the motor speed will not be allowed to go below this value except for motor starts from 0 RPM or during dynamic braking to a stop or in Process mode.
	MAX Output Speed	Sets the maximum motor speed in RPM.
	PK Current Limit	The maximum output peak current to the motor. Values above 100% of the rated current are available depending upon the operating zone selected.
	PWM Frequency	The frequency that the output transistors are switched. PWM frequency is also referred to as "Carrier" frequency. PWM should be as low as possible to minimize stress on the output transistors and motor windings. It is recommended that the PWM frequency be set to approximately 16 times the maximum output frequency of the control. Ratios less than 16 will result in non-Sinusoidal current waveforms. See Figure 4-3.
	Current Rate Limit	Limits the rate of torque change in response to a torque command.

**Figure 4-3 Maximum Output Frequency vs PWM Frequency**



**Table 4-3 Level 2 Parameter Block Definitions** Continued

Block Title	Parameter	Description
CUSTOM UNITS	Max Decimal Places	The number of decimal places of the Output Rate display on the Keypad display. This value will be automatically reduced for large values. The output rate display is only available if the "Value At Speed" parameter value is non-zero.
	Value At Speed	Sets the desired output rate value per motor RPM. Two numbers are displayed on the keypad display (separated by a slash "/"). The first number (left most) is the value you want the keypad to display at a specific motor speed (second number, right most). A decimal may be inserted into the numbers by placing the flashing cursor over the up/down arrow.
	Value DEC Places	Serial Only. *
	Value Speed REF	Serial Only. *
	Units of Measure	Allows you to specify units of measure to be displayed on the Output Rate display. Use the shift and arrow keys to scroll to the first and successive characters. If the character you want is not displayed, move the flashing cursor over the special up/down character arrow on the left side of the display. Use the up/down arrows and the shift key to scroll through all 9 character sets. Use the ENTER key to save your selection.
	Units of MEAS 2	Serial Only. *
PROTECTION	Overload	Sets the protection mode to Fault (trip off during overload condition) or to Foldback (automatically reduce the output current below the continuous output level) during an overload. Foldback is the choice if continuous operation is desired. Fault will require the control be "Reset" manually or automatically after an overload.
	External Trip	OFF - External Trip is Disabled. ON - External Trip is enabled. If a normally closed contact at J1-16 is opened, an External Trip fault will occur and cause the drive to shut down.
	Local Enable INP	OFF - Ignores J1-8 switched input when in the "LOCAL" mode. ON - Requires J1-8 Enable input to be closed to enable the control when in the "LOCAL" mode.
	Following Error	This parameter determines if the control is to monitor the amount of following error that occurs in an application. Following Error is the programmable tolerance for the AT Speed Opto output as defined by the Level 1 Output block, AT Speed Band parameter. Operation outside the speed range will cause a fault and the drive will shut down.

\* Note: Serial Commands. When using the serial command option, the "Value AT Speed", "Value DEC Places", and "Value Speed REF" parameters must be set. The Value AT Speed parameter sets the desired output rate per increment of motor speed. The Value DEC Places sets the desired number of decimal places of the Value AT Speed number. The Value Speed REF sets the increment of motor speed for the desired output rate.

The Units of Measure parameter sets the two left-most characters of the custom units display while the Units of MEAS 2 parameter sets the two right most characters. For example, if "ABCD" is the custom units, "AB" is set in the Level 2 Custom Units block, Units of Measure parameter and "CD" is set in the Level 2 Custom Units block, Units of MEAS 2 parameter.

Note: Custom Display Units. The output rate display is only available if the Value AT Speed parameter has been changed from a value of 0 (zero). To access the Output Rate display, use the DISP key to scroll to the Output Rate display.

**⚠ Caution:** If an automatic restart of the motor control could cause injury to personnel, the automatic restart feature should be disabled by changing the Level 2 Miscellaneous block, Restart Auto/Man parameter to manual.

**Table 4-3 Level 2 Parameter Block Definitions** Continued

Block Title	Parameter	Description
MISCELLANEOUS	Restart Auto/Man	Manual - If a fault or power loss occurs, the control must be manually reset to resume operation. Automatic - If a fault or power loss occurs, the control will automatically reset to resume operation.
	Restart Fault/Hr	The maximum number of automatic restart attempts before requiring a manual restart. After one hour without reaching the maximum number of faults or if power is turned off and on again, the fault count is reset to zero.
	Restart Delay	The amount of time allowed after a fault condition for an automatic restart to occur. Useful to allow sufficient time to clear a fault before restart is attempted.
	Factory Settings	Restores factory settings for all parameter values. Select YES and press "ENTER" key to restore factory parameter values. The keypad Display will show "Operation Done" then return to "NO" when completed.  Note: When factory settings are reset, the Motor Rated Amps value is reset to 999.9 amps. This Level 2 Motor Data block parameter value must be changed to the correct value (located on the motor rating plate) before attempting to start the drive.
	Homing Speed	In Bipolar and Serial modes, this parameter sets the speed that the motor shaft will rotate to a "Home" position when the orient input switch is closed (J1-11).
	Homing Offset	In Bipolar and Serial modes, this parameter sets the number of digital encoder counts past home at which the motor stop command is issued. Quadrature encoder pulses are 4 times the number of encoder lines per revolution. The recommended minimum number is 100 encoder counts to allow for deceleration distance to allow the motor to stop smoothly.  Note: Homing direction is always forward.
SECURITY CONTROL	Security State	Off - No security Access Code required to change parameter values. Local - Requires security Access Code to be entered before changes can be made using the Keypad. Serial - Requires security Access Code to be entered before changes can be made using the Serial Link. Total - Requires security Access Code to be entered before changes can be made using the Keypad or serial link.  Note: If security is set to Local, Serial or Total you can press PROG and scroll through the parameter values that are programmed but you are not allowed to change them unless you enter the correct access code.
	Access Timeout	The time in seconds the security access remains enabled after leaving the programming mode. If you exit and go back into the program Mode within this time limit, the security Access Code does not have to be re-entered. This timer starts when leaving the Program Mode (by pressing DISP). Access Timeout is operational only in Local security mode.  Note: This feature is not available when using the Serial operating mode or if power is cycled.
	Access Code	A 4 digit number code. Only persons that know the code can change secured Level 1 and Level 2 parameter values. A loss of power to the control will automatically require the secured access code for parameter adjustments.  Note: Please record your access code and store it in a safe place. If you cannot gain entry into parameter values to change a protected parameter, please contact Baldor. Be prepared to give the 5 digit code shown on the lower right side of the Keypad Display at the Security Control Access Code parameter prompt.

**Table 4-3 Level 2 Parameter Block Definitions** Continued

Block Title	Parameter	Description												
MOTOR DATA	Motor Rated Amps	The full load motor current (listed on the motor nameplate). If the motor current exceeds this value for a period of time, an Overload fault will occur.												
	Motor Poles	The number of motor poles. Factory setting is 4 poles. The values shown here are for standard Baldor BSM motors. <table border="0" style="margin-left: 20px;"> <tr> <td style="text-align: left;"><b>MOTOR</b></td> <td style="text-align: center;"><b>NUMBER OF POLES</b></td> </tr> <tr> <td>BSM63, BSM80</td> <td style="text-align: center;">4</td> </tr> <tr> <td>BSM90, BSM100</td> <td style="text-align: center;">8</td> </tr> <tr> <td>BSM4F, BSM6F, BSM8F</td> <td style="text-align: center;">8</td> </tr> <tr> <td>BSM2R, BSM3R, BSM4R</td> <td style="text-align: center;">4</td> </tr> <tr> <td>BSM6R</td> <td style="text-align: center;">6</td> </tr> </table>	<b>MOTOR</b>	<b>NUMBER OF POLES</b>	BSM63, BSM80	4	BSM90, BSM100	8	BSM4F, BSM6F, BSM8F	8	BSM2R, BSM3R, BSM4R	4	BSM6R	6
	<b>MOTOR</b>	<b>NUMBER OF POLES</b>												
	BSM63, BSM80	4												
	BSM90, BSM100	8												
BSM4F, BSM6F, BSM8F	8													
BSM2R, BSM3R, BSM4R	4													
BSM6R	6													
Resolver Speed	The resolver speed. All standard BSM motors use 1 speed resolvers.													
CALC Presets	Loads operating values into memory. These values are based on information programmed into the Level 2 Output Limits and Motor Data parameter values. CALC Presets must be run before Autotuning or manually tuning the drive.													
BRAKE ADJUST	Resistor Ohms	The dynamic braking resistor value in ohms. Refer to dynamic braking manual or call Baldor for additional information.												
	Resistor Watts	The dynamic braking resistor watts rating. Refer to dynamic braking manual or call Baldor for additional information.												
PROCESS CONTROL	Process Feedback	Sets the type of signal used for the process feedback signal.												
	Process Inverse	Causes the process feedback signal to be inverted. Used with reverse acting processes that use a unipolar signal such as 4-20mA. If "ON", 20mA will decrease motor speed and 4mA will increase motor speed.												
	Setpoint Source	Sets the source input signal to which the process feedback will be compared. If "Setpoint CMD" is selected, the fixed value of the set point is entered in the Setpoint Command parameter value.												
	Setpoint Command	Sets the value of the setpoint the control will try to maintain by adjusting motor speed. This is only used when the Setpoint Source is a fixed value "Setpoint CMD" under Setpoint Source.												
	Set PT ADJ Limit	Sets the maximum speed correction value to be applied to the motor (in response to the maximum feedback setpoint error). For example, if the max motor speed is 1750 RPM, the setpoint feedback error is 100% and the setpoint adjustment limit is 10%, the maximum speed the motor will run in response to the setpoint feedback error is $\pm 175$ RPM. If at the process setpoint, the motor speed is 1500 RPM, the maximum speed adj limits is then 1325 to 1675 RPM.												
	Process ERR TOL	Sets the width of the comparison band (% of setpoint) with which the process input is compared. The result is that if the process input is within the comparison band the corresponding Opto Output will become active.												
	Process PROP Gain	Sets the PID loop proportional gain. This determines how much adjustment to motor speed (within the Set PT ADJ Limit) is made to move the analog input to the setpoint.												
	Process INT Gain	Sets the PID loop Integral gain. This determines how quickly the motor speed is adjusted to correct long term error.												
	Process DIFF Gain	Sets the PID loop differential gain. This determines how much adjustment to motor speed (within the Set PT ADJ Limit) is made for transient error.												

**Table 4-3 Level 2 Parameter Block Definitions** Continued

Block Title	Parameter	Description
PROCESS CONTROL (Continued)	Follow I:O Ratio	<p>Sets the ratio of the Master to the Follower in Master/Follower configurations. Requires the Master Pulse Reference/ Isolated Pulse Follower expansion board. For example, the master encoder you want to follow is a 1024 count encoder. The follower motor you wish to control also has a 1024 count encoder on it. If you wish the follower to run twice the speed of the master, a 1:2 ratio is entered. Fractional ratios such as 0.5:1 are entered as 1:2. Ratio limits are 65,535:1 to 1:20.</p> <p>Note: The Master Encoder parameter must be defined if a value is entered in the Follow I:O Ratio parameter.</p> <p>Note: When using Serial Communications to operate the control, this value is the MASTER portion of the ratio. The FOLLOWER portion of the ratio is set in the Follow I:O Out parameter.</p>
	Follow I:O Out	<p>This parameter is visible for use only when Serial Communication is used to operate the control. A Master Pulse Reference/ Isolated Pulse Follower expansion board is required. This parameter represents the FOLLOWER portion of the ratio. The MASTER portion of the ratio is set in the Follow I:O Ratio parameter.</p>
	Master Encoder	<p>Only used if an optional Master Pulse Reference/Isolated Pulse Follower expansion board is installed. Defines the number of pulses per revolution of the master encoder. Only used for follower drives.</p>
COMMUNICATIONS	Protocol	<p>Sets the type of communication the control is to use, RS-232 ASCII, RS-485 ASCII, RS-232 BBP or RS-485 BBP protocol.</p>
	Baud Rate	<p>Sets the speed at which communication is to occur.</p>
	Drive Address	<p>Sets the address of the control for communication with other microprocessors.</p>
AUTO TUNING		<p>The Auto Tune procedure is used to automatically measure and calculate certain parameter values. Occasionally, the Auto Tune procedure cannot be run due to various circumstances such as the load cannot be uncoupled from the motor. The control can be manually tuned by entering the parameter values based on calculations you have made. Refer to "Manually Tuning the Control" in the Troubleshooting section of this manual.</p>
	CALC Presets	<p>This procedure loads preset values into memory that are required to perform Auto Tune. Always run CALC Presets as the first step of Auto Tune.</p>
	CMD Offset Trim	<p>This procedure trims offset voltage at the differential analog input at J1A-4 and J1A-5.</p>
	CUR Loop COMP	<p>Measures current response while running motor at one half the rated motor current.</p>
	Resolver Align	<p>This procedure checks the electrical alignment of the resolver with respect to the motor stator. This test locks the motor rotor into a reference position and proceeds to check are re-adjust if necessary.</p>
SPD CNTRLR CALC	<p>Should be performed with the load coupled to the motor shaft. Sets the motor current to acceleration ratio, Integral gain and Differential gain values. If done under no load, the Integral gain will be too large for high inertia loads if the PK Current Limit is set too low. If the control is too responsive when the motor is loaded, adjust the PK Current Limit parameter to a greater value and repeat this test.</p>	
LEVEL 1 BLOCK		<p>ENTERS LEVEL 1 MENU</p>



# Section 5 Troubleshooting

## Overview

The Baldor Series 23H Control requires very little maintenance and should provide years of trouble free operation when installed and applied correctly. Occasional visual inspection and cleaning should be considered to ensure tight wiring connections and to remove dust, dirt, or foreign debris which can reduce heat dissipation.


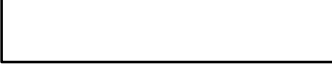

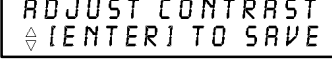

Operational failures called "Faults" will be displayed on the Keypad Display as they occur. A comprehensive list of these faults, their meaning and how to access the fault log and diagnostic information is provided later in this section. Troubleshooting information is provided later in this section.

Before attempting to service this equipment, all input power must be removed from the control to avoid the possibility of electrical shock. The servicing of this equipment should be handled by a qualified electrical service technician experienced in the area of high power electronics.

It is important to familiarize yourself with the following information before attempting any troubleshooting or service of the control. Most troubleshooting can be performed using only a digital voltmeter having an input impedance exceeding 1 megohm. In some cases, an oscilloscope with 5 MHz minimum bandwidth may be useful. Before consulting the factory, check that all power and control wiring is correct and installed per the recommendations given in this manual.

## No Keypad Display - Display Contrast Adjustment

At power up, the display may be blank if the contrast is improperly set. Use the following procedure to adjust the display contrast.






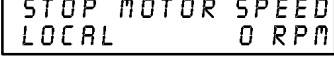
Action	Description	Display	Comments
Apply Power	No visible display.		Display mode.
Press DISP key	Ensures control in Display mode.		
Press SHIFT key 2 times	Allows display contrast adjustment.		
Press ▲ or ▼ key	Adjusts display contrast (intensity).		
Press ENTER key	Saves display contrast adjustment level and exits to display mode.		







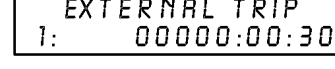
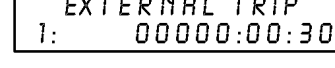
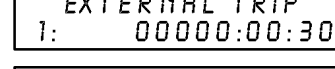
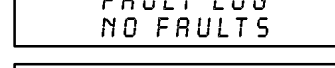
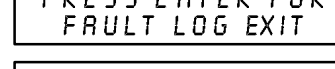
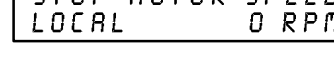
## How to Access Diagnostic Information

Action	Description	Display	Comments
Apply Power		<pre>BALDOR MOTORS &amp; DRIVES</pre>	Logo display for 5 seconds.
	Display mode showing motor speed.	<pre>STOP MOTOR SPEED LOCAL 0 RPM</pre>	No faults present. Local keypad mode. If in remote/serial mode, disable drive then press local for this display.
Press DISP key 6 times	Scroll to Diagnostic Information screen	<pre>PRESS ENTER FOR DIAGNOSTIC INFO</pre>	Diagnostic Access screen.
Press ENTER key	Access diagnostic information.	<pre>STOP SPEED REF LOCAL 0 RPM</pre>	First Diagnostic Information screen.
Press DISP key	Display showing control temperature.	<pre>STOP CONTROL TEMP LOCAL 0.0° C</pre>	
Press DISP key	Display showing bus voltage.	<pre>STOP BUS VOLTAGE LOCAL XXXV</pre>	
Press DISP key	Display showing % overload current remaining.	<pre>STOP OVRLD LEFT LOCAL 100.00%</pre>	
Press DISP key	Display showing real time opto input & output states. (0=Open, 1=Closed).	<pre>DIGITAL I/O 00000000 0000</pre>	Opto Inputs states (Left); Opto Outputs states (Right).
Press DISP key	Display showing actual drive running time.	<pre>TIME FROM PUR UP 0000000.01.43</pre>	HR.MIN.SEC format.
Press DISP key	Display showing operating zone, voltage and control type.	<pre>QUIET VAR TO XXXV ENCODERLESS</pre>	
Press DISP key	Display showing continuous amps; PK amps rating; amps/volt scale of feedback, power base ID.	<pre>XXA XX APK X.XX A/V ID:XXX</pre>	ID is a hexadecimal value.
Press DISP key	Display showing which Group1 or 2 expansion boards are installed and recognized.	<pre>G1 NOT INSTALLED G2 NOT INSTALLED</pre>	In this case, no expansion boards are installed.
Press DISP key	Display showing software version and revision installed in the control.	<pre>SOFTWARE VERSION XXX-X.XX</pre>	
Press DISP key	Displays exit choice.	<pre>PRESS ENTER FOR DIAGNOSTIC EXIT</pre>	Press ENTER to exit diagnostic information.

**How to Access the Fault Log** When a fault condition occurs, motor operation stops and a fault code is displayed on the Keypad display. The control keeps a log of up to the last 31 faults. If more than 31 faults have occurred, the oldest fault will be deleted from the fault log to make room for the newest fault. To access the fault log use the following procedure:

Action	Description	Display	Comments
Apply Power			Logo display for 5 seconds.
	Display mode showing output frequency		Display mode.
Press DISP key 5 times	Use DISP key to scroll to the Fault Log entry point.		
Press ENTER key	Display first fault type and time fault occurred.		Typical display.
Press ▲ key	Scroll through fault messages.		If no messages, the fault log exit choice is displayed.
Press ENTER key	Return to display mode.		Display mode. Stop key LED is on.

**How to Clear the Fault Log** Use the following procedure to clear the fault log and reset the internal clock.

Action	Description	Display	Comments
Apply Power			Logo display for 5 seconds.
	Display mode showing output frequency.		Display mode.
Press DISP key	Press DISP to scroll to the Fault Log entry point.		
Press ENTER key	Displays most recent message.		1 = most recent fault 2 = second most recent fault, etc.
Press SHIFT key			
Press RESET key			
Press SHIFT key			
Press ENTER key	Fault log is cleared.		No faults in fault log and the internal clock is reset.
Press ▲ or ▼ key	Scroll Fault Log Exit.		
Press ENTER key	Return to display mode.		

**Table 5-1 Fault Messages**

FAULT MESSAGE	DESCRIPTION
Current Sens FLT	Defective phase current sensor or open circuit detected between control board and current sensor.
DC Bus High	Bus over voltage condition occurred.
DC Bus Low	Bus under voltage condition occurred.
External Trip	An open circuit on J1-16 typically indicating an external over temperature condition occurred.
GND FLT	Low impedance path detected between an output phase and ground.
INT Over-Temp	Temperature of control heatsink exceeded safe level.
Invalid Base ID	Control does not recognize power base ID.
Inverter Base ID	Control board installed on power base without current feedback.
Line Regen FLT	Only applies to Series 21H and 22H Line Regen controls.
Logic Supply FLT	Logic power supply not working properly.
Lost User Data	Battery backed RAM parameters have been lost or corrupted. When fault cleared (Reset), the control should reset to factory preset values.
Low INIT Bus V	Insufficient bus voltage on startup.
Memory Error	EEPROM error occurred. Contact Baldor.
New Base ID	Control board sensed a different power base since last time it was powered up.
No Faults	Fault log is empty.
No EXB Installed	Programmed operating parameter requires an expansion board that is not installed or is not recognized.
Over Current FLT	Instantaneous over current condition detected by bus current sensor.
Overload - 1 min	Output current exceeded 1 minute rating.
Overload - 3 sec	Output current exceeded 3 second rating.
Over speed	Motor RPM exceeded 110% of programmed MAX Motor Speed.
µP Reset	Power cycled before the residual Bus voltage reached 0VDC.
PWR Base FLT	Desaturation of power device occurred or bus current threshold was exceeded. (On B2 size controls, a desat error can indicate any of the following: low line impedance, brake transistor failure or excessive internal temperature at the output transistors.)
Regen R PWR FLT	Regen power exceeded DB resistor rating.
User Fault Text	Custom software operating fault occurred.
Co-Processor Fault	Co-Processor hardware fault occurred. Contact Baldor.

## Resolver Troubleshooting

SYMPTOM	POSSIBLE CAUSE	CORRECTIVE ACTION
Continuous Overspeed Fault displayed on keypad.	Resolver wiring connection is disconnected, a wire broken or miswired. Missing or miswired shield.	Inspect and repair the resolver wiring. Terminate shield properly @ J1-28
Intermittent Overspeed Fault displayed on keypad.	Resolver wiring connection is intermittent. Missing or miswired shield. Resolver signal is outside of specification.	Inspect and repair the resolver wiring. Terminate shield properly @ J1-28. The resolver output Sine and Cosine maximum voltage must be 2VAC RMS $\pm 10\%$ at the J1 terminal strip. This high frequency voltage (5kHz) can only be measured with a Fluke 87 or equivalent meter or an oscilloscope. Rotate the resolver to find the max voltage.
When commanded to run, the motor will not rotate and the keypad current display is in excess of the motor rated amps. Resolver coupling has failed.	The resolver has failed or is not connected properly. Resolver is not aligned properly.	Verify the resolver is connected and wired properly. Disable control and rotate motor by hand. If the position display in the keypad diagnostic menu shows a position change, then the resolver is probably working. Run the auto tune test to align the resolver.  Replace resolver coupling.

The fourth auto-tuning step (Resolver Align) can be used to effectively troubleshoot the system. The purpose of the test procedure is to adjust the electrical alignment of the resolver with respect to the motor stator. There are four steps that the auto tuning procedure performs:

1. This test initially displays the calculated number of counts per motor pole pair. For example, if using a BSM4F motor, with the MOTOR POLES parameter set to 8 and a standard 1 speed resolver, the initial keypad display will be 1024. The equation is:  $[4096 \text{ counts} / (8 \text{ motor poles}/2) = 1024]$ .

**HELPFUL HINT:** If the resolver speed (or poles) is unknown, a simple test can be useful to determine the number of resolver speed. Temporarily set the resolver speed parameter to 10. With the resolver wired to the motor control, apply power to the motor control. Go to the diagnostic menu and select the position display. Rotate the motor shaft by hand until the display indicates approximately 0000:0000. Rotate the motor shaft by hand exactly 1 revolution. If the keypad display shows approximately 4096, the resolver is a 1 speed resolver, approximately 8,192 = 2 speed, approximately 12,288 = 3 speed and 16,192 = 4 speed, etc. in multiples of 4096. When the resolver speed is known, set the resolver speed parameter to the proper number before starting the auto-tune test.

2. The control then locks the motor rotor into a reference position using 50% of motor rated current and then proceeds to check and re-adjust if necessary, the factory setting of the resolver alignment parameter. This is similar to setting a clock to the local time. This parameter is scaled in degrees.
3. From the reference position, the control slowly rotates the motor through a 360° electrical cycle of current using 50% motor rated current. The number of counts from the resolver is compared against the number calculated in step 1. From the above example with the BSM4F motor, if the control receives approximately 1024 counts ( $\pm 10\%$ ) from the resolver, then the test will pass. This portion of the test will take approximately 6 to 12 seconds.

**HELPFUL HINT:** If the motor poles are unknown, this test can be useful to determine the number of motor poles. A 2 pole motor will mechanically rotate the motor shaft 360°, a 4 pole motor will rotate 180°, a 6 pole motor will rotate 120°, a 8 pole motor will rotate 90°. Observing the mechanical rotation will indicate the number of motor poles.

4. As part of step 3, the resolver rotation is determined and the feedback alignment parameter is adjusted to the appropriate direction, FWD or REV.

**Table 5-2 Troubleshooting**

INDICATION	POSSIBLE CAUSE	CORRECTIVE ACTION
No Display	Lack of input voltage.	Check input power for proper voltage. Verify fuses are good (or breaker is not tripped).
	Loose connections.	Check input power termination. Verify connection of operator keypad.
	Adjust display contrast.	See Adjust Display Contrast in this section.
Current Sense FLT	Open circuit between control board and current sensor.	Check connections between control board and current sensor.
	Defective current sensor.	Replace current sensor.
DC Bus High	Excessive dynamic braking power.	Increase the DECEL time. Check dynamic brake watt and resistance parameter values. Add optional dynamic braking hardware.
	Dynamic brake wiring problem.	Check dynamic brake hardware wiring.
	Input voltage too high.	Verify proper AC line voltage. Use step down isolation transformer if needed. Use line reactor to minimize spikes.
	Too fast a Decel rate.	Increase Decel time parameter value.
DC Bus Low	Input voltage too low.	Disconnect dynamic brake hardware and repeat operation. Verify proper AC line voltage. Use step up isolation transformer if needed. Check power line disturbances (sags caused by start up of other equipment). Monitor power line fluctuations with date and time imprint to isolate power problem.
External Trip	Motor ventilation insufficient.	Clean motor air intake and exhaust. Check external blower for operation. Verify motor's internal fan is coupled securely.
	Motor draws excessive current.	Check motor for overloading. Verify proper sizing of control and motor.
	No thermostat connected.	Connect thermostat. Verify connection of all external trip circuits used with thermostat. Disable thermostat input at J1-16 (External Trip Input).
	Poor thermostat connections.	Check thermostat connections.
	External trip parameter incorrect.	Verify connection of external trip circuit at J1-16. Set external trip parameter to "OFF" if no connection made at J1-16.
GND FLT	Improper wiring. Wiring shorted in conduit. Motor winding shorted.	Disconnect wiring between control and motor. Retry test. If GND FLT is cleared, reconnect motor leads and retry the test. Rewire as necessary. Repair motor. If GND FLT remains, contact Baldor.
INT Over-Temp	Drive Overloaded.	Correct motor loading. Verify proper sizing of control and motor.
	Ambient temperature too high.	Relocate control to cooler operating area. Add cooling fans or air conditioner to control cabinet.
	Cooling fans clogged or restricted air path.	Clean fans and air path.

**Table 5-2 Troubleshooting** Continued

INDICATION	POSSIBLE CAUSE	CORRECTIVE ACTION
Invalid Base ID	Control does not recognize HP and Voltage configuration.	Press "RESET" key on keypad. If fault remains, call Baldor.
Inverter Base ID	Power base with no output phase current sensors being used.	Replace power base with one that has output phase current feedback. Contact Baldor.
Logic Supply FLT	Power supply malfunctioned.	Replace logic power supply.
Lost User Data	Battery backed memory failure.	Parameter data was erased. Disconnect power to control and apply power (cycle power). Enter all parameters. Cycle power. If problem persists, contact Baldor.
Low INIT Bus V	Improper AC line voltage.	Disconnect Dynamic Brake hardware and retry test. Check input AC voltage level.
Memory Error	EEPROM memory fault occurred.	Press "RESET" key on keypad. If fault remains, call Baldor.
μP Reset	Power was cycled before Bus voltage reached 0VDC.	Press "RESET" key on keypad. Disconnect power and allow at least 5 minutes for Bus capacitors to discharge before applying power. If fault remains, call Baldor.
Motor has wrong response to Speed Command	Analog input common mode voltage may be excessive.	Connect control input source common to control common to minimize common mode voltage. Maximum common mode voltage at terminals J1-4 and J1-5 is ±15VDC referenced to chassis common.
Motor Will Not Start	Not enough starting torque.	Increase Current Limit setting.
	Motor overloaded.	Check for proper motor loading. Check couplings for binding. Verify proper sizing of control and motor.
	Control not in local mode of operation.	Place control in local mode.
	Motor may be commanded to run below minimum frequency setting.	Increase speed command or lower minimum frequency setting.
	Incorrect Command Select parameter.	Change Command Select parameter to match wiring at J1.
	Incorrect speed command.	Verify control is receiving proper command signal at J1.
Motor Will Not Reach Maximum Speed	Max Output Speed set too low.	Adjust MAX Output Speed parameter value.
	Motor overloaded.	Check for mechanical overload. If unloaded motor shaft does not rotate freely, check motor bearings.
	Improper speed command.	Verify control is set to proper operating mode to receive speed command. Verify control is receiving proper command signal at input terminals. Check velocity loop gains.
	Speed potentiometer failure.	Replace potentiometer.
Motor Will Not Stop Rotation	MIN Output Speed parameter set too high.	Adjust MIN Output Speed parameter value.
	Improper speed command.	Verify control is receiving proper command signal at input terminals. Verify control is set to receive speed command.
	Speed potentiometer failure.	Replace potentiometer.
	Analog input common mode voltage may be excessive.	Connect control input source common to control common to minimize common mode voltage. Maximum common mode voltage at terminals J1-4 and J1-5 is ±15VDC referenced to chassis common.
	Analog offset trim set incorrectly.	Adjust the Level 1 Input block, ANA CMD Offset parameter value to obtain zero speed with a zero value input command.

**Table 5-2 Troubleshooting** Continued

INDICATION	POSSIBLE CAUSE	CORRECTIVE ACTION
New Base ID	Software parameters are not initialized on newly installed control board.	Press "RESET" key on keypad to clear the fault condition. Cycle power (turn power OFF then ON). Reset parameter values to factory settings. Access diagnostics and compare power base ID number to list in Table 5-3 to ensure a match. Re-enter the Parameter Block Values you recorded in the User Settings at the end of this manual. Autotune the control.
No EXB Installed	Parameter incorrectly set.	Change Level 1 Input block, Command Select parameter and Level 2 Process Control block, Process Feedback and Setpoint Source parameters, to selections that do not require an expansion board.
	Need expansion board.	Install the correct expansion board for selected operating mode.
	Incorrect software Revision	Software does not support the revision level of the board installed. Update software.
Over Current FLT	Current Limit parameter set lower than drive rating.	Increase PK Current Limit parameter in the Level 2 Output Limits block, not to exceed drive rating.
	ACCEL/DECEL time too short.	Increase ACCEL/DEC parameters in the Level 1 ACCEL/DECEL Rate block.
	Electrical noise from external DC coils.	Install reverse biased diodes across all external DC relay coils as shown in the Opto Output circuit examples of this manual. See Electrical Noise Considerations in this Section.
	Electrical noise from external AC coils.	Install RC snubbers on all external AC coils. See Electrical Noise Considerations in this Section.
	Excessive load.	Reduce the motor load. Verify proper sizing of control and motor.
	Excessive motor current.	Verify motor leads are properly connected to control. (Motor is phase sensitive, refer to Section 3 for connection information).
Overload - 3 Sec FLT	Peak output current exceeded 3 second rating.	Check PK Current Limit parameter in the Level 2 Output Limits block. Change Overload parameter In the Level 2 Protection block from Fault to Foldback. Check motor for overloading. Increase ACCEL time. Reduce motor load. Verify proper sizing of control and motor.
	Excessive motor current.	Verify motor leads are properly connected to control. (Motor is phase sensitive, refer to Section 3 for connection information).
Overload - 1 Min FLT	Peak output current exceeded 1 minute rating.	Verify Level 2 Motor Data is correct. Check PK Current Limit parameter in the Level 2 Output Limits block. Change Overload parameter In the Level 2 Protection block from Fault to Foldback. Check motor for overloading. Increase ACCEL/DECEL times. Reduce motor load. Verify proper sizing of control and motor.
	Excessive motor current.	Verify motor leads are properly connected to control. (Motor is phase sensitive, refer to Section 3 for connection information).

**Table 5-2 Troubleshooting** Continued

<b>INDICATION</b>	<b>POSSIBLE CAUSE</b>	<b>CORRECTIVE ACTION</b>
Power Module	Power supply failure.	Press "RESET" key on keypad. If fault remains, call Baldor.
PWR Base FLT	Improper ground	Be sure control has separate ground wire to earth ground. Panel grounding or conduit connection is not sufficient.
	Excessive current.	Disconnect motor leads from control and retry test. If fault remains, call Baldor.
	Electrical noise from external DC coils.	Install reverse biased diodes across all external DC relay coils as shown in the Opto Output circuit examples of this manual. See Electrical Noise Considerations in this Section.
	Electrical noise from external AC coils.	Install RC snubbers on all external AC coils. See Electrical Noise Considerations in this Section.
	Excessive load.	Correct motor load. Verify proper sizing of control and motor.
	Excessive power in dynamic brake circuit.	Verify proper Ohm and Watt parameters of DC Injection Braking. Increase decel time. Add optional dynamic braking hardware.
Regen R PWR FLT	Incorrect dynamic brake parameter.	Check Resistor Ohms and Resistor Watts parameters in the Level 2 Brake Adjust block.
	Regen power exceeded dynamic brake resistor rating.	Add optional dynamic braking hardware.
	Input voltage too high.	Verify proper AC line voltage. Use step down transformer if needed. Use line reactor to minimize spikes.
Unknown Fault	Fault occurred but cleared before its source could be identified.	Check AC line for high frequency noise. Check input switch connections and switching noise.
User Fault Text	Fault detected by custom software.	Refer to custom software fault list.
Co-Processor Fault	Fault detected.	Contact Baldor.



**Table 5-3 Power Base ID - Series 23H**

230VAC			460VAC		
Catalog No.	Size	Power Base ID	Catalog No.	Size	Power Base ID
2A03-E	A	823	4A04-E	A	A3D
2A04-E	A	824	4A05-E	A	A41
2A04-W	A	824	4A08-E	A	A3E
2A07-E	A	833	4A11-E	B	A07
2A10-E	A	826	4A11-E	B2	A4A
2A10-W	A	826	4A14-E	B	A42
2A15-E	B2	82D	4A14-E	B2	A4B
2A16-E	B	827	4A15-E	B	A42
2A16-E	B2	82D	4A15-E	B2	A4B
2A22-E	B	828	4A15-ER	C	A10
2A22-E	B2	82E	4A21-E	B2	A4C
2A28-E	B	81A	4A21-EO	C2	A11
2A28-E	B2	82F	4A22-ER	C	8A11
2A30-ER	C	4810	4A27-ER	C2	A12
2A42-E	B2	830	4A30-ER	C	4A0B
2A42-EO	C2	811			
2A45-ER	C	2811			
2A54-ER	C2	81D			
2A55-ER	C	6809			

Note: The Power Base ID number of a control is displayed in a Diagnostic Information screen as a hexadecimal value.

---

## Electrical Noise Considerations

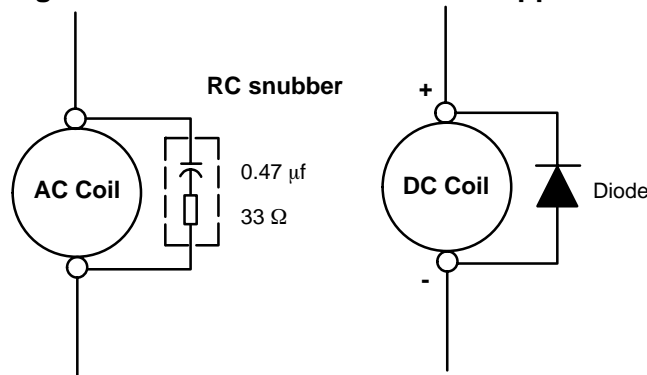
All electronic devices are vulnerable to significant electronic interference signals (commonly called “Electrical Noise”). At the lowest level, noise can cause intermittent operating errors or faults. From a circuit standpoint, 5 or 10 millivolts of noise may cause detrimental operation. For example, analog speed and torque inputs are often scaled at 5 to 10VDC maximum with a typical resolution of one part in 1,000. Thus, noise of only 5 mV represents a substantial error.

At the extreme level, significant noise can cause damage to the drive. Therefore, it is advisable to prevent noise generation and to follow wiring practices that prevent noise generated by other devices from reaching sensitive circuits. In a control, such circuits include inputs for speed, torque, control logic, and speed and position feedback, plus outputs to some indicators and computers.

### Relay and Contactor Coils

Among the most common sources of noise are the coils of contactors and relays. When these highly inductive coil circuits are opened, transient conditions often generate spikes of several hundred volts in the control circuit. These spikes can induce several volts of noise in an adjacent wire that runs parallel to a control-circuit wire. Figure 5-1 illustrates noise suppression for AC and DC relay coils.

**Figure 5-1 AC and DC Coil Noise Suppression**



### Wires between Controls and Motors

Output leads from a typical 460VAC drive controller contain rapid voltage rises created by power semiconductors switching 650V in less than a microsecond, 1,000 to 10,000 times a second. These noise signals can couple into sensitive drive circuits. If shielded pair cable is used, the coupling is reduced by nearly 90%, compared to unshielded cable.

Even input AC power lines contain noise and can induce noise in adjacent wires. In some cases, line reactors may be required.

To prevent induced transient noise in signal wires, all motor leads and AC power lines should be contained in rigid metal conduit, or flexible conduit. Do not place line conductors and load conductors in same conduit. Use one conduit for 3 phase input wires and another conduit for the motor leads. The conduits should be grounded to form a shield to contain the electrical noise within the conduit path. Signal wires - even ones in shielded cable should never be placed in the conduit with motor power wires.

---

## Special Drive Situations

For severe noise situations, it may be necessary to reduce transient voltages in the wires to the motor by adding load reactors. Load reactors are installed between the control and motor.

Reactors are typically 3% reactance and are designed for the frequencies encountered in PWM drives. For maximum benefit, the reactors should be mounted in the drive enclosure with short leads between the control and the reactors.

## Control Enclosures

Motor controls mounted in a grounded enclosure should also be connected to earth ground with a separate conductor to ensure best ground connection. Often grounding the control to the grounded metallic enclosure is not sufficient. Usually painted surfaces and seals prevent solid metallic contact between the control and the panel enclosure. Likewise, conduit should never be used as a ground conductor for motor power wires or signal conductors.

## Special Motor Considerations

Motor frames must also be grounded. As with control enclosures, motors must be grounded directly to the control and plant ground with as short a ground wire as possible. Capacitive coupling within the motor windings produces transient voltages between the motor frame and ground. The severity of these voltages increases with the length of the ground wire. Installations with the motor and control mounted on a common frame, and with heavy ground wires less than 10 ft. long, rarely have a problem caused by these motor-generated transient voltages.

## Analog Signal Wires

Analog signals generally originate from speed and torque controls, plus DC tachometers and process controllers. Reliability is often improved by the following noise reduction techniques:

- Use twisted-pair shielded wires with the shield grounded at the drive end only.
- Route analog signal wires away from power or control wires (all other wiring types).
- Cross power and control wires at right angles (90°) to minimize inductive noise coupling.

## Section 6

# Manual Tuning the Series 23H Control

---

**Manually Tuning the Control** In some applications the drive cannot be accurately auto-tuned. In these cases, it is necessary to calculate the values needed to tune the drive and manually enter these calculated parameter values.

**Current Prop Gain Parameter** This parameter is located in the Level 1, Brushless Control Block. The Current Prop Gain parameter is normally autotuned when motor inductance is not known. Where autotuning can't be used, the proper manual setting for the proportional gain can be calculated by:

$$\text{Current PROP Gain} = \frac{[740 \times L \times (A/V)]}{\text{VAC}}$$

Where:

L = Line to neutral leakage inductance of the motor in mH

VAC = Nominal line volts

A/V = The amps/volt scaling of the current feedback

Motor line to neutral leakage inductance can be obtained either from the motor manufacturer or for WYE connected motors, by measuring the line-to-line inductance and dividing the measured value by two.

The A/V scaling for the controller can be found in the diagnostic information located in the DISPLAY MODE.

For most applications setting the Current Prop Gain parameter to a value of 20 will yield adequate performance.

**Current INT Gain Parameter** This parameter is located in the Level 1, Brushless Control Block. The factory setting is suitable for essentially all systems. **Do not change without factory approval.**

### Speed Prop Gain Parameter

The Speed Prop Gain parameter is located in the Level 1 Brushless Control Block. This gain may be increased or decreased to suit the application. Increasing the Speed Prop Gain parameter will result in faster response, excessive proportional gain will cause overshoot and ringing. Decreasing the Speed Prop Gain parameter will cause slower response and decrease overshoot and ringing caused by excessive proportional gain.

---

## Speed Int Gain Parameter

The Speed Int Gain parameter located in the Level 1 Brushless Control Block may be set to any value from zero to 9.99 Hz. See also, PI Controller later in this section.

Setting the Speed Int Gain parameter to 0Hz removes integral compensation that results in a proportional rate loop. This selection is ideal for systems where overshoot must be avoided and substantial stiffness (ability of the controller to maintain commanded speed despite varying torque loads) isn't required.

Increasing values of the Speed Int Gain parameter increases the low frequency gain and stiffness of the controller, an excessive integral gain setting will cause overshoot for transient speed commands and may lead to oscillation. If the Speed Prop Gain parameter and the Speed Int Gain parameter are set too high, an overshoot condition can also occur.

To manually tune the control, the following procedure is used:

1. Set the speed Int Gain parameter = 0 (remove integral gain).
2. Increase the Speed Prop Gain parameter setting until adequate response to step speed commands is attained.
3. Increase the Speed Int Gain parameter setting to increase the stiffness of the drive.

Note: It is convenient to monitor speed step response with a strip chart recorder or storage oscilloscope connected to J1-6 or -7 with Level 1, Output Block Analog Out #1 or #2 set to ABS SPEED, 0 VDC = zero speed. See Section 3 for a discussion of analog outputs.

## PI Controller

Both the current and rate control loops are of the Proportional plus Integral type. If "E" is defined to be the error signal,

$E = \text{Command} - \text{Feedback}$

then the PI controller operated on "E" as

$$\text{Output} = (K_p * E) + (K_i \int E dt)$$

where  $K_p$  is the proportional gain of the system and  $K_i$  is the integral gain of the system.

The transfer function (output /E) of the controller using 1/s (Laplace Operator) to denote the integral,

$$\text{Output}/E = K_p + K_i / s = K_p (s + K_i/K_p) /s.$$

The second equation shows that the ratio of  $K_i/K_p$  is a frequency in radians/sec. In the Baldor Control, the integral gain has been redefined to be,

$$K_i = (K_i / K_p) / (2\pi) \text{ Hz},$$

and the transfer function is,

$$\text{Output}/E = K_p (s + 2\pi K_i) / s.$$

This sets the integral gain as a frequency in Hz. As a rule of thumb, set this frequency about 1/10 of the bandwidth of the control loop.

The proportional gain sets the open loop gain of the system, the bandwidth (speed of response) of the system. If the system is excessively noisy, it is most likely due to the proportional gain being set too high.

## Section 7

# Specifications, Ratings & Dimensions

---

### Specifications:

Power	0.75 - 37.2kW (1-50 HP) @ 230VAC 0.75 - 186.5kW (1-250 HP) @ 460VAC
Input Frequency	50/60 HZ $\pm$ 5%
Output Voltage	0 to Maximum Input VAC
Output Current	See Ratings Table
Service Factor	1.0
Duty	Continuous
Overload Capacity	Constant Torque Mode: 170-200% for 3 secs 150% for 60 secs Variable Torque Mode: 115% for 60 secs
Speed Command Potentiometer	5k or 10k ohm, 0.5Watt

### Operating Conditions:

Voltage Range: 230 VAC Models 460 VAC Models	180-264 VAC 3 $\phi$ 60 Hz / 180-230 VAC 3 $\phi$ 50 Hz 340-528 VAC 3 $\phi$ 60 Hz / 380-415 VAC 3 $\phi$ 50 Hz
Input Line Impedance:	Size A, B, C, D, E requires 3% Minimum Size B2, C2, D2, F and G requires 1% Minimum
Ambient Operating Temperature:	-10 to +40 °C Derate Output 2% per °C over 40 °C to 55 °C Max
Rated Storage Temperature:	- 30 °C to +65 °C
Enclosure:	NEMA 1: E and EO (suffix) Models NEMA 4X: W (suffix) Models
Humidity:	NEMA 1: 10 to 90% RH Non-Condensing NEMA 4X: To 100% RH
Altitude:	Sea level to 3300 Feet (1000 Meters) Derate 2% per 1000 Feet (303 Meters) above 3300 Feet
Shock:	1G
Vibration:	0.5G at 10Hz to 60Hz

### Resolver Feedback:

Sine & Cosine Inputs	2V <sub>RMS</sub> $\pm$ 10% (Maximum Coupled)
Excitation (Reference Voltage)	4V <sub>RMS</sub> @ 10kHz
Resolver Transformation Ratio	TR = 0.5 only

---

## Keypad Display:

Display	Backlit LCD Alphanumeric 2 Lines x 16 Characters
Keys	12 key membrane with tactile response
Functions	Output status monitoring Digital speed control Parameter setting and display Diagnostic and Fault log display Motor run and jog Local/Remote toggle
LED Indicators	Forward run command Reverse run command Stop command Jog active
Remote Mount	100 feet (30.3m) max from control

## Control Specifications:

Control Method	PWM
Command Input	$\pm 10\text{VDC}$
Command Signal Resolution	9 bits + Sign
Feedback Resolution	12 bit
Velocity Loop Bandwidth	Adjustable to 30 Hz
Current Loop Bandwidth	Adjustable to 1500 Hz
Maximum Output Frequency	500 Hz
Quiet PWM Frequency Setting	Full rating 1-8 kHz PWM frequency, Adjustable to 16 kHz with linear derating (between 8 - 16kHz) to 30% at 16 kHz
Standard PWM Frequency Setting	Full rating 1-2.5 kHz PWM frequency, Adjustable to 5 kHz with linear derating (between 2.5 - 5kHz) to 10% at 5 kHz
Selectable Operating Modes	Keypad Standard Run 15 SPD 3SPD ANA 2 Wire 3SPD ANA 3 Wire Serial Bipolar Speed Process EPOT 2 Wire EPOT 3 Wire

## Differential Analog Input:

Common Mode Rejection	40 db
Full Scale Range	$\pm 5\text{VDC}$ , $\pm 10\text{VDC}$ , 4-20 mA
Auto-selectable Resolutions	9 bits + sign

---

## Other Analog Input:

Full Scale Range	0 - 10 VDC (0 to -10VDC and 0 to +10VDC are valid inputs)
Resolution	9 bits + sign

## Analog Outputs:

Analog Outputs	2 Assignable
Full Scale Range	0 - 5 VDC
Source Current	1 mA maximum
Resolution	8 bits

## Digital Inputs:

Opto-isolated Logic Inputs	9 Assignable
Rated Voltage	10 - 30 VDC (closed contacts std)
Input Impedance	6.8 k Ohms
Leakage Current	10 $\mu$ A maximum

## Digital Outputs:

Opto-isolated Logic Outputs	4 Assignable
ON Current Sink	60 mA Max
ON Voltage Drop	2 VDC Max
Maximum Voltage	30 VDC

## Diagnostic Indications:

No Faults	No EXB Installed	
Current Sense Fault	Overload - 1 minute	Logic Supply Fault
Ground Fault	Overload - 3 seconds	Invalid Base ID
	Overcurrent FLT	Inverter Base ID
Line Power Loss	DC Bus High	New Base ID
Microprocessor Reset	DC Bus Low	PWR Base FLT
Coprocessor Fault	Lost User Data	Regen R PWR FLT
Over temperature (Motor or Control)	Low INIT Bus V	Line Regen FLT
Over speed	Memory Error	User FLT Text

Note: All specifications are subject to change without notice.



## Ratings Series 23H Stock Products

CATALOG NO.	INPUT VOLT	SIZE	QUIET 8.0 kHz PWM								STANDARD 2.5 kHz PWM							
			CONSTANT TORQUE				VARIABLE TORQUE				CONSTANT TORQUE				VARIABLE TORQUE			
			IC	IP	KW	HP	IC	IP	KW	HP	IC	IP	KW	HP	IC	IP	KW	HP
SD23H2A03-E	230	A	3	6	.56	.75	4	5	.75	1	4	8	.75	1	7	8	1.5	2
SD23H2A04-E, W	230	A	4	8	.75	1	7	8	1.5	2	7	14	1.5	2	10	12	2.2	3
SD23H2A07-E	230	A	7	14	1.5	2	10	12	2.2	3	10	20	2.2	3	16	19	3.7	5
SD23H2A10-E, W	230	A	10	20	2.2	3	16	19	3.7	5	16	32	3.7	5	22	25	5.5	7.5
SD23H2A16-E	230	B	16	32	3.7	5	22	25	5.5	7.5	22	44	5.5	7.5	28	32	7.4	10
SD23H2A22-E	230	B	22	44	5.5	7.5	28	32	7.4	10	28	56	7.4	10	42	48	11.1	15
SD23H2A28-E	230	B	28	56	7.4	10	42	48	11.1	15	42	84	11.1	15	42	48	11.1	15
SD23H2A42-EO	230	C2	42	92	11.1	15	54	62	14.9	20	55	110	14.9	20	68	78	18.6	25
SD23H2A54-ER	230	C2	54	92	14.9	20	68	78	18.6	25	68	116	18.6	25	80	92	22.3	30
SD23H4A04-E	460	A	4	8	1.5	2	5	6	2.2	3	5	10	2.2	3	8	10	3.7	5
SD23H4A05-E	460	A	5	10	2.2	3	8	10	3.7	5	8	16	3.7	5	11	13	5.5	7.5
SD23H4A08-E	460	A	8	16	3.7	5	11	13	5.5	7.5	11	22	5.5	7.5	14	17	7.4	10
SD23H4A11-E	460	B	11	22	5.5	7.5	14	16	7.4	10	14	28	7.4	10	21	24	11.1	15
SD23H4A15-E	460	B	15	30	7.4	10	21	24	11.1	15	21	42	11.1	15				
SD23H4A21-EO	460	C2	21	46	11.1	15	27	31	14.9	20	27	50	14.9	20	34	39	18.6	25
SD23H4A27-ER	460	C2	27	46	14.9	20	34	39	18.6	25	34	58	18.6	25	40	46	22.3	30

Note: -E, -EO= NEMA 1 Enclosure  
 -W= NEMA 4X Enclosure  
 -MO= Protected Chassis (not NEMA1)

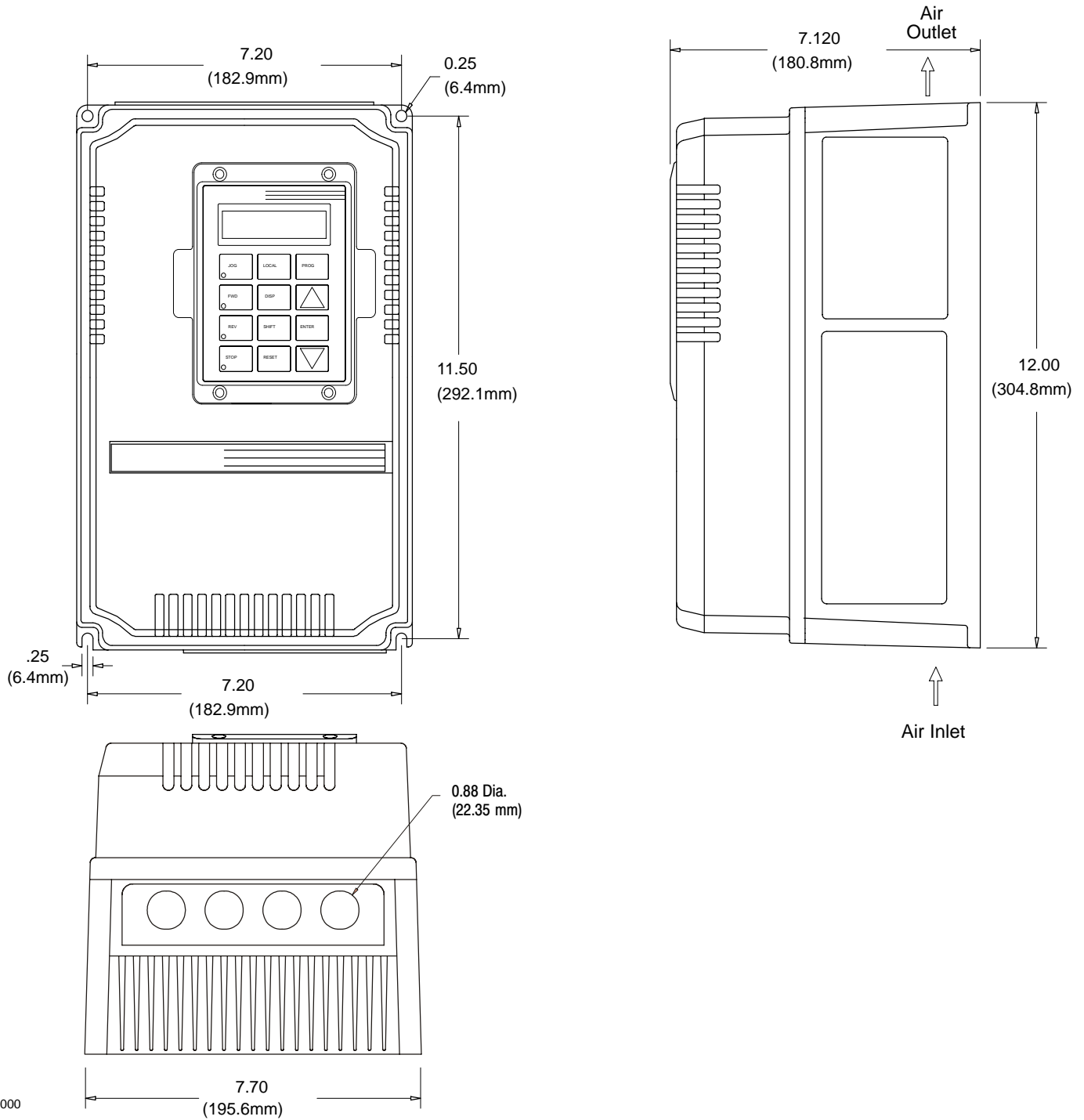
## Terminal Tightening Torque Specifications

Table 7-4 Tightening Torque Specifications

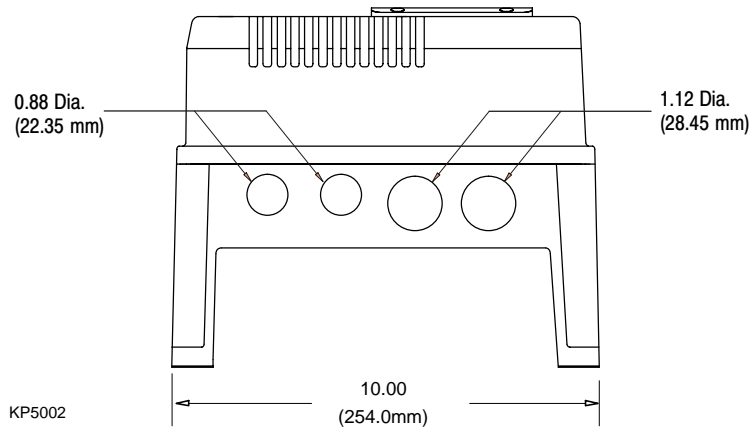
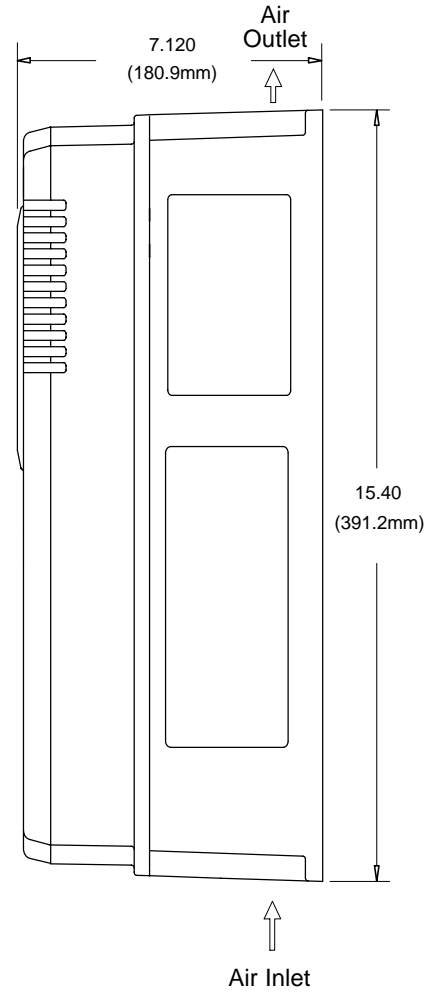
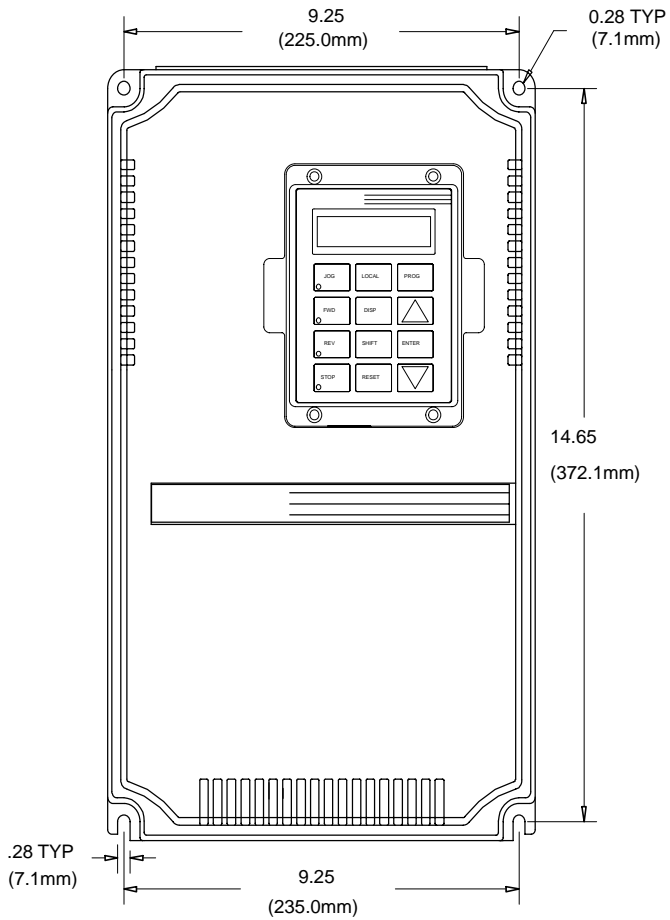
230VAC Catalog Numbers	Size	Tightening Torque									
		Power TB1		Ground		Control J1		B+/R1; B+; B-; or R2		D1/D2	
		Lb-in	Nm	Lb-in	Nm	Lb-in	Nm	Lb-in	Nm	Lb-in	Nm
SD23H2A03-E	A	8	0.9	15	1.7	4.5	0.5	8	0.9		
SD23H2A04-E	A	8	0.9	15	1.7	4.5	0.5	8	0.9		
SD23H2A04-W	A	8	0.9	15	1.7	4.5	0.5	8	0.9		
SD23H2A07-E	A	8	0.9	15	1.7	4.5	0.5	8	0.9		
SD23H2A10-E	A	8	0.9	15	1.7	4.5	0.5	8	0.9		
SD23H2A10-W	A	8	0.9	15	1.7	4.5	0.5	8	0.9		
SD23H2A15-E	B2	20	2.5	15	1.7	4.5	0.5	20	2.5		
SD23H2A16-E	B	20	2.5	15	1.7	4.5	0.5	20	2.5		
SD23H2A16-E	B2	20	2.5	15	1.7	4.5	0.5	20	2.5		
SD23H2A22-E	B	20	2.5	15	1.7	4.5	0.5	20	2.5		
SD23H2A22-E	B2	20	2.5	15	1.7	4.5	0.5	20	2.5		
SD23H2A28-E	B	20	2.5	15	1.7	4.5	0.5	20	2.5		
SD23H2A28-E	B2	20	2.5	15	1.7	4.5	0.5	20	2.5		
SD23H2A30-ER	C	35	4.0	35	4.0	4.5	0.5	50	5.6	32	3.6
SD23H2A42-E	B2	20	2.5	15	1.7	4.5	0.5	20	2.5		
SD23H2A42-EO	C2	50	5.6	50	5.6	4.5	0.5	50	5.6	32	3.6
SD23H2A45-ER	C	35	4.0	35	4.0	4.5	0.5	50	5.6	32	3.6
SD23H2A54-ER	C2	50	5.6	50	5.6	4.5	0.5	50	5.6	32	3.6
SD23H2A55-ER	C	35	4.0	35	4.0	4.5	0.5	50	5.6	32	3.6
460VAC Catalog Numbers	Size	Tightening Torque									
		Power TB1		Ground		Control J1		B+/R1; B+; B-; or R2		D1/D2	
		Lb-in	Nm	Lb-in	Nm	Lb-in	Nm	Lb-in	Nm	Lb-in	Nm
SD23H4A04-E	A	8	0.9	15	1.7	4.5	0.5	8	0.9		
SD23H4A05-E	A	8	0.9	15	1.7	4.5	0.5	8	0.9		
SD23H4A08-E	A	8	0.9	15	1.7	4.5	0.5	8	0.9		
SD23H4A11-E	B	20	2.5	15	1.7	4.5	0.5	20	2.5		
SD23H4A11-E	B2	20	2.5	15	1.7	4.5	0.5	20	2.5		
SD23H4A14-E	B	20	2.5	15	1.7	4.5	0.5	20	2.5		
SD23H4A14-E	B2	20	2.5	15	1.7	4.5	0.5	20	2.5		
SD23H4A15-E	B	20	2.5	15	1.7	4.5	0.5	20	2.5		
SD23H4A15-E	B2	20	2.5	15	1.7	4.5	0.5	20	2.5		
SD23H4A15-ER	C	35	4.0	35	4.0	4.5	0.5	50	5.6	32	3.6
SD23H4A21-E	B2	20	2.5	15	1.7	4.5	0.5	20	2.5		
SD23H4A21-EO	C2	50	5.6	50	5.6	4.5	0.5	50	5.6	32	3.6
SD23H4A22-ER	C	35	4.0	35	4.0	4.5	0.5	50	5.6	32	3.6
SD23H4A27-ER	C2	50	5.6	50	5.6	4.5	0.5	50	5.6	32	3.6
SD23H4A30-ER	C	35	4.0	35	4.0	4.5	0.5	50	5.6	32	3.6

## Dimensions

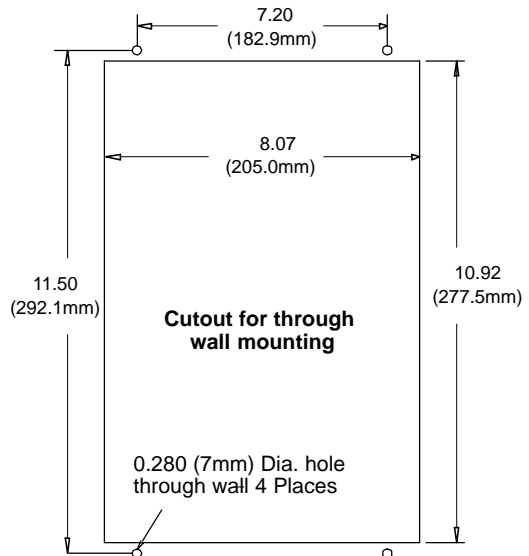
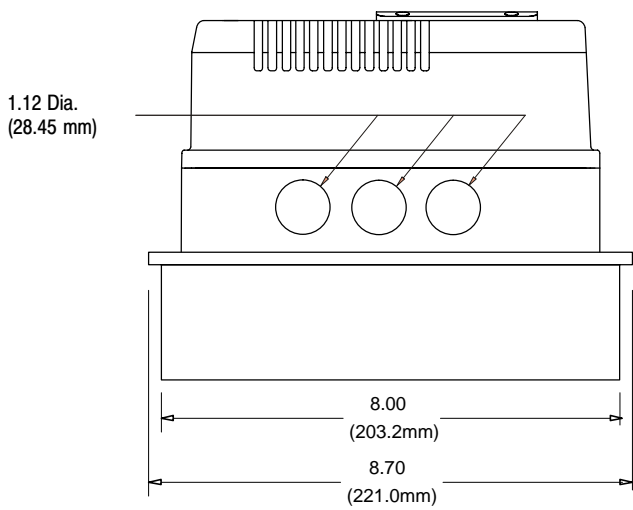
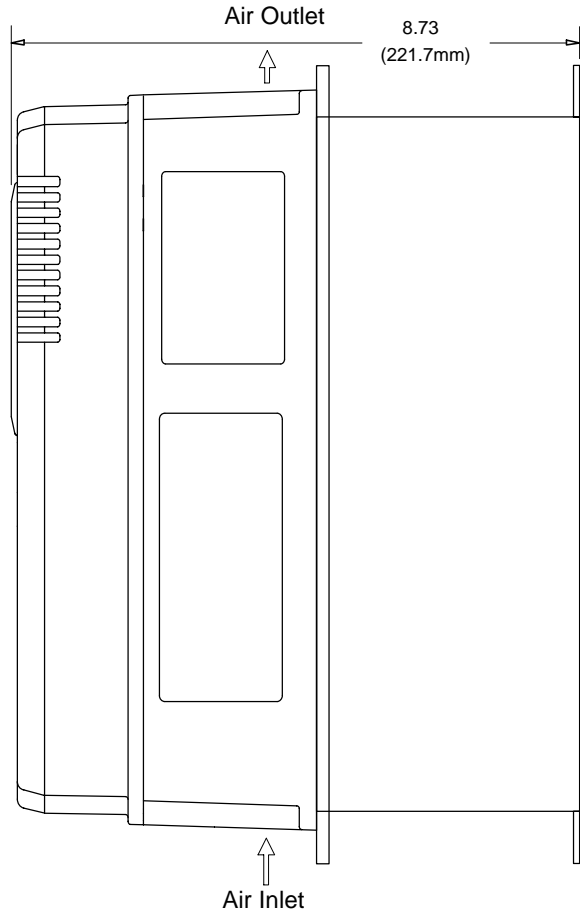
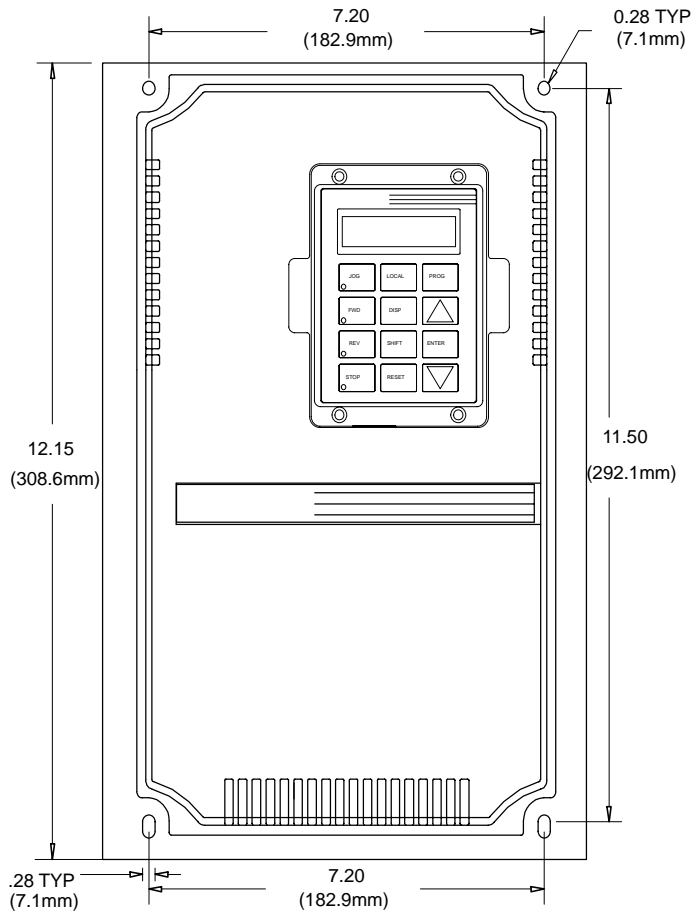
### Size A Control



**Dimensions Continued**  
**Size B Control**

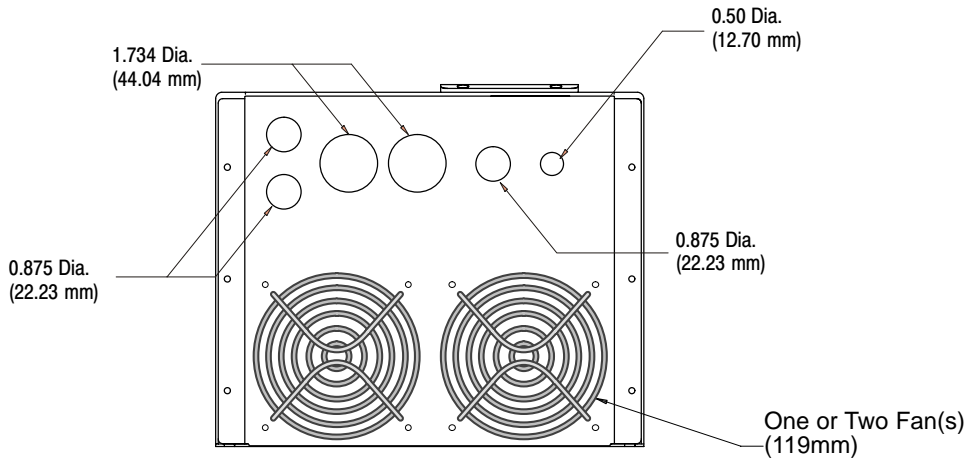
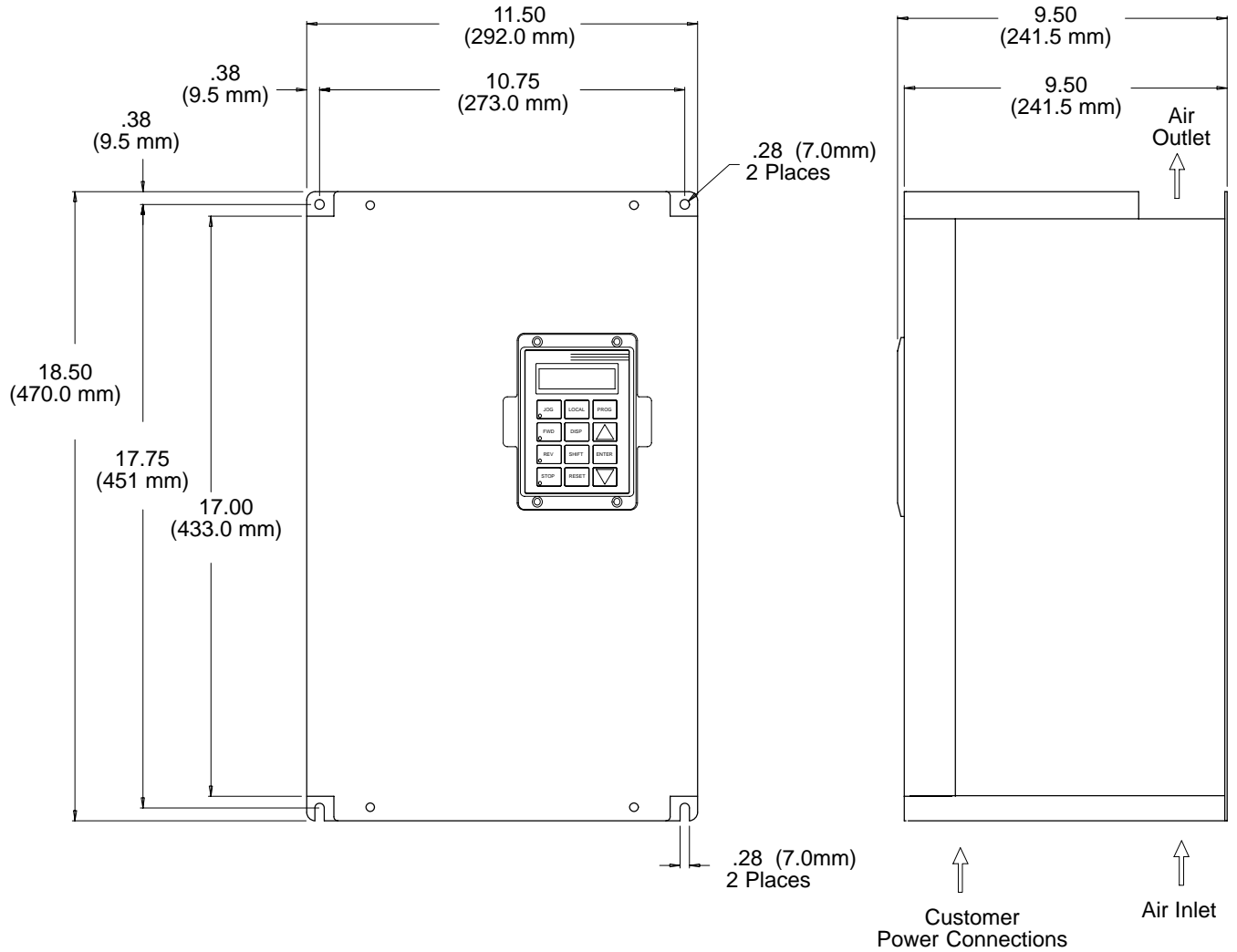


**Dimensions Continued**  
**Size B2 Control**



OM0001A15

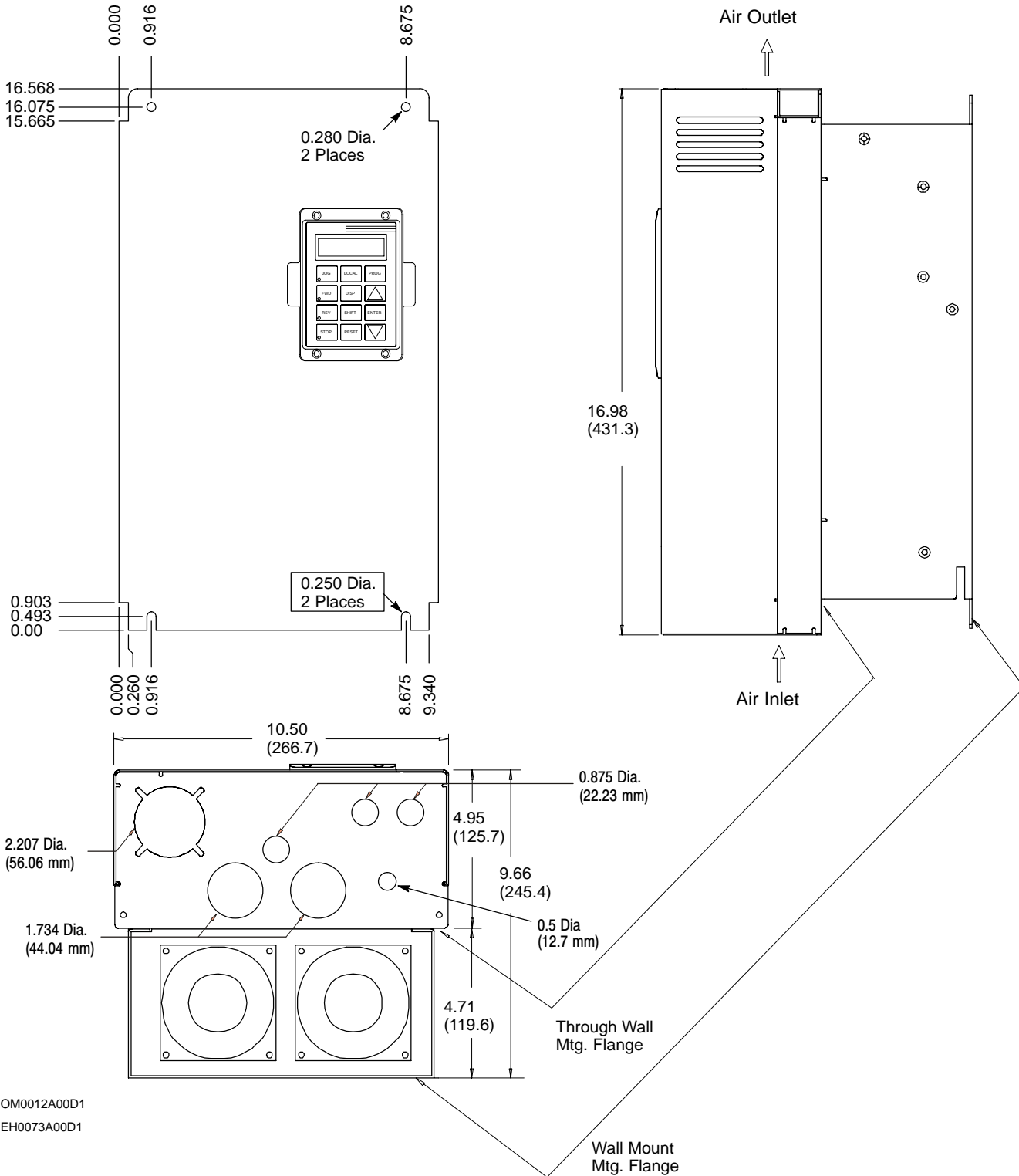
**Dimensions Continued**  
**Size C Control**



V8525

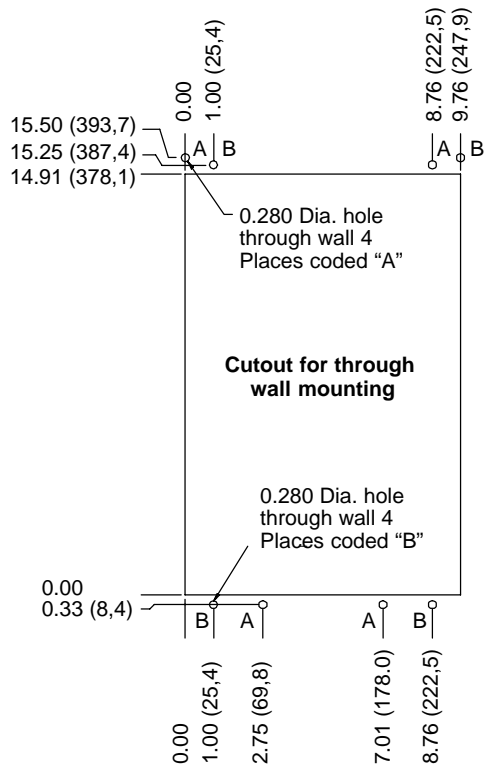
**Dimensions** Continued

**Size C2 Control**



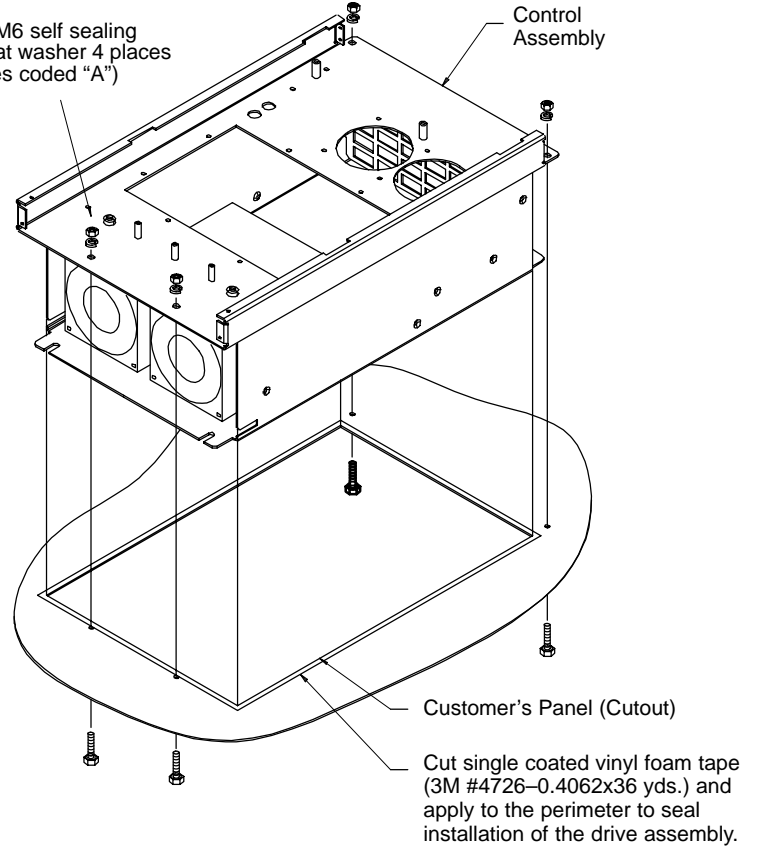
**Dimensions** Continued

**Size C2 Control – Through-Wall Mounting**



Note: Throughwall mounting provides NEMA 4 protection.  
For clarity, cover and inside components not shown.

1/4-20 or M6 self sealing bolt and flat washer 4 places each (holes coded "A")

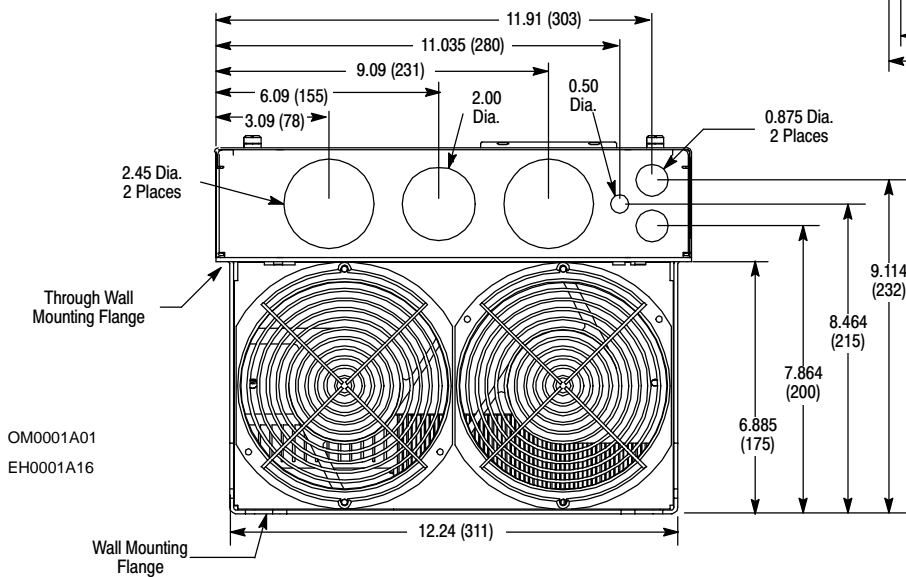
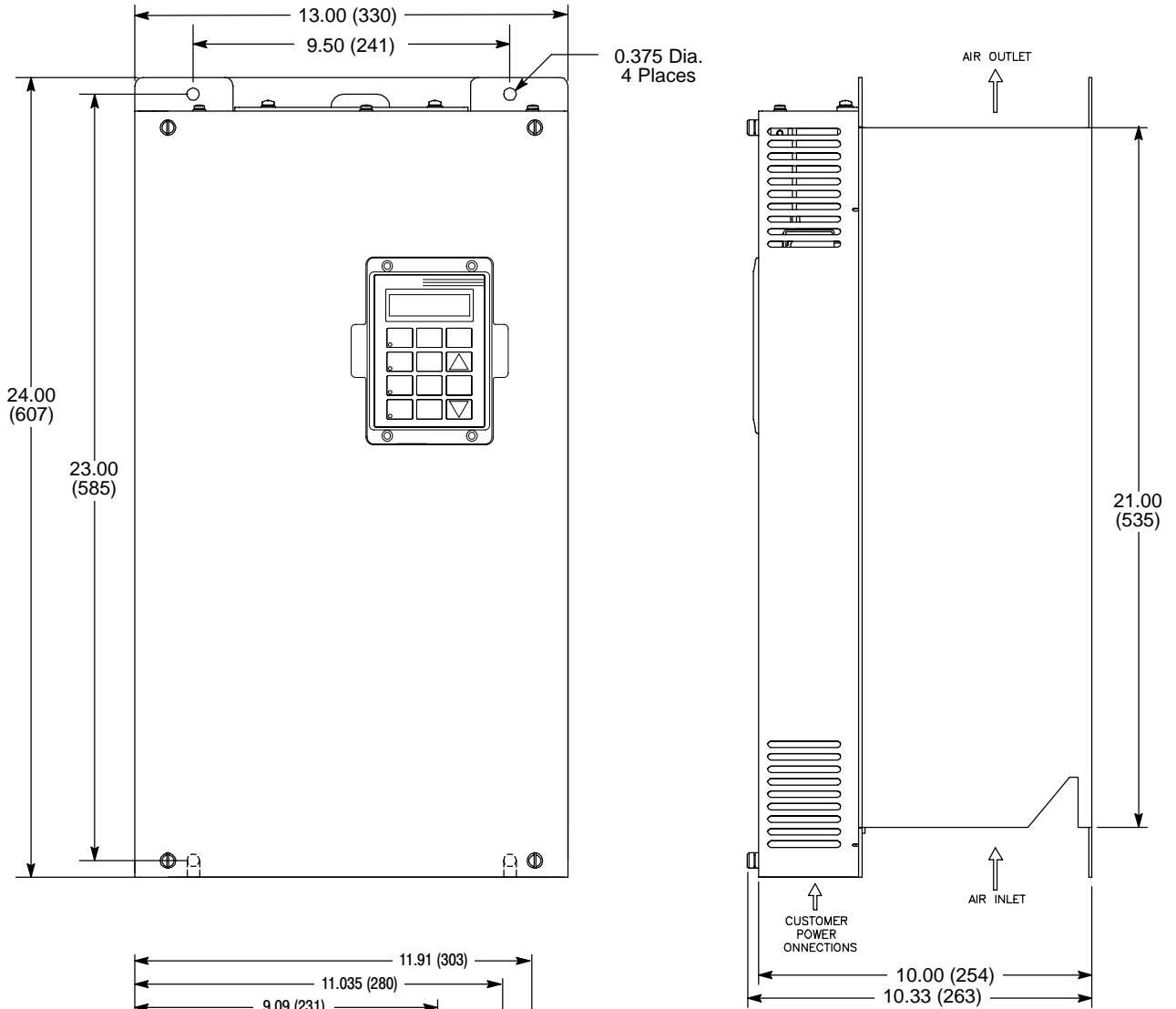






**Dimensions Continued**

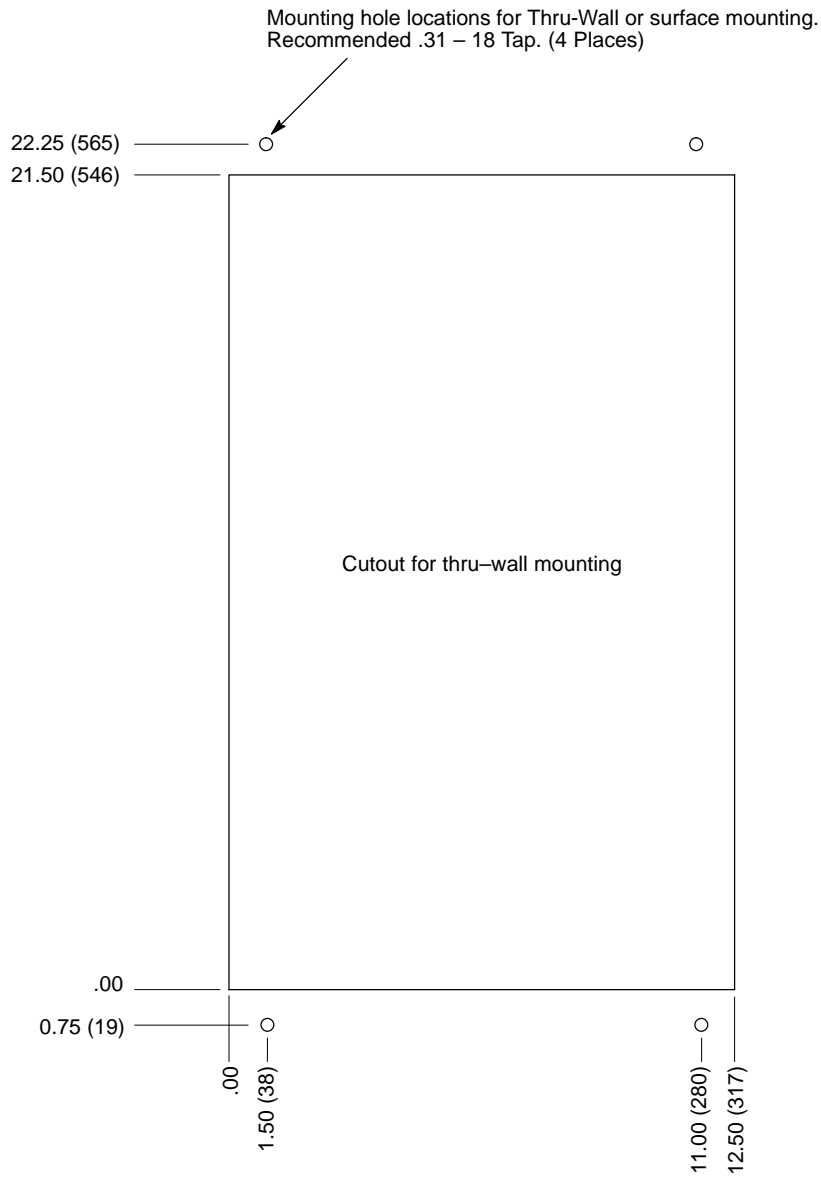
**Size D2 Control**



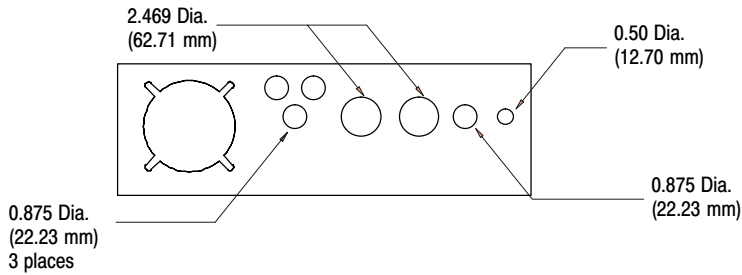
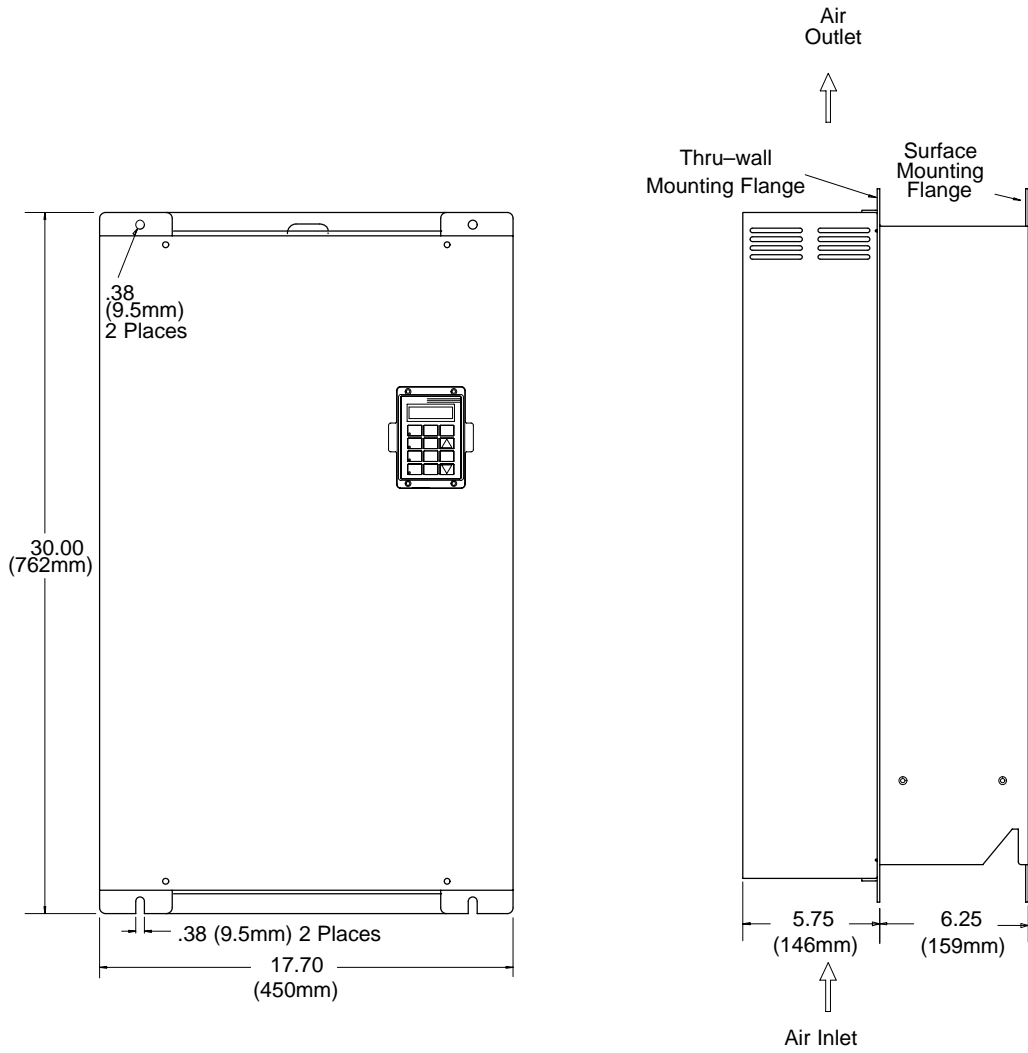
---

**Dimensions** Continued

**Size D2 Control – Thru-Wall Mounting**



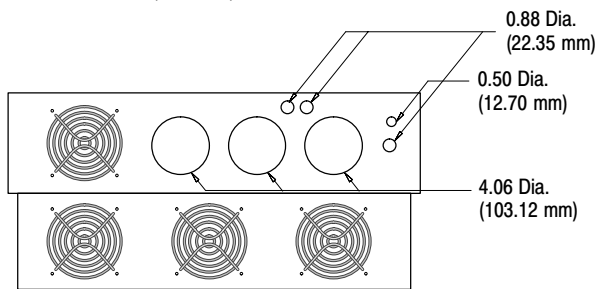
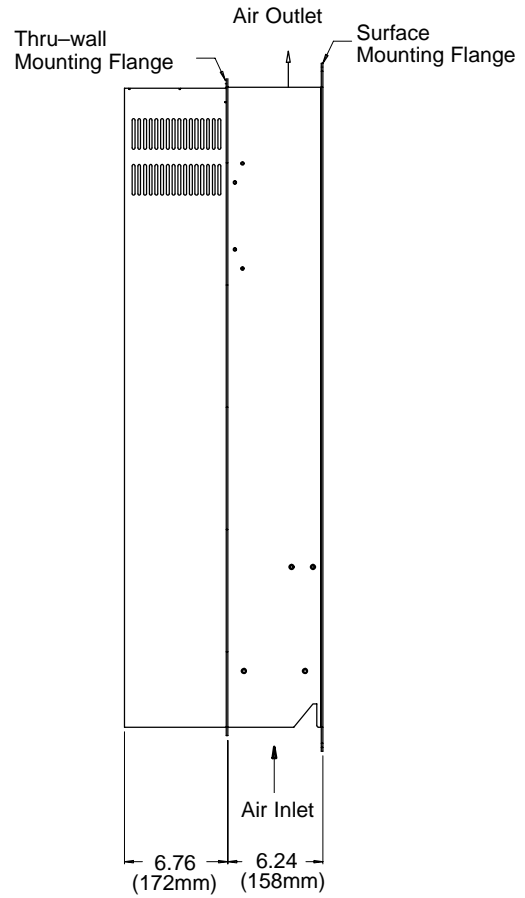
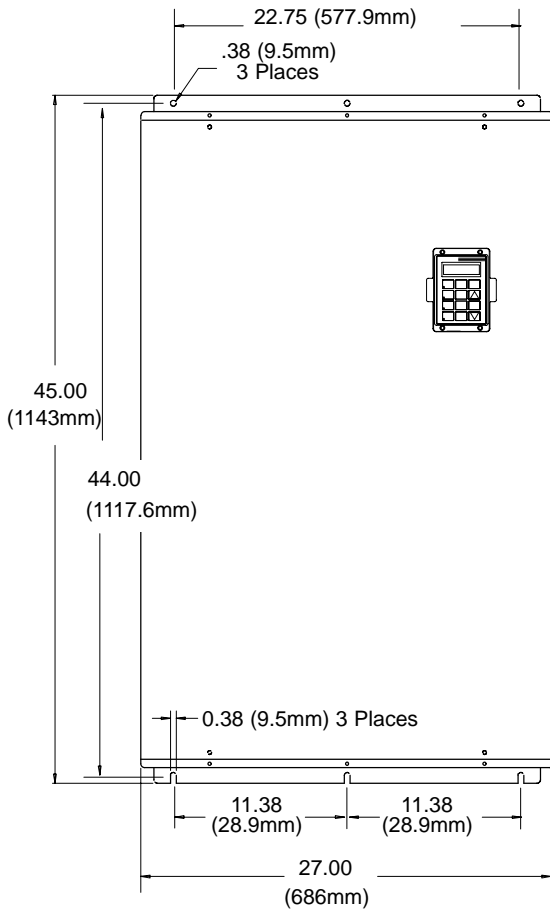
**Dimensions Continued**  
**Size E Control**



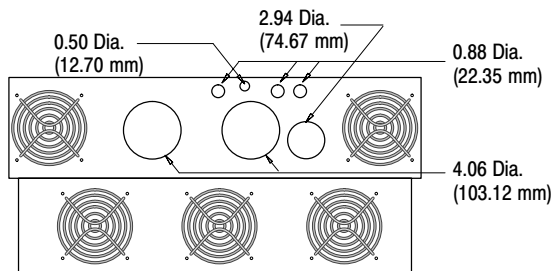
V8316  
 EH0001A43

**Dimensions Continued**

**Size F Control**



**Standard Regen & Non-Regen**

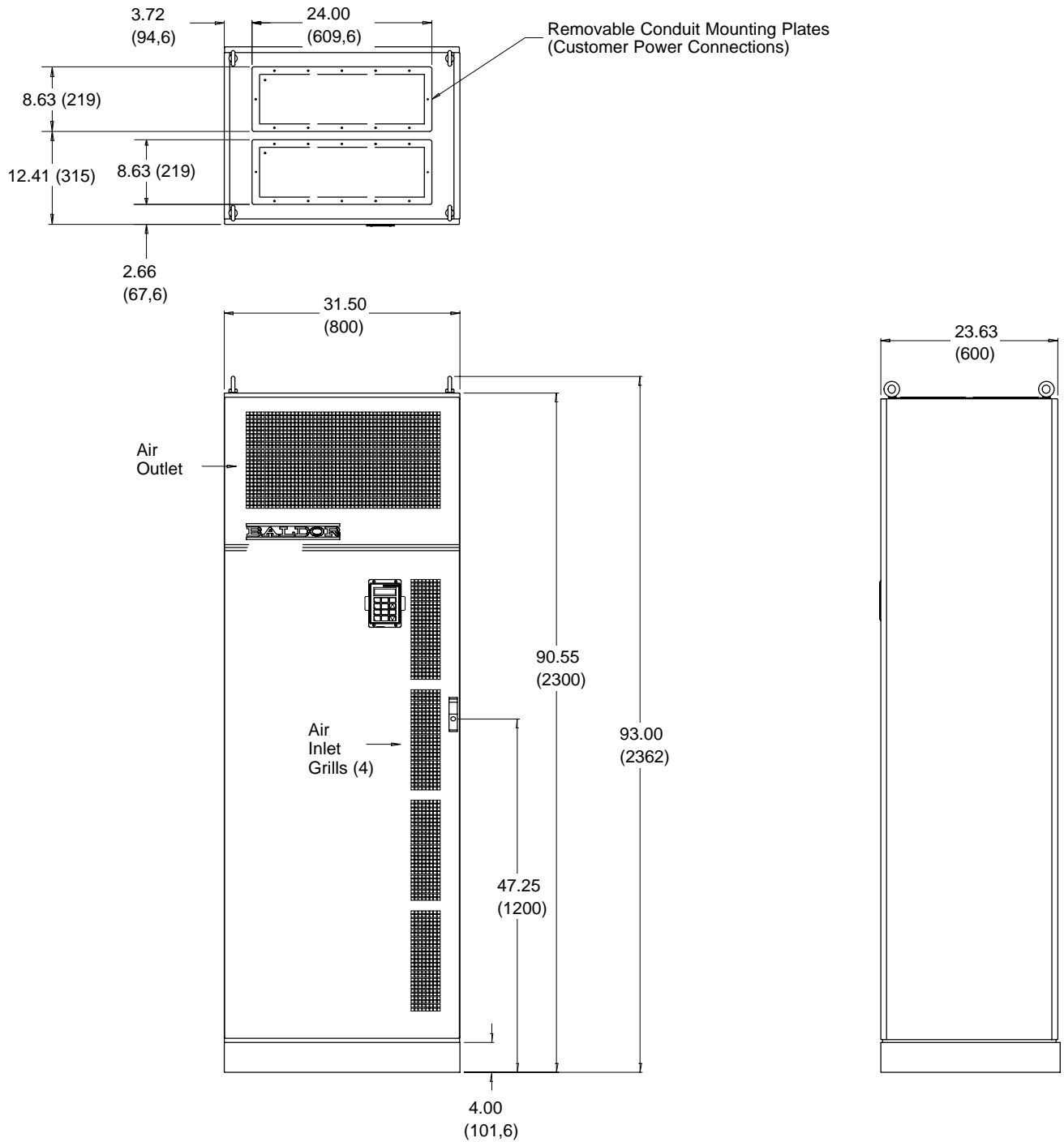


**Non-Regen with DC Link Inductor**

OM0031A00D1

**Dimensions Continued**

**Size G Control**



V1373



# Appendix A

**Dynamic Braking (DB) Hardware** Whenever a motor is abruptly stopped or forced to slow down quicker than if allowed to coast to a stop, the motor becomes a generator. This energy appears on the DC Bus of the control and must be dissipated using dynamic braking hardware. Dynamic braking (DB) hardware can be a resistor or transistor load. Table A-1 provides a matrix of DB turn ON and turn OFF voltages.

**Table A-1**

Parameter Description	Control Input Voltage	
	Nominal Voltage	230VAC
Overvoltage Fault (Voltage exceeded)	400VDC	800VDC
DB ON Voltage	381VDC	762VDC
DB Upper Tolerance Peak *	388VDC	776VDC
DB OFF Voltage	375VDC	750VDC

\* DB Upper Tolerance Peak =  $1.02 \times \sqrt{2} \times V_{L-L}$

Braking torque and time should not exceed the available drive braking torque and time rating. The drive braking torque is limited to the available peak current and peak current time rating of the control. If the peak current or peak current time limit is exceeded during braking, the control may trip on an over voltage or a regen power fault. Selecting an oversized control or a line regenerative control should be considered in these cases.

### Selection Procedure

1. Calculate the watts to be dissipated using the following formulas for the appropriate load type.
2. Identify the control model number and determine which braking hardware is required based on the model number suffix: E, EO, ER, MO or MR.
3. Select appropriate braking hardware from Baldor 501 Catalog or Tables A-2, A-3 and A-4.

### Hoisting Load Calculations

1. Calculate braking duty cycle:  

$$\text{Duty Cycle} = \frac{\text{Lowering Time}}{\text{Total Cycle Time}}$$
2. Calculate braking watts to be dissipated in dynamic braking resistors:

$$\text{Watts} = \frac{\text{duty cycle} \times \text{lbs} \times \text{FPM} \times \text{efficiency}}{44}$$

where: lbs = weight of load  
 FPM = Feet Per Minute  
 efficiency = mechanical efficiency  
 i.e., 95% = 0.95

Continued on next page.



---

Dynamic Braking (DB) Hardware Continued

**General Machinery Load Calculations:**

1. Calculate braking duty cycle:

$$\text{Duty Cycle} = \frac{\text{Braking Time}}{\text{Total Cycle Time}}$$

2. Calculate deceleration torque:

$$T_{\text{Decel}} = \frac{\text{RPM change} \times Wk^2}{308 \times \text{time}} - \text{Friction}_{(\text{Lb.Ft.})}$$

where:  $T_{\text{Decel}}$  = Deceleration torque in Lb.-ft.  
 $Wk^2$  = Inertia in Lb.ft.<sup>2</sup>  
time = In seconds

3. Calculate watts to be dissipated in dynamic braking resistor:

$$\text{Watts} = T_{\text{Decel}} \times (S_{\text{max}} - S_{\text{min}}) \times \text{Duty Cycle} \times (0.0712)$$

where:  $S_{\text{max}}$  = Speed at braking start  
 $S_{\text{min}}$  = Speed after braking

4. Multiply watts calculated in step 3 by 1.25 to allow for unanticipated loads (safety factor).

---

**Dynamic Braking (DB) Hardware** Continued

**Catalog Numbers with an “E” Suffix**

These controls are equipped with a factory installed dynamic brake transistor and brake resistor(s). Size A controls have 400 watts and size B controls have 800 watts of dissipation. These can provide 100% braking torque for 6 seconds of a 20% braking duty cycle. Should additional braking capacity be required an optional externally mounted RGA brake resistor can be used in lieu of the internal resistors. See RGA assemblies.

**Catalog Numbers with an “ER” or “MR” Suffix**

These controls include a factory installed dynamic braking transistor. If dynamic braking is required, use an optional external RGA brake resistor. See RGA assemblies.

**Catalog Numbers with an “EO” or “MO” Suffix**

No dynamic braking hardware is installed in these controls. If dynamic braking is required, an optional RBA assembly or a combination of RTA and RGA assemblies should be added. The RBA assembly provides up to 4,000 watts dynamic braking capacity. Should more capacity be required, a combination of an RTA (DB transistor) and RGA (DB resistor) should be used. Refer to RBA, RTA and RGA Assemblies description.

**Dynamic Braking (DB) Hardware** Continued

**RGA Assemblies**

RGA Assemblies include braking resistors completely assembled and mounted in a NEMA 1 enclosure. A listing of available RGA assemblies is provided in Table A-2. The minimum resistance “Minimum Ohms” shown in the table is the minimum resistor value that can be connected to the control without causing damage to the internal dynamic brake transistor for E, ER and MR controls.

RGA assemblies can also be used with EO and MO controls in combination with an RTA assembly when more than 4000 watts of brake capacity is needed. In this case, the minimum resistance of the RGA assembly must be equal to or greater than the minimum resistance specified for the RTA assembly. Refer to Section 3 “Optional Dynamic Brake Hardware” for wiring diagram.

**Table A-2 Dynamic Braking Resistor Assemblies (RGA)**

Input Volts	HP	Minimum Ohms	Continuous Rated Watts						
			600	1200	2400	4800	6400	9600	14200
230	1 - 2	30	RGA630	RGA1230	RGA2430				
	3 - 5	20	RGA620	RGA1220	RGA2420	RGA4820			
	7.5 - 10	10		RGA1210	RGA2410	RGA4810			
	15 - 20	6		RGA1206	RGA2406	RGA4806			
	25 - 40	4		RGA1204	RGA2404	RGA4804			
	50	2			RGA2402	RGA4802	RGA6402	RGA9602	RGA14202
460	1 - 3	120	RGA6120	RGA12120	RGA24120				
	5 - 7.5	60	RGA660	RGA1260	RGA2460	RGA4860			
	10	30	RGA630	RGA1230	RGA2430	RGA4830			
	15 - 25	20	RGA620	RGA1220	RGA2420	RGA4820			
	30 - 60	10		RGA1210	RGA2410	RGA4810			
	75 - 250	4		RGA1204	RGA2404	RGA4804	RGA6404	RGA9604	RGA14204
	300 - 450	2			RGA2402	RGA4802	RGA6402	RGA9602	RGA14202

**Dynamic Braking (DB) Hardware** Continued

**RBA Assemblies**

An RBA Assembly includes a dynamic brake transistor and resistors completely assembled and mounted in a NEMA 1 enclosure. They are designed for EO and MO controls. Select the RBA based on the voltage rating of the control and the dynamic brake watt capacity required. Use Table A-3 to select the RBA assembly. If more than 4,000 watts of brake capacity is required, use a combination of RTA (DB transistor) and RGA (DB resistor) assemblies. Refer to Section 3 "Optional Dynamic Brake Hardware" for wiring diagram.

**Table A-3 Dynamic Braking Assemblies (RBA)**

		MAXIMUM BRAKING TORQUE IN % OF MOTOR RATING												Cont. Watts	Catalog No.
		HP	20	25	30	40	50	60	75	100	150V	150	200		
INPUT VOLTAGE	200 to 240	90%	75%	60%	45%	36%								600	RBA2-610
		150%	125%	100%	75%	62%								1800	RBA2-1806
		150%	150%	150%	115%	92%								4000	RBA2-4004
	380 to 480	150%	150%	120%	90%	72%	60%	48%	36%	28%				600	RBA4-620
		150%	150%	120%	90%	72%	60%	48%	36%	28%				1800	RBA4-1820
		150%	150%	150%	150%	150%	120%	96%	72%	56%	48%	36%	29%	4000	RBA4-4010

**Dynamic Braking (DB) Hardware** Continued

**RTA Assemblies**

RTA assemblies include a dynamic brake transistor and gate driver circuit board completely assembled and mounted in a NEMA 1 enclosure. Brake resistors are not included in the RTA assembly. Each RTA assembly is designed to be used with an RGA dynamic brake resistor assembly. The minimum resistance of the RGA assembly must be equal to or greater than the minimum resistance specified for the RTA assembly. Select the RTA based on the voltage rating of the control and HP which provides the dynamic brake watt capacity required. Use Table A-4 to select the RTA assembly. Refer to Section 3 "Optional Dynamic Brake Hardware" for wiring diagram.

**Table A-4 Dynamic Braking Transistor Assemblies (RTA)**

HP	MAXIMUM BRAKING TORQUE IN % OF MOTOR RATING						
	208 - 230 VAC			380 - 480 VAC			
20	150%	150%	150%	150%	150%	150%	150%
25	125%	150%	150%	150%	150%	150%	150%
30	100%	150%	150%	120%	150%	150%	150%
40	75%	115%	150%	90%	150%	150%	150%
50	62%	92%	150%	72%	150%	150%	150%
60				60%	150%	150%	150%
75				48%	96%	150%	150%
100				36%	72%	150%	150%
150V				28%	56%	150%	150%
150					48%	126%	150%
200					36%	95%	150%
250					29%	76%	150%
300						62%	125%
350						54%	108%
400						47%	94%
450						41%	84%
<b>CAT. NO.</b>	<b>RTA2-6</b>	<b>RTA2-4</b>	<b>RTA2-2</b>	<b>RTA4-20</b>	<b>RTA4-10</b>	<b>RTA4-4</b>	<b>RTA4-2</b>
Minimum Ohms	6	4	2	20	10	4	2

# Appendix B

## Parameter Values (Version 3.12)

### Table B-1 Parameter Block Values Level 1

Level 1 Blocks					
Block Title	Parameter	P#	Adjustable Range	Factory Setting	User Setting
PRESET SPEEDS	PRESET SPEED #1	1001	0-MAX Speed	0 RPM	
	PRESET SPEED #2	1002	0-MAX Speed	0 RPM	
	PRESET SPEED #3	1003	0-MAX Speed	0 RPM	
	PRESET SPEED #4	1004	0-MAX Speed	0 RPM	
	PRESET SPEED #5	1005	0-MAX Speed	0 RPM	
	PRESET SPEED #6	1006	0-MAX Speed	0 RPM	
	PRESET SPEED #7	1007	0-MAX Speed	0 RPM	
	PRESET SPEED #8	1008	0-MAX Speed	0 RPM	
	PRESET SPEED #9	1009	0-MAX Speed	0 RPM	
	PRESET SPEED #10	1010	0-MAX Speed	0 RPM	
	PRESET SPEED #11	1011	0-MAX Speed	0 RPM	
	PRESET SPEED #12	1012	0-MAX Speed	0 RPM	
	PRESET SPEED #13	1013	0-MAX Speed	0 RPM	
	PRESET SPEED #14	1014	0-MAX Speed	0 RPM	
	PRESET SPEED #15	1015	0-MAX Speed	0 RPM	
ACCEL/DECEL RATE	ACCEL TIME #1	1101	0 to 3600 Seconds	3.0 SEC	
	DECEL TIME #1	1102	0 to 3600 Seconds	3.0 SEC	
	S-CURVE #1	1103	0-100%	0 %	
	ACCEL TIME #2	1104	0 to 3600 Seconds	3.0 SEC	
	DECEL TIME #2	1105	0 to 3600 Seconds	3.0 SEC	
	S-CURVE #2	1106	0-100%	0 %	
JOG SETTINGS	JOG SPEED	1201	0-MAX Speed	200 RPM	
	JOG ACCEL TIME	1202	0 to 3600 Seconds	3.0 SEC	
	JOG DECEL TIME	1203	0 to 3600 Seconds	3.0 SEC	
	JOG S-CURVE TIME	1204	0-100%	0 %	
KEYPAD SETUP	KEYPAD STOP KEY	1301	0-REMOTE OFF (Stop key inactive during remote operation). 1-REMOTE ON (Stop key active during remote operation).	REMOTE ON	
	KEYPAD STOP MODE	1302	0-COAST, 1-REGEN	REGEN	
	KEYPAD RUN FWD	1303	0-OFF, 1-ON	ON	
	KEYPAD RUN REV	1304	0-OFF, 1-ON	ON	
	KEYPAD JOG FWD	1305	0-OFF, 1-ON	ON	
	KEYPAD JOG REV	1306	0-OFF, 1-ON	ON	
	LOC HOT START	1307	0-OFF, 1-ON	OFF	

**Table B-1 Parameter Block Values Level 1** Continued

Level 1 Blocks - Continued					
Block Title	Parameter	P#	Adjustable Range	Factory	User Setting
INPUT	OPERATING MODE	1401	1-KEYPAD 2-STANDARD RUN 3-15SPD 4-3SPD ANA 2 WIRE 5-3SPD ANA 3 WIRE 6-SERIAL 7-BIPOLAR 8-PROCESS MODE 9-EPOT - 2 WIRE 10-EPOT - 3 WIRE	KEYPAD	
	COMMAND SELECT	1402	0-POTENTIOMETER 1-+/-10 VOLTS 2-+/-5 VOLTS 3-4 TO 20 mA 4-10V W/ TORQ FF 5-EXB PULSE FOL 6-5V EXB 7-10 VOLT EXB 8-4-20mA EXB 9-3-15 PSI EXB 10-TACHOMETER EXB 11-SERIAL 12-NONE	+/-10 VOLTS	
	ANA CMD INVERSE	1403	0-OFF, 1-ON	OFF	
	ANA CMD OFFSET	1404	-20.0 to +20.0% (where $\pm 0.5V = \pm 20\%$ )	0.0 %	
	ANA 2 DEADBAND	1405	0-10.00 V	0.00 V	
	ANA 1 CUR LIMIT	1406	0-OFF, 1-ON	OFF	
OUTPUT	OPTO OUTPUT #1	1501	0-READY 1-ZERO SPEED 2-AT SPEED 3-OVERLOAD	READY	
	OPTO OUTPUT #2	1502	4-KEYPAD CONTROL 5-AT SET SPEED 6-FAULT 7-FOLLOWING ERR 8-MOTR DIRECTION	ZERO SPEED	
	OPTO OUTPUT #3	1503	9-DRIVE ON 10-CMD DIRECTION 11-AT POSITION 12-OVER TEMP WARN	AT SPEED	
	OPTO OUTPUT #4	1504	13-PROCESS ERROR 14-DRIVE RUN 15-SERIAL	FAULT	
	ZERO SPD SET PT	1505	1-2500	200 RPM	
	AT SPEED BAND	1506	1-1000 RPM	100 RPM	
	SET SPEED	1507	0-2500	2500 RPM	

**Table B-1 Parameter Block Values Level 1** Continued

Level 1 Blocks - Continued					
Block Title	Parameter	P#	Adjustable Range	Factory	User Setting
OUTPUT (Continued)	ANALOG OUT #1	1508	0-ABS SPEED 1-ABS TORQUE 2-SPEED COMMAND 3-PWM VOLTAGE 4-FLUX CURRENT 5-CMD FLUX CUR 6-LOAD CURRENT 7-CMD LOAD CUR 8-MOTOR CURRENT 9-LOAD COMPONENT 10-QUAD VOLTAGE 11-DIRECT VOLTAGE	ABS SPEED	
	ANALOG OUT #2	1509	12-AC VOLTAGE 13-BUS VOLTAGE 14-TORQUE 15-POWER 16-VELOCITY 17-OVERLOAD 18-PH2 CURRENT 19-PH3 CURRENT 20-PROCESS FDBK 21-SETPOINT CMD 22-POSITION 23-SERIAL	MOTOR CURRENT	
	ANALOG #1 SCALE	1510	10 - 100%	100%	
	ANALOG #2 SCALE	1511	10 - 100%	100%	
	POSITION BAND	1512	1-32767 CNTS	6 CNTS	
BRUSHLESS CONTROL	RESOLVER ALIGN	1601	0.0-360.0 DEG	CALC	
	SPEED FILTER	1602	0-7	4	
	FEEDBACK ALIGN	1603	0-REVERSE, 1-FORWARD	FORWARD	
	CURRENT PROP GAIN	1604	0-1000	200	
	CURRENT INT GAIN	1605	0-400	150 HZ	
	SPEED PROP GAIN	1606	0-1000	10	
	SPEED INT GAIN	1607	0.00-9.99	1.00 HZ	
	SPEED DIFF GAIN	1608	0-100	0	
	POSITION GAIN	1609	0-9999	31	
LEVEL 2 BLOCK	ENTERS LEVEL 2 MENU - See Table B-2.				
PRESS ENTER FOR PROGRAMMING EXIT	Exit programming mode and return to display mode.				



**Table B-2 Parameter Block Values Level 2**

Level 2 Blocks					
Block Title	Parameter	P#	Adjustable Range	Factory	User Setting
OUTPUT LIMITS	OPERATING ZONE	2001	1-STD CONST TQ 2-STD VAR TQ 3-QUIET CONST TQ 4-QUIET VAR TQ	QUIET CONST TQ	
	MIN OUTPUT SPEED	2002	0-2500	0 RPM	
	MAX OUTPUT SPEED	2003	0-22500 RPM (4 Pole Motor)	2500	
	PK CURRENT LIMIT	2004	0-14.0	CALC	
	PWM FREQUENCY	2005	1.0-5.0 KHZ (Standard) 1.0-16.0 KHZ (Quiet)	8.0 KHZ	
	CUR RATE LIMIT	2006	0-10.000 SEC	0.004 SEC	
CUSTOM UNITS	MAX DECIMAL PLACES	2101	0-5	5	
	VALUE AT SPEED	2102	1-65535/1-65535	1/ 01000	
	VALUE DEC PLACES	2103	0-5 (Serial Only)	0	
	VALUE SPEED REF	2104	1 to 65535 (Serial Only)	00000/ 01000	
	UNITS OF MEASURE	2105	See Table 4-3.	-	
	UNITS OF MEASURE 2	2106	See Table 4-3. (Serial Only)	-	
PROTECTION	OVERLOAD	2201	0-FAULT, 1-FOLDBACK	FOLDBACK	
	EXTERNAL TRIP	2202	0-OFF, 1-ON	OFF	
	LOCAL ENABLE INP	2203	0-OFF, 1-ON	OFF	
	FOLLOWING ERROR	2204	0-OFF, 1-ON	OFF	
MISCELLANEOUS	RESTART AUTO/MAN	2301	0-MANUAL, 1-AUTOMATIC	MANUAL	
	RESTART FAULT/HR	2302	0-10	0	
	RESTART DELAY	2303	0-120 SECONDS	0 SEC	
	FACTORY SETTINGS	2304	0-NO, 1-YES	NO	
	HOMING SPEED	2305	0-MAX Speed	100 RPM	
	HOMING OFFSET	2306	0-65535 CNTS	1024	
SECURITY CONTROL	SECURITY STATE	2401	0-OFF 1-LOCAL SECURITY 2-SERIAL SECURITY 3-TOTAL SECURITY	OFF	
	ACCESS TIMEOUT	2402	0-600 SEC	0 SEC	
	ACCESS CODE	2403	0-9999	9999	
MOTOR DATA	MOTOR RATED AMPS	2501	0-999.9	CALC	
	MOTOR POLES	2502	0-100	4	
	RESOLVER SPEEDS	2503	0 - 10	1	
	CALC PRESETS	2204	0-NO, 1-YES	NO	

**Table B-2 Parameter Block Values Level 2** Continued

Level 2 Blocks - Continued					
Block Title	Parameter	P#	Adjustable Range	Factory	User Setting
BRAKE ADJUST	RESISTOR OHMS	2601	0-250 OHMS	30.0 OHM	
	RESISTOR WATTS	2602	0-360KW	0.40 KW	
PROCESS CONTROL	PROCESS FEEDBACK	2701	0-POTENTIOMETER 1-+/-10VOLTS 2-+/-5 VOLTS 3-4 TO 20mA 4-5V EXB 5-10V EXB 6-4-20mA EXB 7-3-15 PSI EXB 8-TACHOMETER EXB 9-NONE	NONE	
	PROCESS INVERSE	2702	0-OFF, 1-ON	OFF	
	SETPOINT SOURCE	2703	0-POTENTIOMETER 1-+/-10VOLTS 2-+/-5 VOLTS 3-4 TO 20mA 4-5V EXB 5-10V EXB 6-4-20mA EXB 7-3-15 PSI EXB 8-TACHOMETER EXB 9-NONE 10-SETPOINT CMD	SETPOINT CMD	
	SETPOINT COMMAND	2704	-100% to +100%	0.0 %	
	SET PT ADJ LIMIT	2705	0-100%	10.0 %	
	PROCESS ERR TOL	2706	1-100%	10 %	
	PROCESS PROP GAIN	2707	0-2000	0	
	PROCESS INT GAIN	2708	0-9.99 HZ	0.00 HZ	
	PROCESS DIFF GAIN	2709	0-1000	0	
	FOLLOW I:O RATIO	2710	(1-65535) : (1-20)	1:1	
	FOLLOW I:O OUT	2711	1-65535:1-65535	1:1	
MASTER ENCODER	2712	50-65535	1024 PPR		

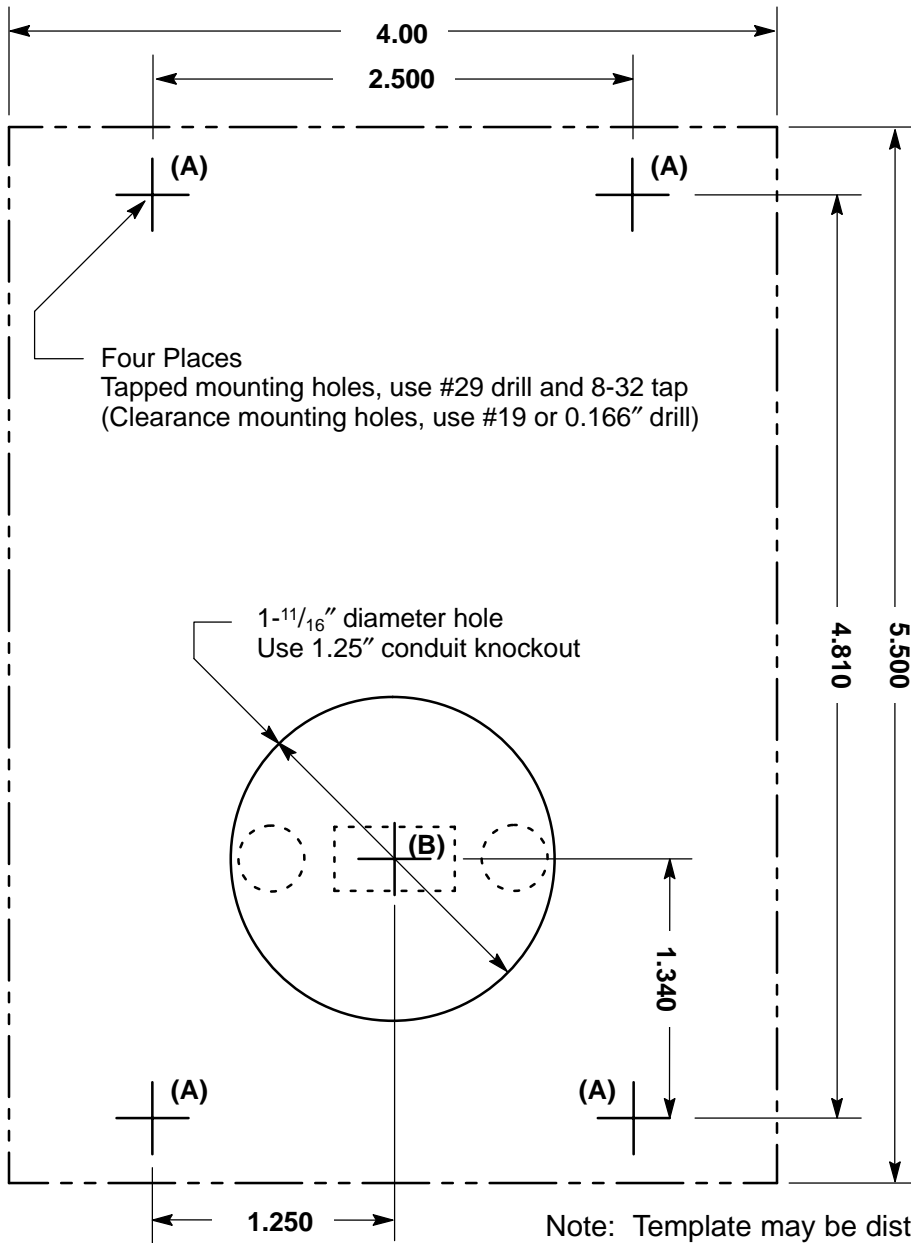
**Table B-2 Parameter Block Values Level 2** Continued

Level 2 Blocks - Continued					
Block Title	Parameter	P#	Adjustable Range	Factory	User Setting
COMMUNICATIONS	PROTOCOL	2801	0-RS-232 ASCII, 1-RS-485 ASCII, 2-RS-232 BBP, 3-RS-485 BBP	RS-485 ASCII	
	BAUD RATE	2802	0-9600, 1-19.2KB, 2-38.4KB, 3-57.6KB, 4-115.2KB, 5-230.4KB 6-460.8KB 7-921.6KB	9600	
	DRIVE ADDRESS	2803	0 - 31	0	
AUTO-TUNING	<b>CALC PRESETS</b>	2508	0-NO, 1-YES	NO	
	<b>CMD OFFSET TRM</b>	AU1	-	-	
	<b>CUR LOOP COMP</b>	AU2	-	-	
	<b>RESOLVER ALIGN</b>	AU3	-	-	
	<b>SPEED CNTRLR CALC</b>	AU4	-This procedure should be run with the motor loaded.	-	
LEVEL 1 BLOCK	Enters Level 1 Menu - See Table B-1.				
PRESS ENTER FOR PROGRAMMING EXIT	Exit programming mode and return to display mode.				

## Appendix C

---

## Remote Keypad Mounting Template





**BALDOR ELECTRIC COMPANY**  
**P.O. Box 2400**  
**Ft. Smith, AR 72902-2400**  
**(479) 646-4711**  
**Fax (479) 648-5792**

<b>CH</b> TEL: +41 52 647 4700 FAX: +41 52 659 2394	<b>D</b> TEL: +49 89 90 50 80 FAX: +49 89 90 50 8491	<b>UK</b> TEL: +44 1454 850000 FAX: +44 1454 850001	<b>F</b> TEL: +33 145 10 7902 FAX: +33 145 09 0864
<b>I</b> TEL: +39 11 562 4440 FAX: +39 11 562 5660	<b>AU</b> TEL: +61 29674 5455 FAX: +61 29674 2495	<b>CC</b> TEL: +65 744 2572 FAX: +65 747 1708	<b>MX</b> TEL: +52 477 761 2030 FAX: +52 477 761 2010

**M41A04**

**Series 23H AC Servo Control**

**MN723**