



---

---

---

# Series H2

# AC Closed Vector Control

**Installation & Operating Manual**



# Table of Contents

---

<b>Section 1</b>	
<b>Quick Start Guide</b> .....	1-1
<b>Section 2</b>	
<b>General Information</b> .....	2-1
CE Compliance .....	2-1
Overview .....	2-1
Limited Warranty .....	2-2
Safety Notice .....	2-3
<b>Section 3</b>	
<b>Receiving &amp; Installation</b> .....	3-1
Receiving & Inspection .....	3-1
Location and Mounting .....	3-1
Cover Removal .....	3-2
Control Installation .....	3-2
Power Conditioning .....	3-4
System Grounding .....	3-4
Line Impedance .....	3-5
Line Reactors .....	3-5
Load Reactors .....	3-5
Power Disconnect .....	3-6
Protective Devices .....	3-6
Reduced Input Voltage Derating .....	3-6
Electrical Installation .....	3-6
Optional Filter/Reactor .....	3-6
3 Phase Power and Motor Connections .....	3-8
Operating a Three Phase Control on Single Phase Input Power .....	3-9
Single Phase Control Derating .....	3-9
Single Phase Power and Motor Connections .....	3-11
M-Contactor .....	3-12
Optional Dynamic Brake Hardware .....	3-13
External Trip Input .....	3-13
Encoder Installation .....	3-13
Control Board Connections .....	3-14
Analog Inputs .....	3-15
Analog Outputs .....	3-16
Opto Isolated Inputs .....	3-16
Operating Modes .....	3-17
Keypad .....	3-17
Standard Run 2Wire .....	3-18
Standard Run 3Wire .....	3-19
15 Speed .....	3-20
Fan Pump 2Wire .....	3-21
Fan Pump 3Wire .....	3-22
Process Control .....	3-23
3 Speed Analog 2Wire .....	3-24
3 Speed Analog 3Wire .....	3-25
E-POT 2Wire .....	3-26
E-POT 3Wire .....	3-27
Network .....	3-28
Profile Run .....	3-29
Mint .....	3-30
Bipolar .....	3-31
Multiple Parameter Sets .....	3-32

Digital Outputs .....	3-33
Relay Outputs .....	3-33
USB Port .....	3-34
Communication Expansion Boards .....	3-35
Pre-Operation Checklist .....	3-35
Powerup Procedure .....	3-35
<b>Section 4</b>	
<b>Programming and Operation</b> .....	4-1
Overview .....	4-1
Status Display Mode .....	4-2
Menu Display .....	4-3
Quick Setup .....	4-4
Save Parameter Values .....	4-8
Restore Parameter Values .....	4-9
Programming .....	4-10
Event Log .....	4-11
Diagnostics .....	4-11
Display Options .....	4-13
Operating the Control from the Keypad .....	4-13
Accessing the Keypad JOG Command .....	4-13
Speed Adjustment using Local Speed Reference .....	4-14
<b>Section 5</b>	
<b>Troubleshooting</b> .....	5-1
Event Log .....	5-1
Diagnostics Information .....	5-6
Fault Messages .....	5-8
Electrical Noise Considerations .....	5-9
Relay and Contactor Coils .....	5-10
Wires between Controls and Motors .....	5-10
Special Drive Situations .....	5-10
Control Enclosures .....	5-10
Special Motor Considerations .....	5-10
Analog Signal Wires .....	5-10
<b>Section 6</b>	
<b>Manual Tuning the Series H2 Control</b> .....	6-1
<b>Section 7</b>	
<b>Specifications, Ratings &amp; Dimensions</b> .....	7-1
Specifications .....	7-1
Catalog Number Identification .....	7-4
Ratings .....	7-5
Terminal Tightening Torque Specifications .....	7-7
Mounting Dimensions .....	7-8
Size AA, B and C Controls .....	7-8
<b>Appendix A</b>	
<b>Optional Equipment</b> .....	A-1
Dynamic Braking (DB) Hardware .....	A-1
Keypad Extension Cable .....	A-1
Expansion Boards .....	A-2
<b>Appendix B</b> .....	B-1
Parameter Values .....	B-1
<b>Appendix C</b> .....	C-1
Remote Keypad Mounting Template .....	C-2

# Section 1

## Quick Start Guide

---

### Overview

If you are an experienced user of Baldor controls, you are probably already familiar with the keypad programming and keypad operation methods. If so, this quick start guide has been prepared for you. This procedure will help get your system up and running in the keypad mode quickly and allows motor and control operation to be verified. This procedure assumes that the Control, Motor and Dynamic Brake hardware are correctly installed (see Section 3 for procedures) and that you have an understanding of the keypad programming & operation procedures. Figure 1-1 shows minimum connection requirements. It is not necessary to wire the terminal strip to operate in the Keypad mode (Section 3 describes terminal strip wiring procedures). The quick start procedure is as follows:

1. Read the Safety Notice and Precautions in section 2 of this manual.
2. Mount the control. Refer to Section 3 "Physical Location" procedure.
3. Connect AC power, see Figure 1-1.
4. Connect the motor, see Figure 1-1.
5. Connect the encoder, refer to Section 3 "Encoder Installation".
6. Install Dynamic brake hardware, if required. Refer to Section 3 "Optional Dynamic Brake Hardware".

**Quick Start Checklist** Check of electrical items.

**CAUTION: After completing the installation but before you apply power, be sure to check the following items.**

1. Verify AC line voltage at source matches control rating.
2. Inspect all power connections for accuracy, workmanship and torques as well as compliance to codes.
3. Verify control and motor are grounded to each other and the control is connected to earth ground.
4. Check all signal wiring for accuracy.
5. Be certain all brake coils, contactors and relay coils have noise suppression. This should be an R-C filter for AC coils and reverse polarity diodes for DC coils. MOV type transient suppression is not adequate.

**WARNING: Make sure that unexpected operation of the motor shaft during start up will not cause injury to personnel or damage to equipment.**

### Quick Start Procedure

#### **Initial Conditions**

Be sure the Control, Motor and Dynamic Brake hardware are wired according to the procedures described in Section 3 of this manual. Become familiar with the keypad programming and keypad operation of the control as described in Section 4 of this manual.

1. Verify that any enable inputs to J2-8 are open.
2. Turn power on. Be sure there are no faults.
3. Enter the following motor data in the Level 2 Motor Data block parameters:
  - Motor Rated Volt (input)
  - Motor Rated Amps (FLA)
  - Motor Rated Speed (base speed)
  - Motor Rated Frequency
  - Motor Mag Amps (no load current)
  - Encoder Counts
  - Electrical Slip Frequency
4. Set the Level 2 Output Limits block, "OPERATING ZONE" parameter as desired (STD CONST TQ, STD VAR TQ, QUIET CONST TQ or QUIET VAR TQ).
5. If external dynamic brake hardware is used, set the Level 2 Brake Adjust block "Resistor Ohms" and "Resistor Watts" parameters.
6. In the Level 2 Motor Data block, find CALC MOTOR MODEL select YES (using the ▲ key) and let the control calculate preset values for the parameters that are necessary for control operation.
7. Go to Level 2 Auto Tune block, and select, "One Step Auto Tune".
  - a. 2901 ANALOG OFFSET TRIM
  - b. 2902 ONE STEP AUTO TUNE
8. Set the Level 2 Drive Limits block, "MIN OUTPUT SPEED" parameter.
9. Set the Level 2 Drive Limits block, "MAX OUTPUT SPEED" parameter.

#### **Check of Motors and Couplings**

1. Remove all power from the control.
2. Couple the motor to its load.
3. Verify freedom of motion of motor shaft.
4. Verify that motor coupling is tight without backlash.
5. Turn power on. Be sure no errors are displayed.
6. Run the drive from the keypad using one of the following: the arrow keys for direct speed control, a keypad entered speed or the JOG mode.
7. Select and program additional parameters to suit your application.

**Figure 1-1 Minimum Connection Diagram**

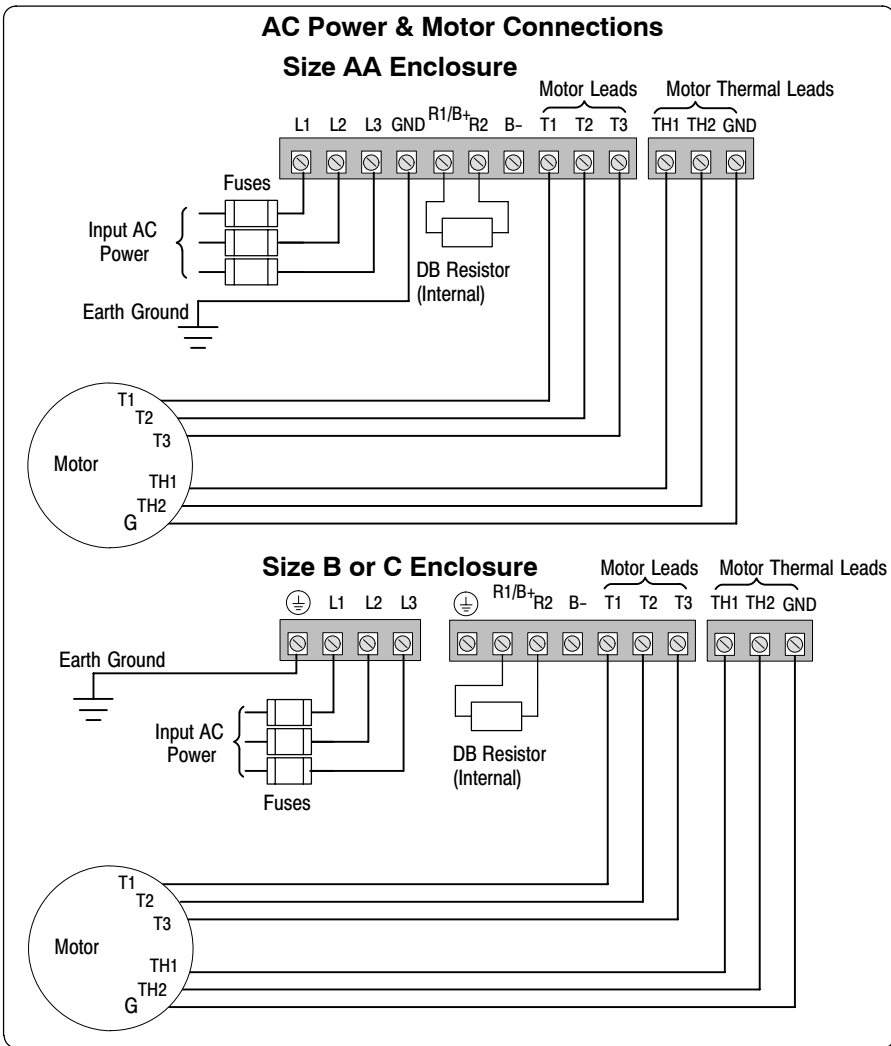
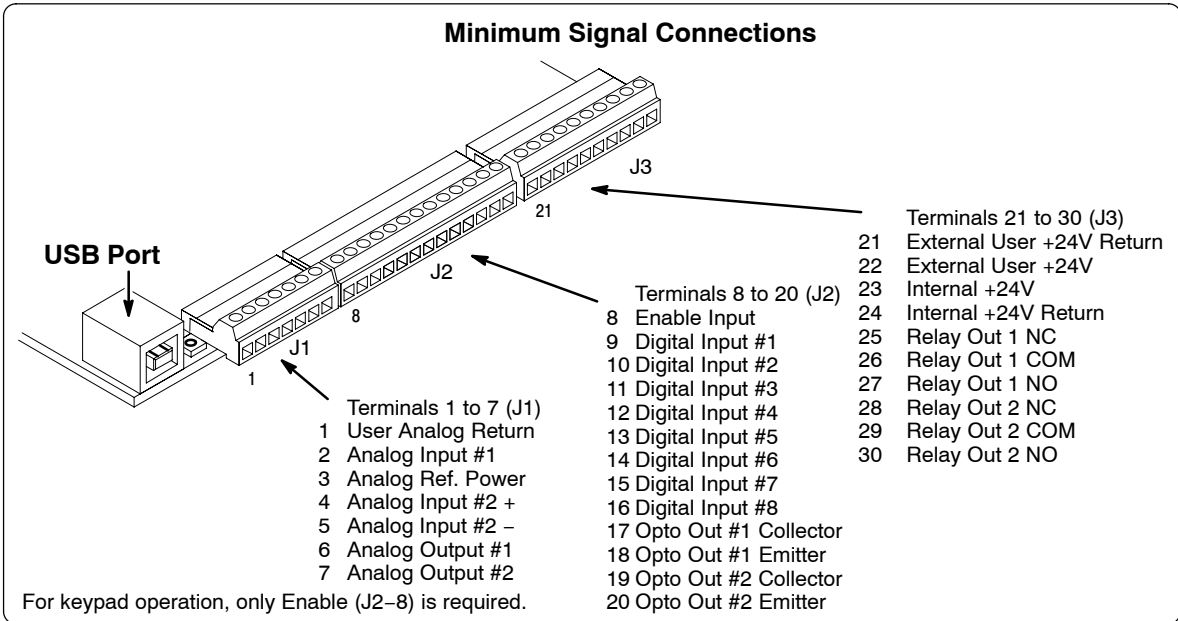

**Note:**  
The control enable input must be active to allow operation. Therefore, J2-8 Enable is connected by a factory installed jumper to J3-24. This uses the internal supply and provides an active low at J2-8.

See Recommended Tightening Torques in Section 7.

## Section 2

### General Information

---

#### **CE Compliance**

A custom unit may be required, contact Baldor. Compliance to Directive 89/336/EEC is the responsibility of the system integrator. A control, motor and all system components must have proper shielding grounding and filtering as described in MN1383. Please refer to MN1383 for installation techniques for CE compliance.

#### **Overview**

The Baldor Series H2 control uses flux vector technology. Flux vector technology (sometimes referred to as Field Oriented Control) is a closed loop control scheme using an algorithm to adjust the frequency and phase of voltage and current applied to a three phase induction motor. The vector control separates the motor current into its flux and torque producing components. These components are independently adjusted and vectorially added to maintain a 90 degree relationship between them. This produces maximum torque from base speed down to and including zero speed. Above base speed, the flux component is reduced for constant horsepower operation.

In addition to the current, the electrical frequency must also be controlled. The frequency of the voltage applied to the motor is calculated from the slip frequency and the mechanical speed of the rotor. This provides instantaneous adjustment of the voltage and current phasing in response to speed and position feedback from an encoder mounted to the motors' shaft.

The control's rated horsepower is based on the use of a NEMA design B four pole motor and 60Hz operation at nominal rated input voltage. If any other type of motor is used, the control should be sized to the motor using the rated current of the motor.

The control may be used in many different applications. It may be programmed by the user to operate in four different operating zones; standard or quiet and constant torque or variable torque. It can also be configured to operate in a number of modes depending upon the application requirements and user preference.

It is the responsibility of the user to determine the optimum operating zone and mode to interface the control to the application. These choices are made with the keypad as explained in Section 4 of this manual.

---

### **Limited Warranty**

For a period of two (2) years from the date of original purchase, BALDOR will repair or replace without charge controls and accessories which our examination proves to be defective in material or workmanship. This warranty is valid if the unit has not been tampered with by unauthorized persons, misused, abused, or improperly installed and has been used in accordance with the instructions and/or ratings supplied. This warranty is in lieu of any other warranty or guarantee expressed or implied. BALDOR shall not be held responsible for any expense (including installation and removal), inconvenience, or consequential damage, including injury to any person or property caused by items of our manufacture or sale. (Some states do not allow exclusion or limitation of incidental or consequential damages, so the above exclusion may not apply.) In any event, BALDOR's total liability, under all circumstances, shall not exceed the full purchase price of the control. Claims for purchase price refunds, repairs, or replacements must be referred to BALDOR with all pertinent data as to the defect, the date purchased, the task performed by the control, and the problem encountered. No liability is assumed for expendable items such as fuses.

Goods may be returned only with written notification including a BALDOR Return Authorization Number and any return shipments must be prepaid.



---

**Safety Notice**

This equipment contains voltages that may be as high as 1000 volts! Electrical shock can cause serious or fatal injury. Only qualified personnel should attempt the start-up procedure or troubleshoot this equipment.

This equipment may be connected to other machines that have rotating parts or parts that are driven by this equipment. Improper use can cause serious or fatal injury. Only qualified personnel should attempt the start-up procedure or troubleshoot this equipment.

**PRECAUTIONS**

- WARNING:** Do not touch any circuit board, power device or electrical connection before you first ensure that power has been disconnected and there is no high voltage present from this equipment or other equipment to which it is connected. Electrical shock can cause serious or fatal injury. Only qualified personnel should attempt the start-up procedure or troubleshoot this equipment.
- WARNING:** Be sure that you are completely familiar with the safe operation of this equipment. This equipment may be connected to other machines that have rotating parts or parts that are controlled by this equipment. Improper use can cause serious or fatal injury. Only qualified personnel should attempt the start-up procedure or troubleshoot this equipment.
- WARNING:** Do not use motor overload relays with an automatic reset feature. These are dangerous since the process may injure someone if a sudden or unexpected automatic restart occurs. If manual reset relays are not available, disable the automatic restart feature using external control wiring.
- WARNING:** This unit has an automatic restart feature that will start the motor whenever input power is applied and a RUN (FWD or REV) command is issued. If an automatic restart of the motor could cause injury to personnel, the automatic restart feature should be disabled by changing the Level 2 Miscellaneous block, Auto Restart parameter to Manual.
- WARNING:** Be sure the system is properly grounded before applying power. Do not apply AC power before you ensure that all grounding instructions have been followed. Electrical shock can cause serious or fatal injury.
- WARNING:** Do not remove cover for at least five (5) minutes after AC power is disconnected to allow capacitors to discharge. Dangerous voltages are present inside the equipment. Electrical shock can cause serious or fatal injury.
- WARNING:** Improper operation of control may cause violent motion of the motor shaft and driven equipment. Be certain that unexpected motor shaft movement will not cause injury to personnel or damage to equipment. Certain failure modes of the control can produce peak torque of several times the rated motor torque.
- WARNING:** Motor circuit may have high voltage present whenever AC power is applied, even when motor is not rotating. Electrical shock can cause serious or fatal injury.
- WARNING:** Dynamic brake resistors may generate enough heat to ignite combustible materials. Keep all combustible materials and flammable vapors away from brake resistors.
- WARNING:** The motor shaft will rotate during the autotune procedure. Be certain that unexpected motor shaft movement will not cause injury to personnel or damage to equipment.

Continued on next page

---

**Caution:** Disconnect motor leads (T1, T2 and T3) from control before you perform a “Megger” test on the motor. Failure to disconnect motor from the control will result in extensive damage to the control. The control is tested at the factory for high voltage / leakage resistance as part of Underwriter Laboratory requirements.

**Caution:** Suitable for use on a circuit capable of delivering not more than the RMS symmetrical short circuit amperes listed here at rated voltage.

<u>Horsepower</u>	<u>RMS Symmetrical Amperes</u>
1-50	5,000
51-200	10,000
201-400	18,000
401-600	30,000
601-900	42,000

**Caution:** Do not connect AC power to the Motor terminals T1, T2 and T3. Connecting AC power to these terminals may result in damage to the control.

**Caution:** Baldor recommends not to use “Grounded Leg Delta” transformer power leads that may create ground loops. Instead, we recommend using a four wire Wye.

**Caution:** Do not supply any power to the External Trip (motor thermostat) leads at TH1 and TH2. Power on these leads can damage the control. Use a dry contact type that requires no external power to operate.

**Caution:** If the DB hardware mounting is in any position other than vertical, the DB hardware must be derated by 35% of its rated capacity.

**Caution:** Do not connect any shields to the encoder case or motor frame. The encoder +5VDC supply at pins 8 and 9 of the encoder board is referenced to circuit board common. Do not connect any shields to ground or another power supply or damage to the control may result.

**Caution:** Before external Dynamic Brake Hardware is added, the internal resistor must be disconnected. Remove the resistor from the B+/R1 and R2 terminals. The external resistor can be connected across these terminals. Failure to remove the internal resistor will decrease the total resistance (parallel connection) and cause damage.

**Caution:** Do not set Level 2, Drive Configure, Power Input parameter to Common Bus if AC power is connected to L1, L2 or L3. Common Bus requires numerous changes, contact Baldor for information.

## Section 3 Receiving & Installation

### Receiving & Inspection

When you receive your control, there are several things you should do immediately.

1. Observe the condition of the shipping container and report any damage immediately to the commercial carrier that delivered your control.
2. Remove the control from the shipping container and remove all packing materials from the control. The container and packing materials may be retained for future shipment.
3. Verify that the part number of the control you received is the same as the part number listed on your purchase order.
4. Inspect the control for external physical damage that may have been sustained during shipment and report any damage immediately to the commercial carrier that delivered your control.
5. If the control is to be stored for several weeks before use, be sure that it is stored in a location that conforms to published storage humidity and temperature specifications stated in this manual.

### Location and Mounting

The control should be installed in an area that is protected from direct sunlight, corrosives, harmful gases or liquids, dust, metallic particles, and vibration. Exposure to these can reduce the operating life and degrade performance of the control.

Several other factors should be carefully evaluated when selecting a location for installation:

1. To maintain compliance with European Electrical Safety Standard VDE0160(1994)/EN50178 (1998) the control must be mounted inside an enclosure that requires a tool for opening.
2. The enclosure should provide 15dB attenuation to radiated emissions between 30–100MHz.
3. For effective cooling and maintenance, mount the drive vertically on a solid, flat, non-flammable, vertical surface. See Dimensions in Section 7 of this manual.
4. Be sure to provide proper top, bottom and side clearance (each side).
5. **Operating Altitude derating.** Up to 3300 feet (1000 meters) no derating required. Derate the continuous and peak output current by 2% for each 330 feet (100 meters) above 3300 feet. Maximum operating altitude 16,500 feet (5,000 meters).
6. **Operating Temperature derating.** –10°C to 45°C ambient. 45°C maximum, no derating. Derate the continuous and peak output current by 3% for each degree above 45°C to 55°C maximum ambient.

**Table 3-1 Watts Loss Ratings**

Enclosure Size	240VAC		480VAC		600VAC	
	2.5kHz PWM	8.0kHz PWM	2.5kHz PWM	8.0kHz PWM	2.5kHz PWM	8.0kHz PWM
AA, B and C	14 Watts/ Amp	17 Watts/ Amp	17 Watts/ Amp	26 Watts/ Amp	18 Watts/ Amp	28 Watts/ Amp

## Cover Removal

Size AA, B and C

To connect power and signal wires, the cover must be removed. This procedure describes how to access all terminal connections inside the control.

1. Remove the four cover screws shown in Figure 3-1.
2. Lift and remove the cover.
3. Press in the two Cover Releases (Controller) and rotate the controller cover open as shown.

**Figure 3-1 Size AA, B and C Cover Removal**

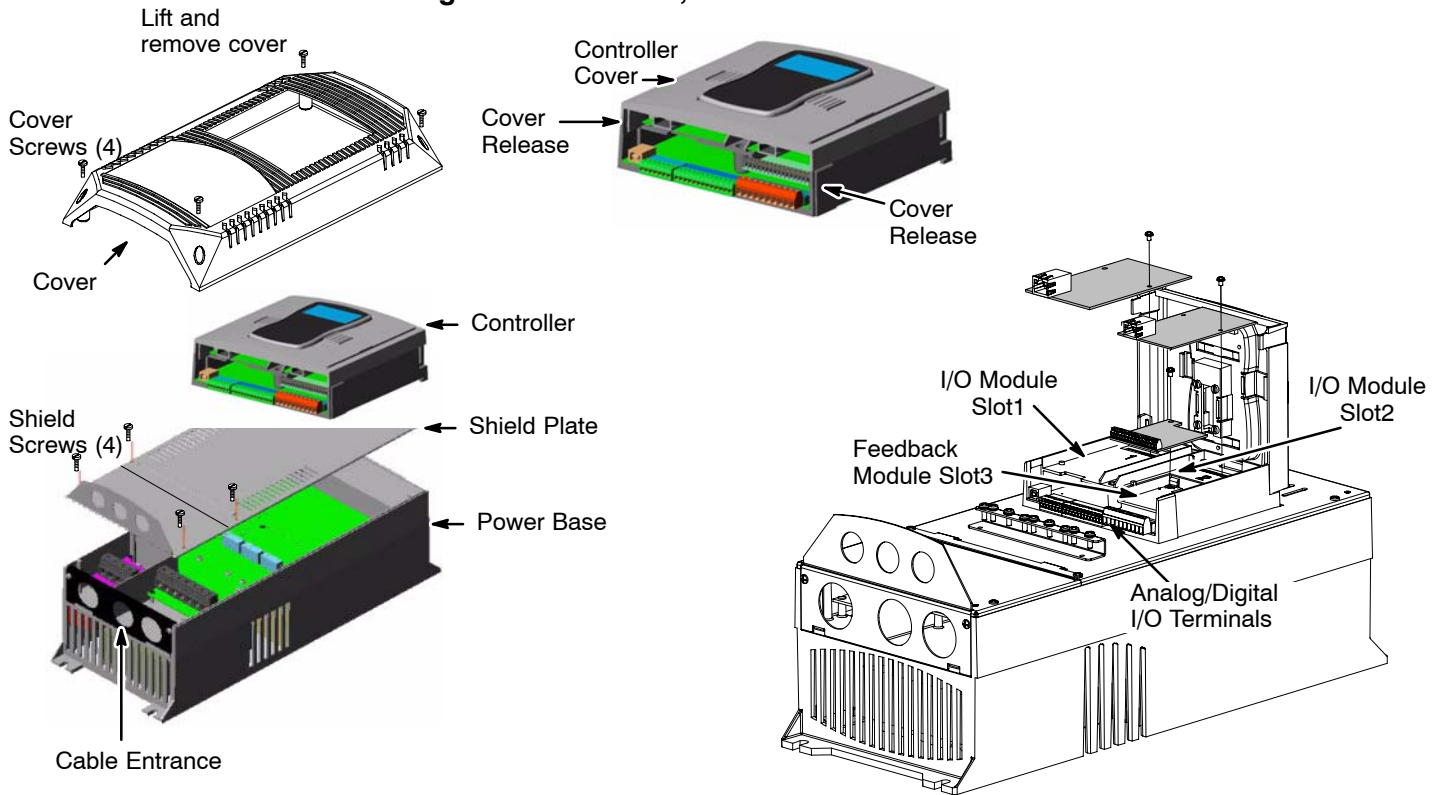

## Control Installation

The control must be securely fastened to the mounting surface at the mounting holes.

### Shock Mounting

If the control will be subjected to levels of shock greater than 1G or vibration greater than 0.5G at 10 to 60Hz, the control should be shock mounted.

**Keypad Connector** The keypad connector referenced in Table 3-2 is an RJ11 type wired as half duplex RS485.

**Table 3-2 Cable Connections**

Pin	Signal Name	Description
1	A	RS485 Line A
2	B	RS485 Line B
3	KP_PS_GND	Power Supply Return
4	+8V	Power Supply +
5	KP_PS_GND	Power Supply Return
6	+8V	Power Supply +

**Optional Remote Keypad Installation**

The keypad may be remotely mounted using optional Baldor keypad extension cable (refer to Appendix A). When the keypad is properly mounted to a NEMA Type 4X enclosure, it retains the Type 4X rating. The Mounting/Drill Template is located in Appendix C of this manual.

**Tools Required:**

- Center punch, tap handle, screwdrivers (Phillips and straight).
- #27 drill bit.
- 1-3/8" standard knockout punch.
- RTV sealant.

**Mounting Instructions:** For clearance mounting holes

1. Locate a flat 4" wide x 5.5" minimum high mounting surface. Material should be sufficient thickness (14 gauge minimum).
2. Place the template on the mounting surface or mark the holes as shown on the template.
3. Accurately center punch the 3 mounting holes and the large knockout.
4. Drill three #27 clearance holes.
5. Locate the 1-3/8" knockout center and punch using the manufacturers instructions.
6. Debur knockout and mounting holes making sure the panel stays clean and flat.
7. Apply RTV to the three #27 clearance holes.
8. Assemble the keypad to the panel. Use 8-32 screws, nuts and lock washers.
9. From the inside of the panel, apply RTV over each of the four mounting screws and nuts. Cover a 3/4" area around each screw while making sure to completely encapsulate the nut and washer.
10. Route the keypad cable into the control and connect to P2 of the control board, Figure 3-2.

**Figure 3-2 Connector Locations**

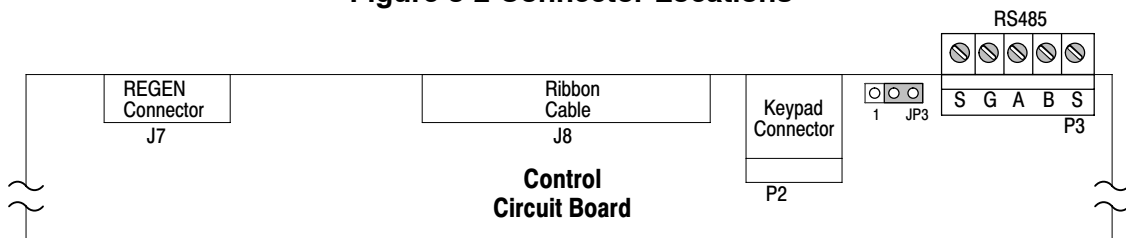

## Power Conditioning System Grounding

Baldor recommends not using “Grounded Leg Delta” transformer power leads that may create ground loops. Instead, we recommend using a four wire Wye. Baldor Controls are designed to be powered from standard three phase lines that are electrically symmetrical with respect to ground. System grounding is an important step in the overall installation to prevent problems. The recommended grounding method is shown in Figure 3-3.

**Figure 3-3 Recommended System Grounding**

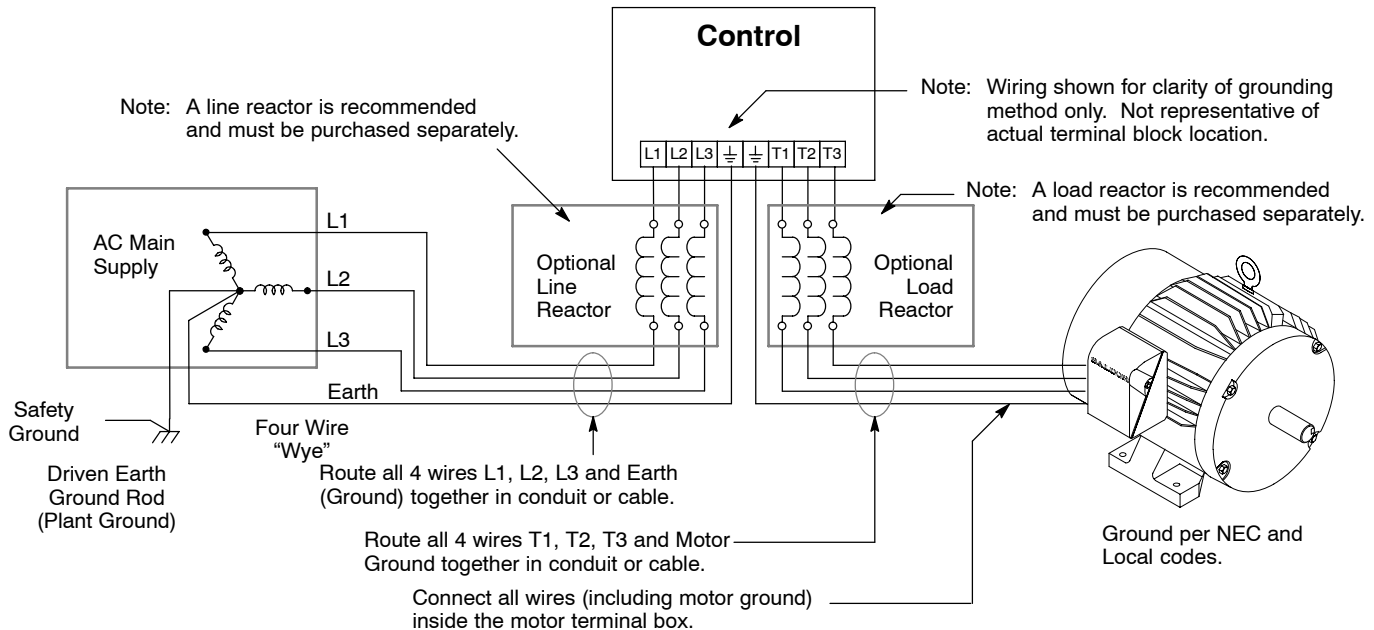

Baldor Controls are designed to be powered from standard three phase power lines that are electrically symmetrical with respect to ground. System grounding is an important step in the overall installation to prevent problems. A four wire WYE connection is recommended.

### Ungrounded Distribution System

With an ungrounded power distribution system it is possible to have a continuous current path to ground through the MOV devices. To avoid equipment damage, an isolation transformer with a WYE grounded secondary is recommended. This provides three phase AC power that is symmetrical with respect to ground.

### Input Power Conditioning

Baldor controls are designed for direct connection to standard three phase lines that are electrically symmetrical with respect to ground. An AC line reactor or an isolation transformer may be required for some power conditions.

- If the feeder or branch circuit that provides power to the control has permanently connected power factor correction capacitors, an input AC line reactor or an isolation transformer must be connected between the power factor correction capacitors and the control.
- If the feeder or branch circuit that provides power to the control has power factor correction capacitors that are switched on line and off line, the capacitors must not be switched while the control is connected to the AC power line. If the capacitors are switched on line while the control is still connected to the AC power line, additional protection is required. TVSS (Transient Voltage Surge Suppressor) of the proper rating must be installed between the AC line reactor or an isolation transformer and the AC input to the control.

**Line Impedance** The Baldor control requires a 1% line impedance minimum. If the impedance of the incoming power does not meet the requirement for the control, a 3 phase line reactor can be used to provide the needed impedance in most cases. The input impedance of the power lines can be determined as follows:

Measure the line to line voltage at no load and at full rated load.  
Use these measured values to calculate impedance as follows:

$$\% \text{Impedance} = \frac{(\text{Volts}_{\text{No Load}} - \text{Volts}_{\text{Full Load}})}{(\text{Volts}_{\text{No Load}})} \times 100$$

**Line Reactors** Three phase line reactors are available from Baldor. The line reactor to order is based on the full load current of the motor (FLA). If providing your own line reactor, use the following formula to calculate the minimum inductance required. Size B and C controls include built-in Line Reactors.

$$L = \frac{(V_{L-L} \times 0.01)}{(I \times \sqrt{3} \times 377)}$$

Where: L Minimum inductance in Henries.  
 $V_{L-L}$  Input volts measured line to line.  
 0.01 Desired percentage of input impedance 1%.  
 I Input current rating of control.  
 377 Constant used with 60Hz power.  
 Use 314 if input power is 50Hz.

**Table 3-3 Recommended Baldor Line Reactor**

Size	HP	240VAC 60/50Hz	480VAC 60/50Hz	600VAC 60/50Hz
AA	1	LRAC00401	LRAC00201	LRAC00202
AA	2	LRAC00801	LRAC00402	LRAC00403
AA	3	LRAC01201	LRAC00402	LRAC00803
AA	5	LRAC01801	LRAC00802	LRAC00802
AA	7.5	LRAC02501	LRAC01202	LRAC01202

**Load Reactors** Line reactors may be used at the control output to the motor. When used this way, they are called Load Reactors. Load reactors serve several functions that include:

- Protect the control from a short circuit at the motor.
- Limit the rate of rise of motor surge currents.
- Slowing the rate of change of power the control delivers to the motor.

Load reactors should be installed as close to the control as possible. Selection should be based on the motor nameplate FLA value.

**Power Disconnect** A power disconnect should be installed between the input power service and the control for a fail safe method to disconnect power. The control will remain in a powered-up condition until all input power is removed from the control and the internal bus voltage is depleted.

**Protective Devices** Recommended fuse sizes are based on the following:  
 115% of maximum continuous current for time delay.  
 150% of maximum continuous current for Fast or Very Fast action.

Note: These recommendations do not consider harmonic currents or ambient temperatures greater than 45°C. Be sure a suitable input power protection device is installed. Use the recommended fuses and wire sizes shown in Table 3-5 is based on the use of copper conductor wire rated at 75 °C. The table is specified for NEMA B motors.

Fast Action Fuses:	240VAC, Buss® KTN 480VAC, Buss® KTS to 600A (KTU for 601 to 1200A) 600VAC, Buss® KTS to 600A (KTU for 601 to 1200A)
Very Fast Action:	240VAC, Buss® JJN 480VAC, Buss® JJS 600VAC, Buss® JJS
Semiconductor Fuses:	240VAC, Ferraz Shawmut A50QS 480VAC, Ferraz Shawmut A70QS 600VAC, Ferraz Shawmut A70QS

Buss® is a trademarks of Cooper Industries, Inc.

**Reduced Input Voltage Derating** Power ratings are for nominal AC input voltages (240 or 480VAC). The power rating of the control must be reduced when operating at a reduced input voltage. The amount of reduction is the ratio of the voltage change.

**Examples:**

A 5hp, 240VAC control operating at 208VAC has an effective power rating of 4.33hp.

$$5HP \times \frac{208VAC}{240VAC} = 4.33hp$$

Likewise, a 3hp, 480VAC control operating at 380VAC has an effective power rating of 2.37hp.

$$3HP \times \frac{380VAC}{480VAC} = 2.37hp$$

**Electrical Installation** All interconnection wires between the control, AC power source, motor, host control and any operator interface stations should be in metal conduits or shielded cable must be used. Use listed closed loop connectors that are of appropriate size for wire gauge being used. Connectors are to be installed using crimp tool specified by the manufacturer of the connector. Only class 1 wiring should be used.

**Table 3-4 Cable Entrance Hole Sizes**

Control Size	Hole Sizes Provided	
	American NPT Size	Metric Size
AA	1/2	(22.8mm) M20, PG16
B	1/2	(22.8mm) M20, PG16
C	1/2	(22.8mm) M20, PG16
	3/4	(28.6mm) M25, PG21

**Optional Filter/Reactor** Figure 3-4 shows the connections for installing an optional Line Filter and AC Reactor.

**Figure 3-4 Filter and Reactor Connections**

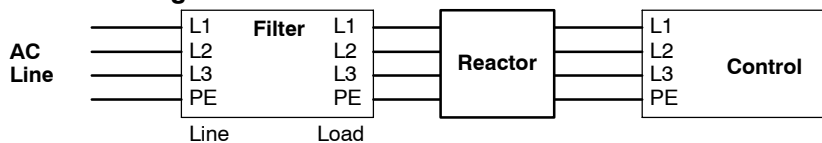



**Table 3-5 240VAC Three Phase Wire Size**

Control Rating		Input Fuse (Amps)		Wire Gauge	
Input Amps	HP	Fast Acting (UL)	Fast Acting (CUL)	AWG	mm <sup>2</sup>
4.2	1	6	6	14	2.5
7.0	2	12	12	14	2.5
10	3	15	15	14	2.5
16	5	25	25	12	4.0
22	7.5	35	35	10	6.0
66	25	110	*A50QS125-4	4	25.0
78	30	125	*A50QS150-4	3	35.0
102	40	175	*A50QS150-4	1	50.0
134	50	175	*A50QS150-4	1/0	50.0

\*Requires custom drive for CUL application using Ferraz Shawmut semiconductor fuses.

Note: All wire sizes are based on 75°C copper wire. Recommended fuses are based on 45°C ambient, maximum continuous control output current and no harmonic current.

**Table 3-6 480VAC Three Phase Wire Size**

Control Rating		Input Fuse (Amps)		Wire Gauge	
Input Amps	HP	Fast Acting (UL)	Fast Acting (CUL)	AWG	mm <sup>2</sup>
2.1	1	3	3	14	2.5
3.4	2	6	6	14	2.5
4.8	3	8	8	14	2.5
7.6	5	12	12	14	2.5
11	7.5	17.5	17.5	14	2.5
41	30	60	*A70QS60-4	8	10.0
54	40	80	*A70QS80-4	6	16.0
67	50	100	*A70QS100-4	4	25.0

\*Requires custom drive for CUL application using Ferraz Shawmut semiconductor fuses.

Note: All wire sizes are based on 75°C copper wire. Recommended fuses are based on 45°C ambient, maximum continuous control output current and no harmonic current.

**Table 3-7 600VAC Three Phase Wire Size**

Control Rating		Input Fuse (Amps)		Wire Gauge	
Input Amps	HP	Fast Acting (UL)	Fast Acting (CUL)	AWG	mm <sup>2</sup>
1.7	1	4	4	14	2.5
2.7	2	6	6	14	2.5
3.9	3	10	10	14	2.5
6.1	5	15	15	14	2.5
9.0	7.5	17.5	17.5	14	2.5
28	25	40	*A70QS40-4	10	6.0
33	30	50	*A70QS50-4	8	10.0
42	40	70	*A70QS70-4	6	16.0
56	50	80	*A70QS80-4	6	16.0

\*Requires custom drive for CUL application using Ferraz Shawmut semiconductor fuses.

Note: All wire sizes are based on 75°C copper wire. Recommended fuses are based on 45°C ambient, maximum continuous control output current and no harmonic current.

### 3 Phase Power and Motor Connections

Figure 3-5 shows the minimum connections required at the power connector. All cables must be shielded and the shields must be grounded at the cable entrance. The brake resistor and cable must be shielded if installed outside the enclosure.

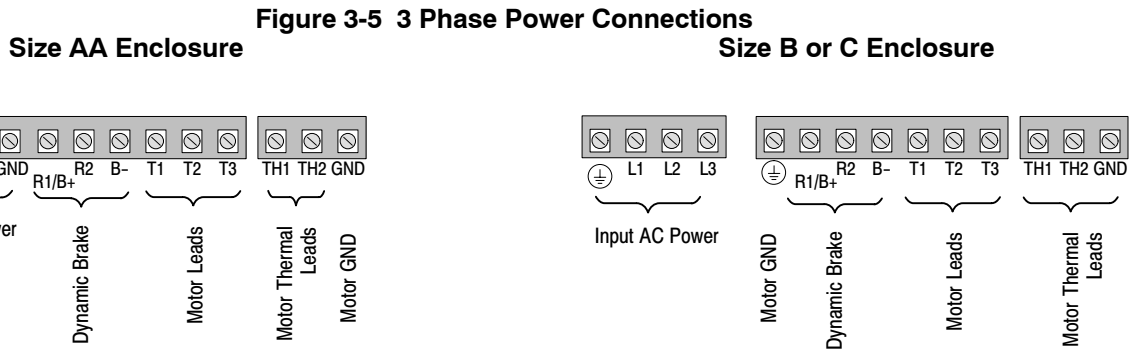

See Recommended Tightening Torques in Section 7.

1. Access the Power and Motor Terminals (see Cover Removal procedure).
2. Feed the power supply and motor cables into the drive through the cable entrance.
3. Connect the line L1, L2, L3 and GND to the power terminal connectors, Figure 3-6.
4. Connect motor leads to T1, T2, T3 and GND motor terminal connectors.

**Figure 3-6 3 Phase Power Connections**

\* Optional components not provided with control.

Notes:

1. See "Protective Devices" described previously in this section.
2. Use same gauge wire for Earth ground as is used for L1, L2 and L3.
3. Metal conduit should be used. Connect conduits so the use of a Reactor or RC Device does not interrupt EMI/RFI shielding.
4. See Line/Load Reactors described previously in this section. Line Reactors are built-in for size B and C controls.

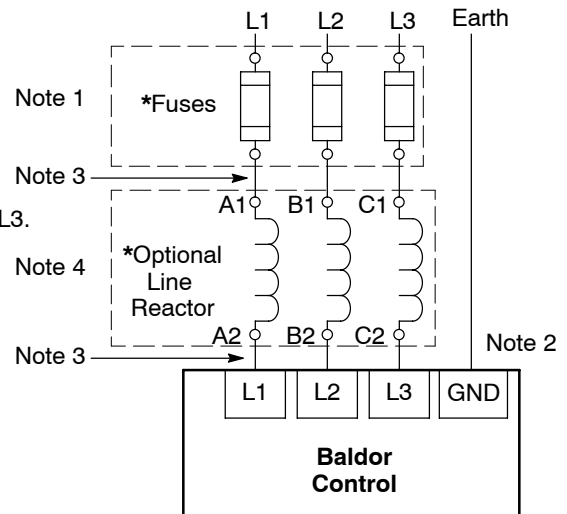

See Recommended Tightening Torques in Section 7.

### Operating a Three Phase Control on Single Phase Input Power

Single phase AC input power can be used to power the control instead of three phase for control sizes AA, B and C. The specifications and control sizes are listed in Section 7 of this manual. If single phase power is to be used, the rated Horsepower of the control may have to be reduced (derated). In addition, power wiring and jumper changes are required. Both connection types are shown in Figure 3-7.

Single phase rating wire size and protection devices are listed in Tables 3-8 and 3-9.

**Single Phase Control Derating:** Single phase power derating requires that the continuous and peak current ratings of the control be reduced by the following percentages:

1. **1-7.5 hp 240 and 480VAC controls:**  
Derate output hp to the next lower hp value (ie 7.5hp becomes 5hp etc.)
2. **10-50 hp 240 and 480VAC controls:**  
Derate output hp by 50% of the nameplate rating.

**Table 3-8 Single Phase Wire Size and Protection Devices - 240 VAC Controls**

Single Phase Input		Input Fuse (Amps) Fast Acting	Wire Gauge	
Input Amps	HP		AWG	mm <sup>2</sup>
8.0	1	12	14	2.5
10	2	15	14	2.5
15	3	25	12	4.0
28	5	45	10	6.0
40	7.5	60	8	10.0
50	10	80	6	16.0
68	15	110	4	25.0
88	20	150	3	35.0
110	25	175	2	35.0
136	30	200	1/0	50.0
176	40	250	3/0	95.0
216	50	350	(2) 1/0	(2) 50.0

Note: All wire sizes are based on 75°C copper wire. Recommended fuses are based on 45°C ambient, maximum continuous control output current and no harmonic current.

**Table 3-9 Single Phase Wire Size and Protection Devices - 480 VAC Controls**

Single Phase Input		Input Fuse (Amps) Fast Acting	Wire Gauge	
Input Amps	HP		AWG	mm <sup>2</sup>
4.0	1	5	14	2.5
6.0	2	8	14	2.5
8.5	3	12	14	2.5
14	5	20	12	4.0
20	7.5	30	10	6.0
25	10	40	10	6.0
34	15	50	8	10.0
44	20	70	8	10.0
55	25	80	6	16.0
68	30	100	4	25.0
88	40	150	3	35.0
108	50	175	2	35.0

Note: All wire sizes are based on 75°C copper wire. Recommended fuses are based on 45°C ambient, maximum continuous control output current and no harmonic current.

**Figure 3-7 Size AA, B and C Single Phase Power Connections**  
**Single phase 3 wire Connections**      **Single phase 2 Wire Connections**

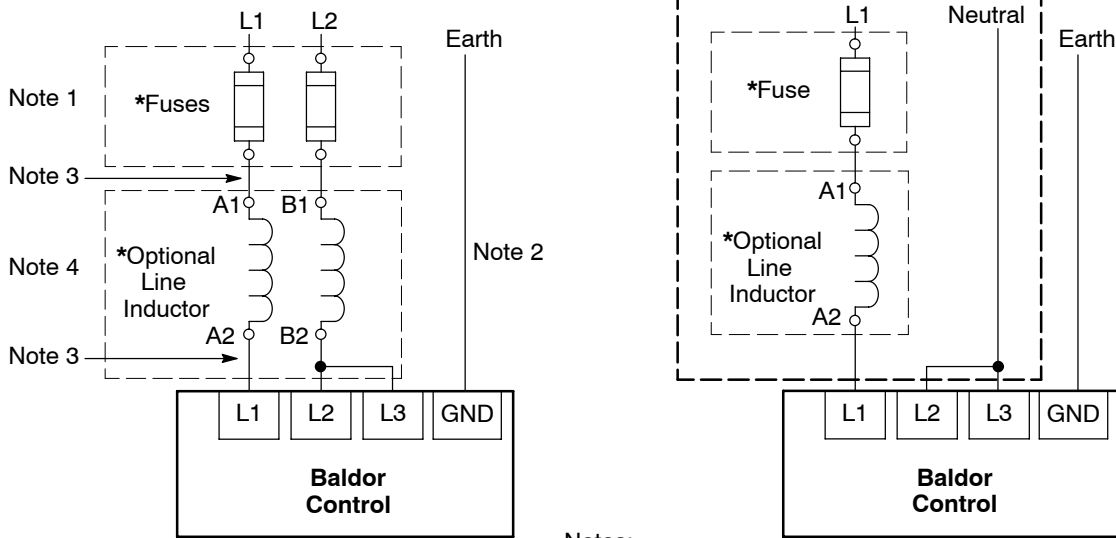

\* Optional components not provided with size AA control.

Notes:

1. See "Protective Devices" described previously in this section.
2. Use same gauge wire for Earth ground as is used for L1, L2 and L3.
3. Metal conduit should be used. Connect conduits so the use of a Reactor or RC Device does not interrupt EMI/RFI shielding.
4. See Line/Load Reactors described previously in this section. Line Reactors are built-in for size B and C controls.

See Recommended Tightening Torques in Section 7.

## Single Phase Power and Motor Connections ZHH6XX-XX

Figure 3-8 shows the minimum connections required at the power connector. All cables must be shielded and the shields must be grounded at the cable entrance. The brake resistor and cable must be shielded if installed outside the enclosure.

**Figure 3-8 Single Phase Control Power Terminals  
Size AA Enclosure**

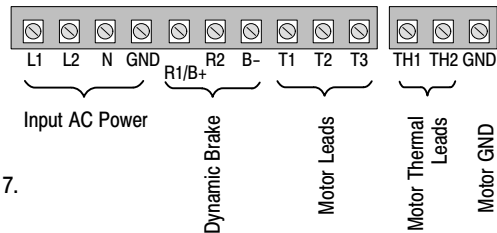

See Recommended Tightening Torques in Section 7.

1. Access the Power and Motor Terminals (see Cover Removal procedure).
2. Feed the power supply and motor cables into the drive through the cable entrance.
3. Connect the line L1, L2, L3 and GND to the power terminal connectors, Figure 3-6.
5. Connect motor leads to T1, T2, T3 and GND motor terminal connectors.

**Figure 3-9 Single Phase Control Power Connections**  
120VAC Single Phase

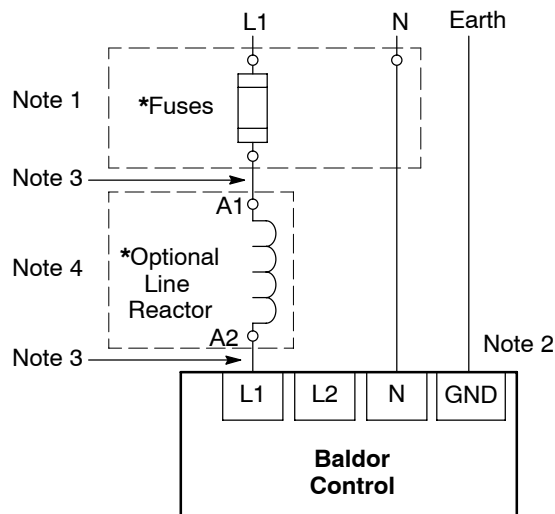

240VAC Single Phase

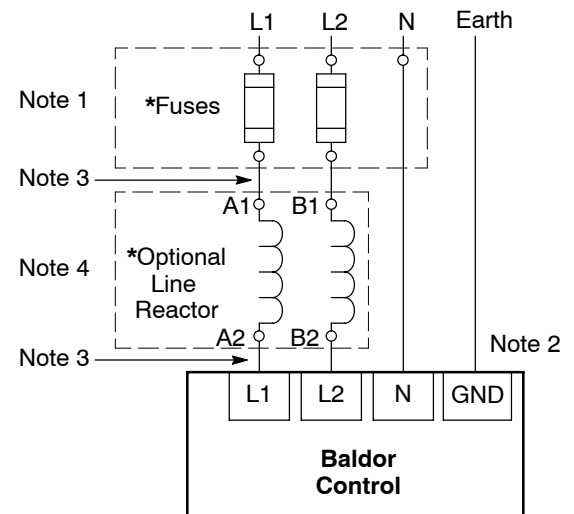

\* Optional components not provided with control.

Notes:

1. See Table 3-10.
2. Use same gauge wire for Earth ground as is used for L1, L2 and N.
3. Metal conduit should be used. Connect conduits so the use of a Reactor or RC Device does not interrupt EMI/RFI shielding.
4. See Line/Load Reactors described previously in this section. Line Reactors are built-in for size B and C controls.

See Recommended Tightening Torques in Section 7.

**Table 3-10 Single Phase Rating Wire Size and Protection Devices - 240 VAC Controls**

Single Phase Input		Input Fuse (Amps) Fast Acting	Wire Gauge	
Input Amps	HP		AWG	mm <sup>2</sup>
6.8	1	12	14	2.5
9.6	2	15	14	2.5
15.2	3	25	12	4.0

Note: All wire sizes are based on 75°C copper wire. Recommended fuses are based on 45°C ambient, maximum continuous control output current and no harmonic current.

**M-Contactor**

If required by local codes or for safety reasons, an M-Contactor (motor circuit contactor) may be installed. However, incorrect installation or failure of the M-contactor or wiring may damage the control. If an M-Contactor is installed, the control must be disabled for at least 200msec before the M-Contactor is opened or the control may be damaged. M-Contactor connections are shown in Figure 3-10.

**Caution:** If an M-Contactor is installed, the control must be disabled for at least 200msec before the M-Contactor is opened. If the M-Contactor is opened while the control is supplying voltage and current to the motor, the control may be damaged. Before the control is enabled, the M-Contactor must be closed for at least 200msec before the control is enabled.

**Figure 3-10 Motor Connections and Optional Connections**

\* Optional components not provided with control.

Notes:

1. Metal conduit should be used. Connect conduits so the use of Load Reactor or RC Device does not interrupt EMI/RFI shielding.
2. See Line/Load Reactors described previously in this section.
3. Use same gauge wire for ground as for T1, T2 and T3.

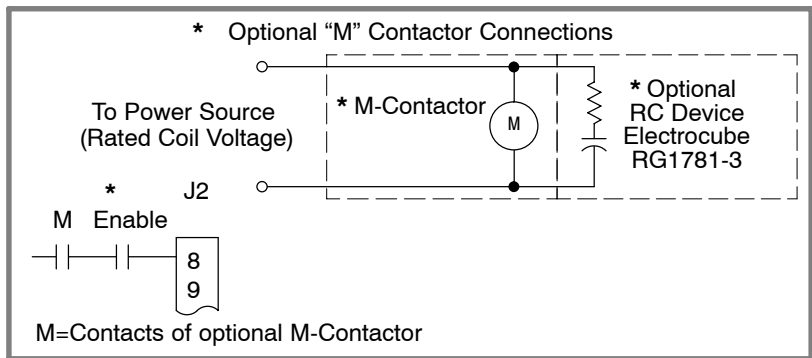
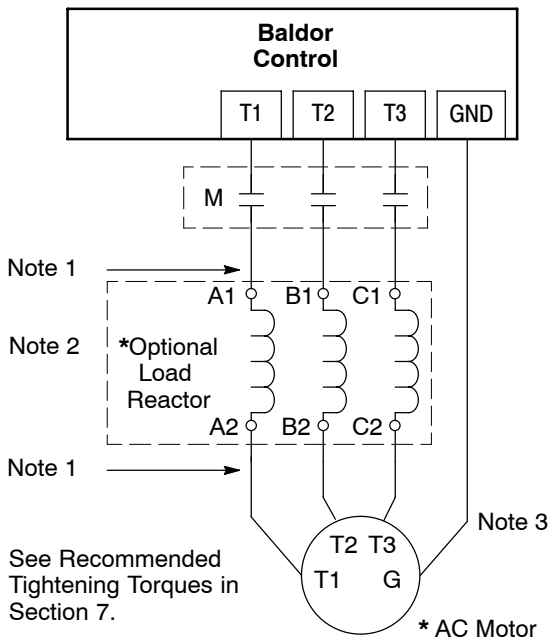

## Optional Dynamic Brake Hardware

Size AA, B and C controls, refer to Figure 3-11 for DB resistor connections.

Dynamic Brake (DB) Hardware must be installed on a flat, non-flammable, vertical surface for effective cooling and operation.

**Caution:** Before external Dynamic Brake Hardware is added, the internal resistor must be disconnected. Remove the resistor from the B+/R1 and R2 terminals. The external resistor can be connected across these terminals. Failure to remove the internal resistor will decrease the total resistance (parallel connection) and cause damage.

**Electrical Installation** Connections for DB hardware are determined by the Control model number suffix (E, EO, M or MO).

### Figure 3-11 DB Terminal Identification

“E” or “W” suffix



R1/B+ R2 B-

Internal Dynamic Brake resistor for size AA, B & C controls must be removed before external resistor hardware is installed.

**C Size Only – Disconnect internal DB resistor wires from DBR1 and DBR2 terminals before connecting external DB Resistor to prevent damage.**

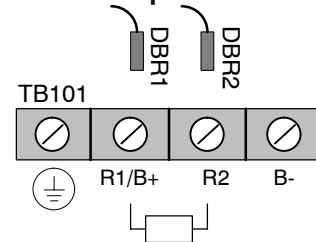

See recommended Terminal Tightening Torques in Section 7.

**Note:** Although not shown, metal conduit should be used to shield all power wires and motor leads.

**External Trip Input** Terminal J2-16 is available for connection to a normally closed contact. The contact should be a dry contact type with no power available from the contact. When the contact opens (activated), the control will automatically shut down and give an External Trip fault.

## Encoder Installation

The Encoder Board is installed in the Feedback Module Slot 3 shown in Figure 3-1.

Encoder connections are made at that board (see Figure 3-12). Use 16AWG (1.31mm<sup>2</sup>) maximum.

### Figure 3-12 Encoder Connections

J1 selects the power source for the encoder.

J1 Pins Power Source

1-2 5VDC  
2-3 12VDC

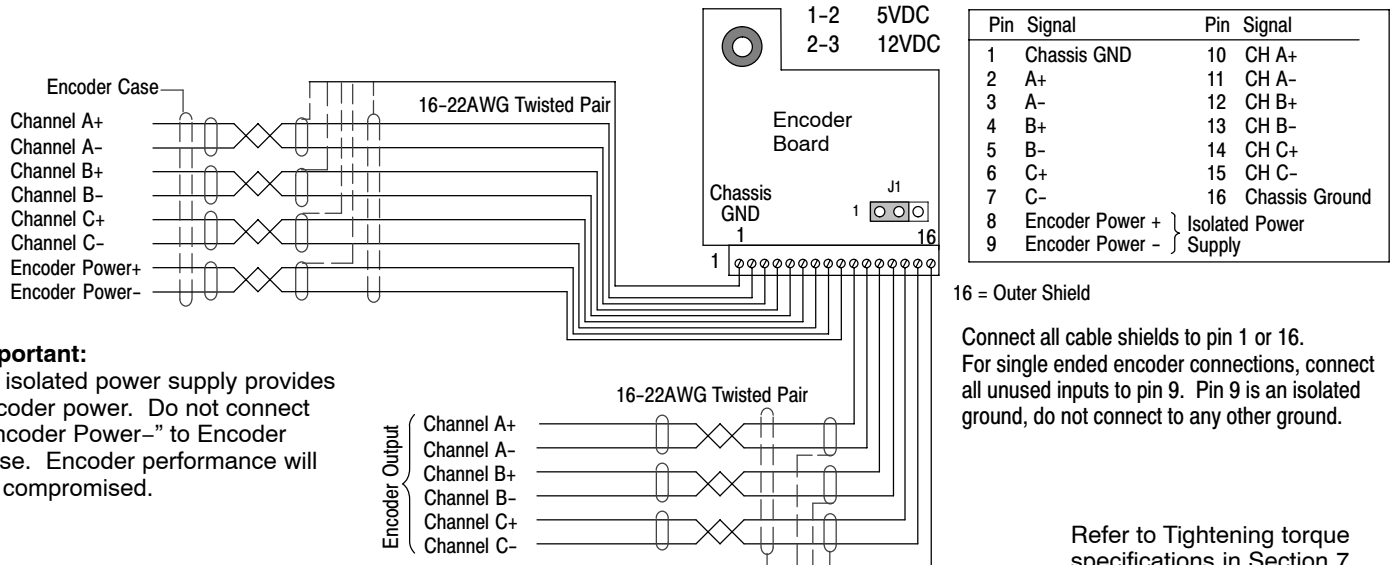

#### Important:

An isolated power supply provides encoder power. Do not connect “Encoder Power-” to Encoder Case. Encoder performance will be compromised.

Refer to Tightening torque specifications in Section 7.

## Control Board Connections

The analog and digital inputs and output terminals are shown in Figure 3-13. The signals are described in Tables 3-11, 3-12 and 3-13. Connections will depend upon which of the operating modes are chosen. Each mode is described and a connection diagram is provided later in this section.

**Figure 3-13 Control I/O Connections**

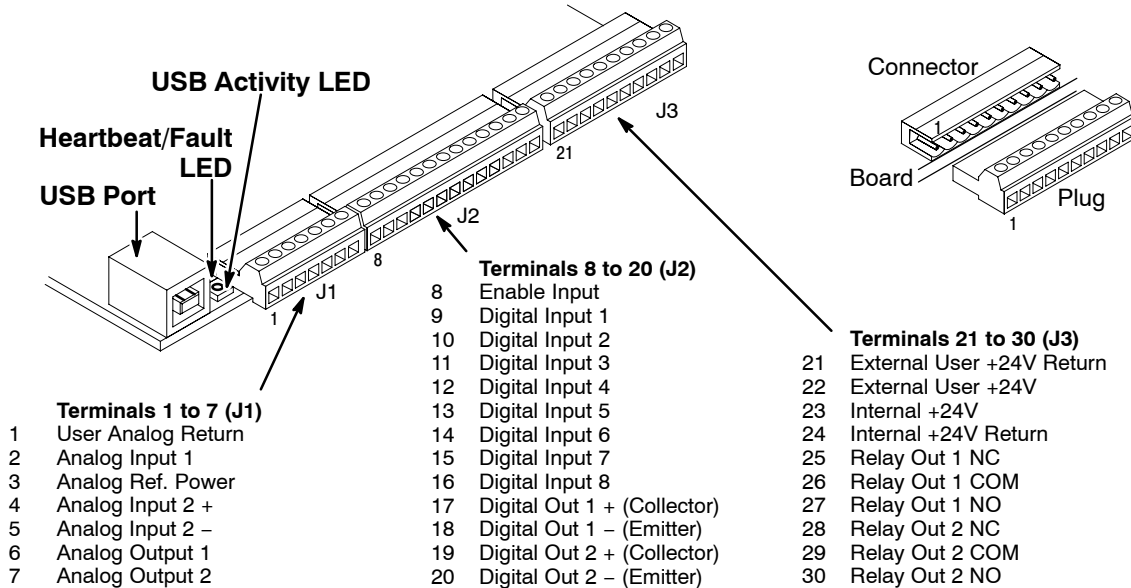

**Table 3-11 J1 Connector Definition**

Connector Terminal	Signal Description
J1-1	0VDC - Common reference for Analog Inputs and outputs.
J1-2	AIN1 - Analog Input 1.
J1-3	AREF - Analog reference power (+10V for Analog Input 1).
J1-4	AIN2+ - Analog Input 2+.
J1-5	AIN2- - Analog Input 2-.
J1-6	AOUT1 - Analog output 1.
J1-7	AOUT2 - Analog output 2.

**Table 3-12 J2 Connector Definition**

Connector Terminal	Signal Description
J2-8	Enable Input
J2-9	DIN1 - Digital input 1.
J2-10	DIN2 - Digital input 2.
J2-11	DIN3 - Digital input 3.
J2-12	DIN4 - Digital input 4.
J2-13	DIN5 - Digital input 5.
J2-14	DIN6 - Digital input 6.
J2-15	DIN7 - Digital input 7.
J2-16	DIN8 - Digital input 8.
J2-17	Digital Output #1 + (Collector)
J2-18	Digital Output #1 - (Emitter)
J2-19	Digital Output #2 + (Collector)
J2-20	Digital Output #2 - (Emitter)



**Table 3-13 J3 Connector Definition**

Connector Terminal	Signal Description
J3-21	External User +24V Return
J3-22	External User +24V
J3-23	Internal +24VDC
J3-24	Internal +24VDC Return
J3-25	Relay Output #1 N.C.
J3-26	Relay Output #1 COMMON
J3-27	Relay Output #1 N.O.
J3-28	Relay Output #2 N.C.
J3-29	Relay Output #2 COMMON
J3-30	Relay Output #2 N.O.

**Analog Inputs**

Two analog inputs are available: Analog Input 1 (J1-1 and J1-2) and Analog Input 2 (J1-4 and J1-5) as shown in Figure 3-14. Either analog input may be selected in the Level 1 Input block, Command Source parameter.

**Figure 3-14 Analog Inputs**

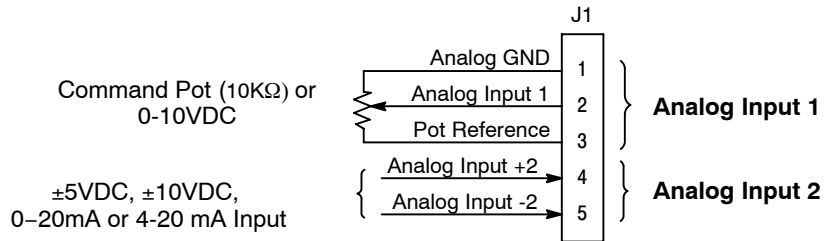

See recommended terminal tightening torques in Section 7.

**Analog Input 1 (Single Ended)** When using a potentiometer as the speed command, process feedback or setpoint source, the potentiometer should be connected at Analog Input 1. When using Analog Input 1, the respective parameter must be set to "Analog Input 1".

Note: A potentiometer value of 5kΩ to 10kΩ, 0.5 watt may be used.

**Parameter Selection**

The single ended Analog Input 1 can be used in one of three ways:

1. Speed or Torque command (Level 1 Input block, Command Source=Analog Input 1).
2. Process Feedback (Level 2 Process Control block, Process Feedback=Analog Input 1).
3. Setpoint Source (Level 2 Process Control block, Setpoint Source=Analog Input 1).

**Analog Input 2 (Differential)**

Analog Input 2 accepts a differential command ±5VDC, ±10VDC, 0-20 mA or 4-20 mA.

If pin J1-4 is positive with respect to pin 5, the motor will rotate in the forward direction.

If pin J1-4 is negative with respect to pin 5, the motor will rotate in the reverse direction.

Analog Input 2 can be connected for single ended operation by connecting either of the differential terminals to common, provided the common mode voltage range is not exceeded.

Analog Input 2 can be set for voltage or current mode operation. With JP1 as shown in Figure 3-15, Voltage mode is selected. If JP1 is connected to pins 2 and 3, current mode is selected.

The Level 1 Input Setup Parameter P#1408 can be set to the full scale voltage or current range desired.

Note: The common mode voltage can be measured with a voltmeter. Apply the maximum command voltage to Analog Input 2 (J1-4, 5). Measure the AC and DC voltage across J1-1 to J1-4. Add the AC and DC values. Measure the AC and DC voltage from J1-1 to J1-5. Add these AC and DC values.

If either of these measurement totals exceeds a total of ±15 volts, then the common mode voltage range has been exceeded. To correct this condition, isolate the command signal with a signal isolator.

**Figure 3-15 Jumper Locations**

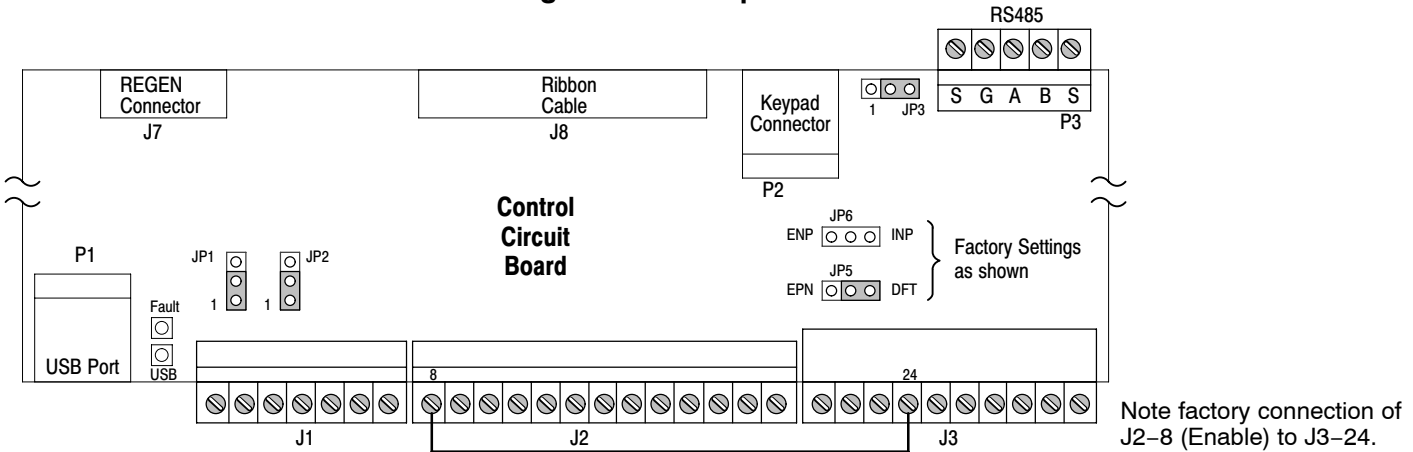

**Analog Outputs**

Two programmable analog outputs are provided on J1-6 and J1-7. These outputs are scaled and can be used to provide status of various control conditions. The return for these outputs is J1-1 analog return. Each output function is programmed in the Level 1 Output block, Analog Out1 Signal or Analog Out2 Signal parameter values. Analog Output 1 can be set for voltage or current mode operation. With JP2 as shown in Figure 3-15, Voltage mode is selected. If JP2 is connected to pins 2 and 3, current mode is selected. The Level 1 Output Setup Parameter P#1510 can be set to the full scale voltage or current range desired.

**Opto Isolated Inputs**

Logic input connections are made at terminal strip J2 pins 8 to 16. J2 inputs can be wired as active High or active Low as shown in Figure 3-16. Internal or external power source is selected by jumpers JP5 and JP6 shown in Figure 3-15.

**Figure 3-16 Active HIGH (Sourcing)/LOW (Sinking) Relationship**

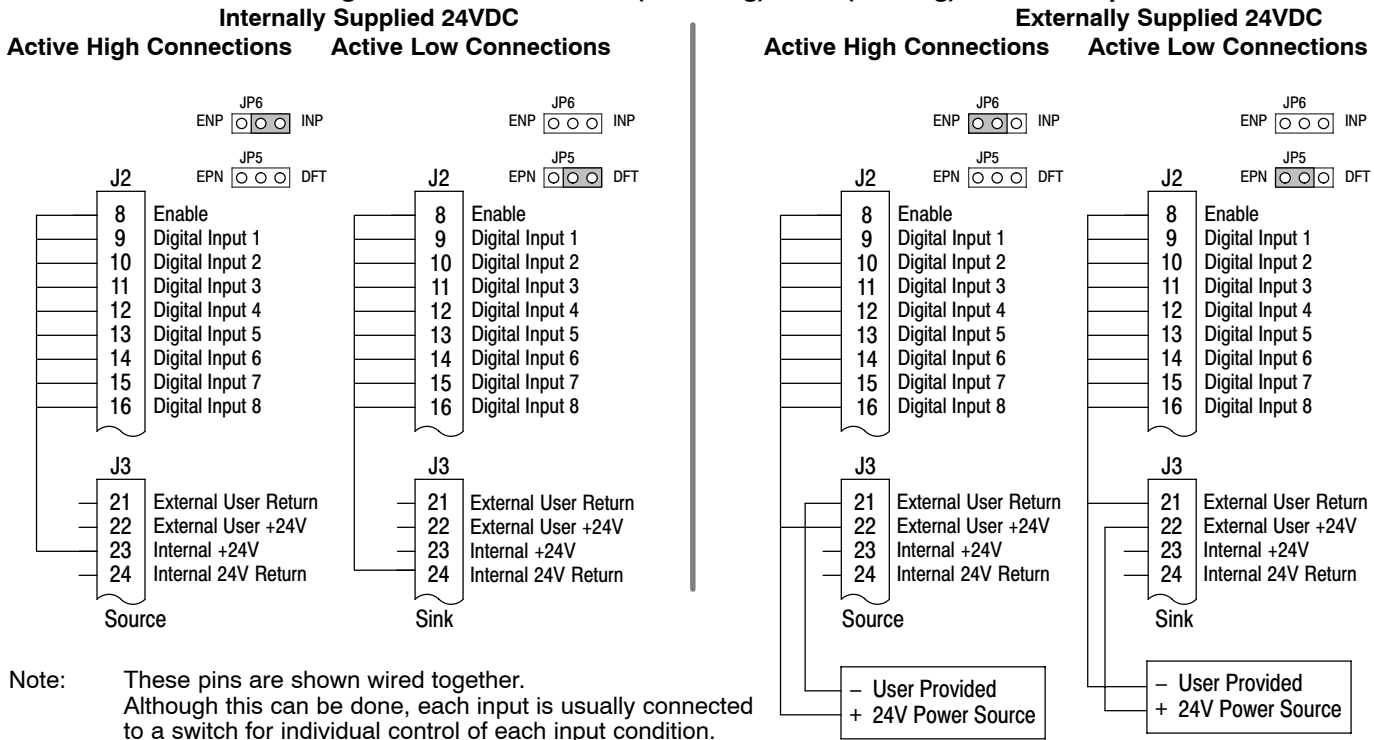

Note: These pins are shown wired together. Although this can be done, each input is usually connected to a switch for individual control of each input condition.

Note: Factory connection of J2-8 (Enable) is made to J3-24 for Internal, Active Low connection. For other configurations, the wire at J3-24 must be moved to J3-23, J3-21 or J3-22 as needed.

**Operating Modes** The operating modes define the basic motor control setup and the operation of the input and output terminals. After the circuit connections are completed, the operating mode is selected by programming the Operating Mode parameter in the Level 1 Input Programming Block.

Operating modes include:

- Keypad
- Standard Run, 2Wire
- Standard Run, 3Wire
- 15 Speed
- Fan Pump 2Wire
- Fan Pump 3Wire
- Process Mode
- 3 SPD ANA 2Wire
- 3 SPD ANA 3Wire
- Electronic Pot 2Wire
- Electronic Pot 3Wire
- Network
- Profile Run
- Mint
- Bipolar

Each mode requires connections to the J1, J2 and J3 terminal strips. The terminal strips are shown in Figure 3-13. The connection of each input or output signal is described in the following pages.

**Keypad**

The Keypad mode allows the control to be operated from the keypad. In this mode only Enable is required. However, the Stop and External Trip inputs may optionally be used. All other Digital Inputs remain inactive. The Analog Outputs and Digital Outputs remain active at all times.

**Figure 3-17 Keypad Connection Diagram**

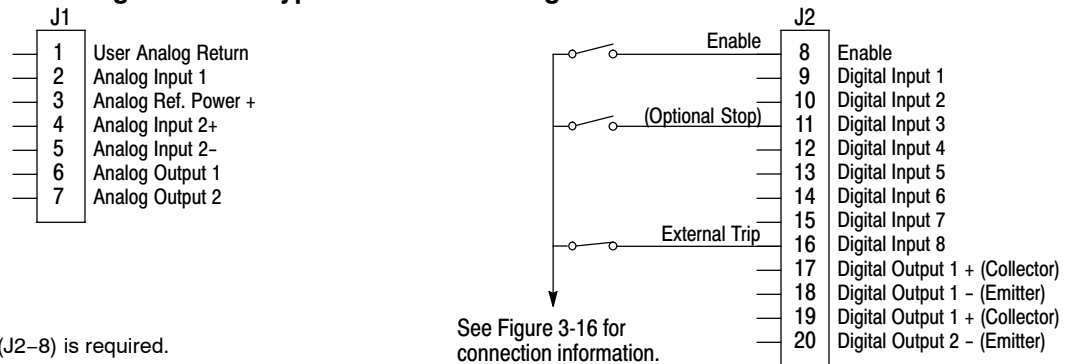

For keypad operation, only Enable (J2-8) is required.

- J2-8 CLOSED allows normal control operation. OPEN disables the control and motor coasts to a stop.
- J2-11 Optional STOP input (not required). OPEN motor coasts or brakes to a stop if Level 1 Keypad Setup block, Local Hot Start parameter is set to "ON". Motor will restart when switch closes after open. CLOSED allows normal control operation.
- J2-16 Optional External Trip input (not required). If used, you must set Level 2 Drive Protection block, External Trip to "ON". CLOSED allows normal operation. OPEN causes an External Trip to be received by the control (when programmed to "ON").

## Standard Run 2Wire

In Standard Run 2Wire mode, the control is operated by the digital inputs and the analog command input. Also, Preset Speed 1 can be selected. The opto inputs can be switches as shown in Figure 3-18 or logic signals from another device.

**Figure 3-18 Standard Run 2Wire Connection Diagram**

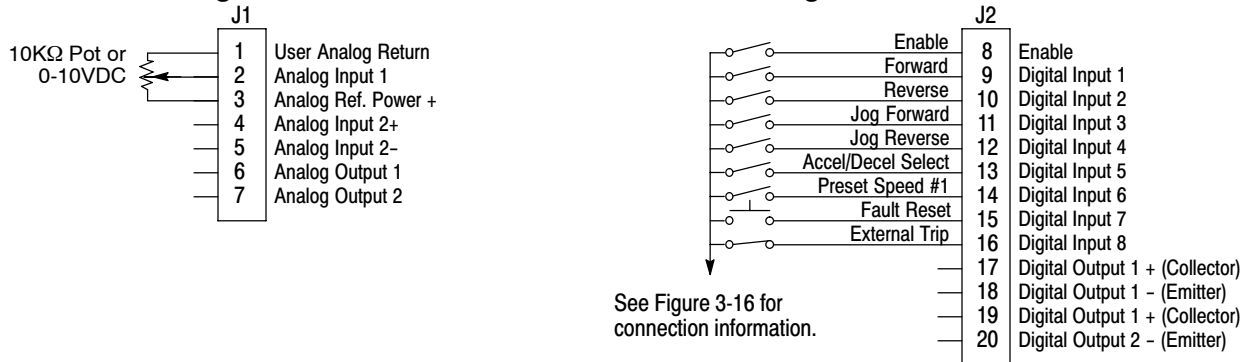

- J2-8      CLOSED allows normal operation.  
OPEN disables the control and motor coasts to a stop.
- J2-9      CLOSED starts motor operation in the Forward direction.  
OPEN motor decels to stop.
- J2-10     CLOSED starts motor operation in the Reverse direction.  
OPEN motor decels to stop.
- J2-11     CLOSED starts motor JOG operation in the Forward direction.  
OPEN motor decels to stop.
- J2-12     CLOSED starts motor JOG operation in the Reverse direction.  
OPEN motor decels to stop.
- J2-13     CLOSED selects ACC / DEC / S-ACC / S-DEC group 2.  
OPEN selects ACC / DEC / S-ACC / S-DEC group 1.
- J2-14     CLOSED selects Preset Speed #1, (J2-11 or 12, will override this Preset Speed).  
OPEN allows speed command from Analog Input 1 or 2.
- J2-15     CLOSED to reset fault.  
OPEN to run.
- J2-16     Optional External Trip input (not required). If used, you must set Level 2 Drive Protection block, External Trip to "ON".  
CLOSED allows normal operation.  
OPEN causes an External Trip to be received by the control (when programmed to "ON").

## Standard Run 3Wire

In Standard Run 3Wire mode, the control is operated by the digital inputs and the analog command input. Also, Preset Speed 1 can be selected. The opto inputs can be switches as shown in Figure 3-19 or logic signals from another device.

**Figure 3-19 Standard Run 3Wire Connection Diagram**

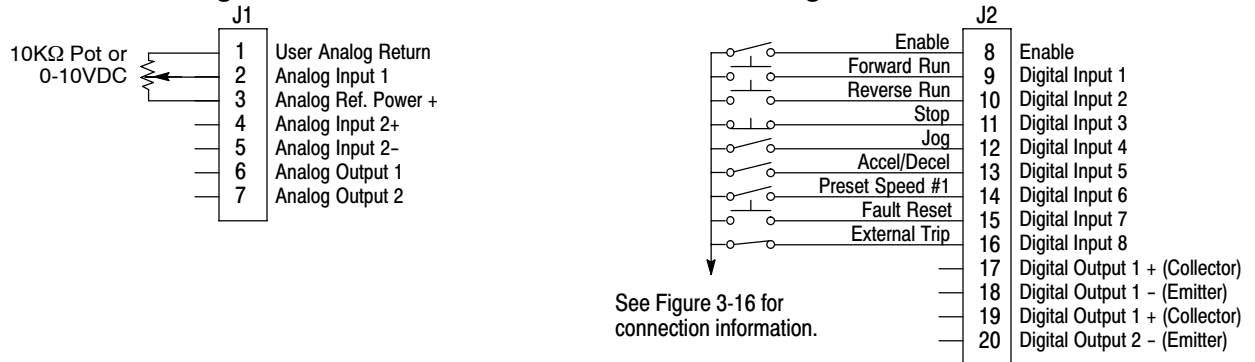

- J2-8      CLOSED allows normal operation.  
OPEN disables the control and motor coasts to a stop.
- J2-9      MOMENTARY CLOSED starts motor operation in the Forward direction.  
In JOG mode (J2-12 CLOSED), continuous closed jogs motor in the Forward direction.
- J2-10     MOMENTARY CLOSED starts motor operation in the Reverse direction.  
In JOG mode (J2-12 CLOSED), continuous closed jogs motor in the Reverse direction.
- J2-11     MOMENTARY OPEN motor decels to stop (depending on Decel time).
- J2-12     CLOSED places control in JOG mode, Forward and Reverse run are used to jog the motor.
- J2-13     CLOSED selects ACC / DEC / S-ACC / S-DEC group 2.  
OPEN selects ACC / DEC / S-ACC / S-DEC group 1.
- J2-14     CLOSED selects Preset Speed #1, (J2-12, will override this Preset Speed).  
OPEN allows speed command from Analog Input 1 or 2.
- J2-15     CLOSED to reset fault.  
OPEN to run.
- J2-16     Optional External Trip input (not required). If used, you must set Level 2 Drive Protection block, External Trip to "ON".  
CLOSED allows normal operation.  
OPEN causes an External Trip to be received by the control (when programmed to "ON").

## 15 Speed

Operation in 8 Speed 2-Wire mode is controlled by the opto isolated inputs at J2. Preset Speeds are set in software. J2-11 through J2-14 inputs allow selection of 15 Preset Speeds. The opto inputs can be switches as shown in Figure 3-20 or logic signals from another device.

**Figure 3-20 15 Speed 2Wire Connection Diagram**

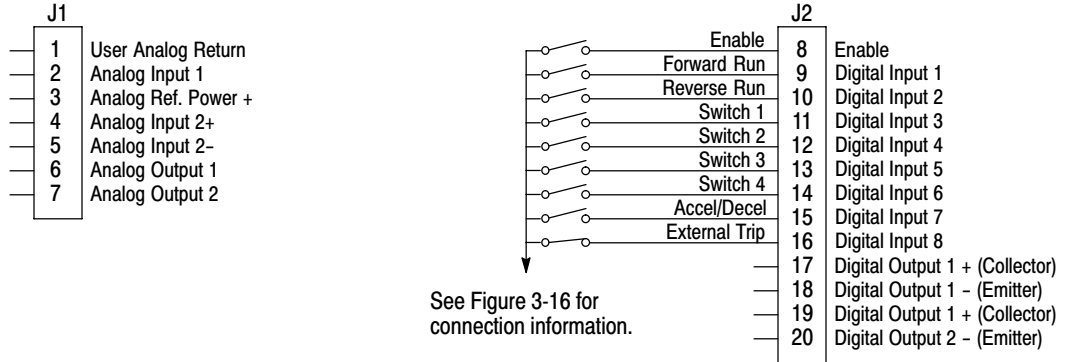

- J2-8      CLOSED allows normal operation.  
OPEN disables the control and motor coasts to a stop.
- J2-9      CLOSED operates the motor in the Forward direction (with J2-10 open).  
OPEN motor decels to stop (depending on Decel time).
- J2-10     CLOSED operates motor in the Reverse direction (with J2-9 open).  
OPEN motor decels to stop (depending on Decel time).
- J2-11-14 Selects programmed Preset Speeds as defined in Table 3-14.
- J2-15     CLOSED selects ACC / DEC / S-ACC / S-DEC group 2.  
OPEN selects ACC / DEC / S-ACC / S-DEC group 1.
- J2-16     Optional External Trip input (not required). If used, you must set Level 2 Drive Protection block, External Trip to "ON".  
CLOSED allows normal operation.  
OPEN causes an External Trip to be received by the control (when programmed to "ON").

**Table 3-14 Switch Truth Table for 15 Speed, 2Wire Control Mode**

Function	J2-11	J2-12	J2-13	J2-14
Preset 1	Open	Open	Open	Open
Preset 2	Closed	Open	Open	Open
Preset 3	Open	Closed	Open	Open
Preset 4	Closed	Closed	Open	Open
Preset 5	Open	Open	Closed	Open
Preset 6	Closed	Open	Closed	Open
Preset 7	Open	Closed	Closed	Open
Preset 8	Closed	Closed	Closed	Open
Preset 9	Open	Open	Open	Closed
Preset 10	Closed	Open	Open	Closed
Preset 11	Open	Closed	Open	Closed
Preset 12	Closed	Closed	Open	Closed
Preset 13	Open	Open	Closed	Closed
Preset 14	Closed	Open	Closed	Closed
Preset 15	Open	Closed	Closed	Closed
Fault Reset	Closed	Closed	Closed	Closed

## Fan Pump 2Wire

Operation in the Fan Pump 2-Wire mode is controlled by the opto isolated inputs at J2-8 through J2-16. The opto inputs can be switches as shown in Figure 3-21 or logic signals from another device.

**Figure 3-21 Fan Pump 2Wire Connection Diagram**

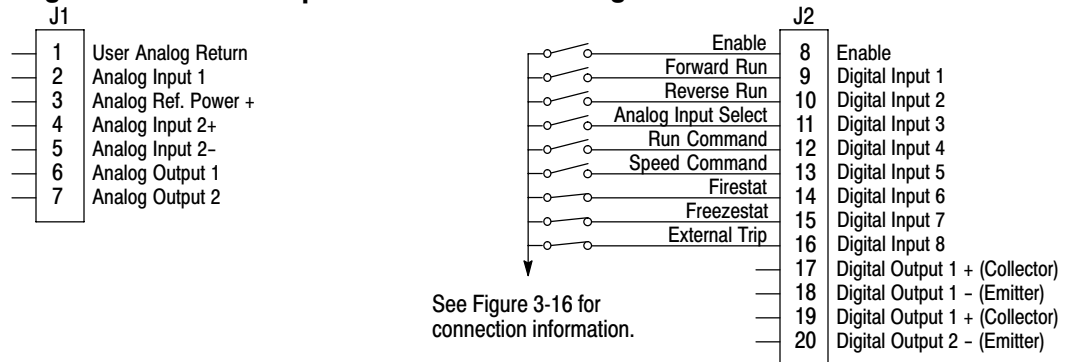

- J2-8 CLOSED allows normal control operation.  
OPEN disables the control and the motor coasts to a stop.
- J2-9 CLOSED operates the motor in the Forward direction (with J2-10 open).  
OPEN motor decels to stop (depending on Decel Time).  
Note: J2-9 and J2-10 are both closed = Fault Reset.
- J2-10 CLOSED operates the motor in the Reverse direction (with J2-9 open).  
OPEN motor decels to stop (depending on Decel Time).  
Note: J2-9 and J2-10 are both closed = Fault Reset.
- J2-11 CLOSED selects Analog Input 1 (if J2-13, J2-14 and J2-15 are closed).  
OPEN selects Command Source (Level 1, Input, Command Source, if J2-13, J2-14 and J2-15 are closed).
- J2-12 CLOSED selects STOP/START and Reset commands from terminal strip.  
OPEN selects STOP/START and Reset commands from Keypad.
- J2-13 CLOSED allows other selections, see Speed Select Table 3-15.  
OPEN selects speed commanded from Keypad (if J2-14 and J2-15 are closed).
- Note: When changing from Terminal Strip to Keypad (J2-12 or J2-13) the motor speed and direction will remain the same after the change.
- J2-14 Firestat. Selects Level 1, Preset Speeds, Preset Speed #1.
- J2-15 Freezestat. Level 1, Preset Speeds, Preset Speed #2 (if J2-14 is closed).
- J2-16 Optional External Trip input (not required). If used, you must set Level 2 Drive Protection block, External Trip to "ON".  
CLOSED allows normal operation.  
OPEN causes an External Trip to be received by the control (when programmed to "ON").

**Table 3-15 Speed Select Table – Fan Pump, 2Wire**

J2-11	J2-13	J2-14	J2-15	Command
	Open	Closed	Closed	Keypad Speed Command
		Open		Level 1, Preset Speeds, Preset Speed #1
		Closed	Open	Level 1, Preset Speeds, Preset Speed #2
Open	Closed	Closed	Closed	Level 1, Input Setup, Command Source (parameter 1402)
Closed	Closed	Closed	Closed	Analog Input 1

## Fan Pump 3Wire

Operation in the Fan Pump 3-Wire mode is controlled by the opto isolated inputs at J2-8 through J2-16. The opto inputs can be switches as shown in Figure 3-22 or logic signals from another device.

**Figure 3-22 Fan Pump 3Wire Connection Diagram**

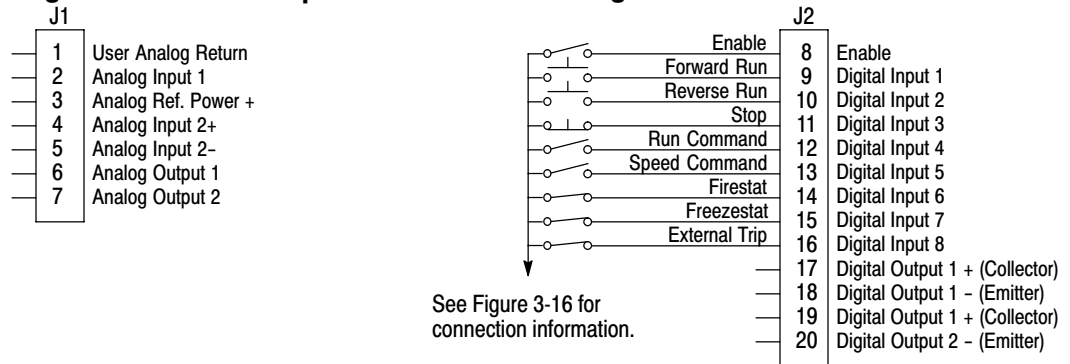

- J2-8 CLOSED allows normal control operation.  
OPEN disables the control and the motor coasts to a stop.
- J2-9 MOMENTARY CLOSED starts motor operation in the Forward direction.  
Note: Closing both J2-9 and J2-10 at the same time will reset a fault.
- J2-10 MOMENTARY CLOSED starts motor operation in the Reverse direction.  
Note: Closing both J2-9 and J2-10 at the same time will reset a fault.
- J2-11 MOMENTARY OPEN motor decels to stop (depending on Decel Time).
- J2-12 CLOSED selects STOP/START and Reset commands from terminal strip.  
OPEN selects STOP/START and Reset commands from Keypad.
- J2-13 CLOSED allows other selections, see Speed Select Table 3-16.  
OPEN selects speed commanded from Keypad (if J2-14 and J2-15 are closed).
- Note: When changing from Terminal Strip to Keypad (J2-12 or J2-13) the motor speed and direction will remain the same after the change.
- J2-14 Firestat. Selects Level 1, Preset Speeds, Preset Speed #1.
- J2-15 Freezestat. Selects Level 1, Preset Speeds, Preset Speed #2 (if J2-14 is closed).
- J2-16 Optional External Trip input (not required). If used, you must set Level 2 Drive Protection block, External Trip to "ON".  
CLOSED allows normal operation.  
OPEN causes an External Trip to be received by the control (when programmed to "ON").

**Table 3-16 Speed Select Table – Fan Pump, 3Wire**

J2-13	J2-14	J2-15	Command
	Open		Level 1, Preset Speeds, Preset Speed #1
	Closed	Open	Level 1, Preset Speeds, Preset Speed #2
Open	Closed	Closed	Keypad Speed Command
Closed	Closed	Closed	Level 1, Input Setup, Command Source (parameter 1402)



**Process Control** The process control mode provides an auxiliary closed loop general purpose PID set point control. The process control loop may be configured in various ways and detailed descriptions of the process mode are given in MN707 "Introduction to Process Control". The opto inputs can be switches as shown in Figure 3-23 or logic signals from another device.

**Figure 3-23 Process Control Connection Diagram**

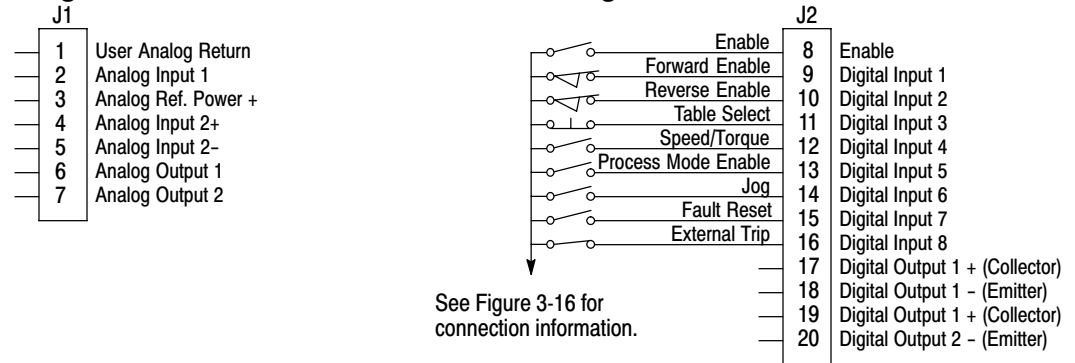

- J2-8      CLOSED allows normal control operation.  
OPEN disables the control and the motor coasts to a stop.
- J2-9      CLOSED to enable operation in the Forward direction.  
OPEN TO DISABLE Forward operation (drive will decel to a stop if a Forward command is still present).  
Reverse operation is still possible if J2-10 is closed.
- J2-10     CLOSED to enable operation in the Reverse direction.  
OPEN to disable Reverse operation (drive will decel to a stop if a Reverse command is still present).  
Forward operation is still possible if J2-9 is closed.  
  - Note: If J2-9 and J2-10 are both opened, the drive will decel to a stop.
- J2-11     CLOSED = TABLE 2, OPEN = TABLE 1. Refer to Table 3-17.
- J2-12     CLOSED, the control is in torque command mode.  
OPEN, the control is in speed (velocity) command mode.
- Note: If a stop command is issued while in the torque (current) mode, the control will stop but will not maintain position (zero current). This is different than zero speed operation for the velocity mode.
- J2-13     CLOSED to enable the Process Mode.
- J2-14     CLOSED places control in JOG mode. The control will only JOG in the forward direction.
- J2-15     CLOSED to reset a fault.  
OPEN to run.
- J2-16     Optional External Trip input (not required). If used, you must set Level 2 Drive Protection block, External Trip to "ON".  
CLOSED allows normal operation.  
OPEN causes an External Trip to be received by the control (when programmed to "ON").

**Table 3-17 Table Select – Process Mode**

J2-11	Command
Open	Selects Parameter Table 1
Closed	Selects Parameter Table 2

Note: See multiple parameter sets in this section.

### 3 Speed Analog 2Wire

Allows selection of 3 Preset Speeds with 2Wire inputs. The values of the Preset Speeds are set in the Level 1 Preset Speeds block, Preset Speed #1, Preset Speed #2 and Preset Speed #3. The opto inputs can be switches as shown in Figure 3-24 or logic signals from another device.

**Figure 3-24 3 Speed Analog 2Wire Connection Diagram**

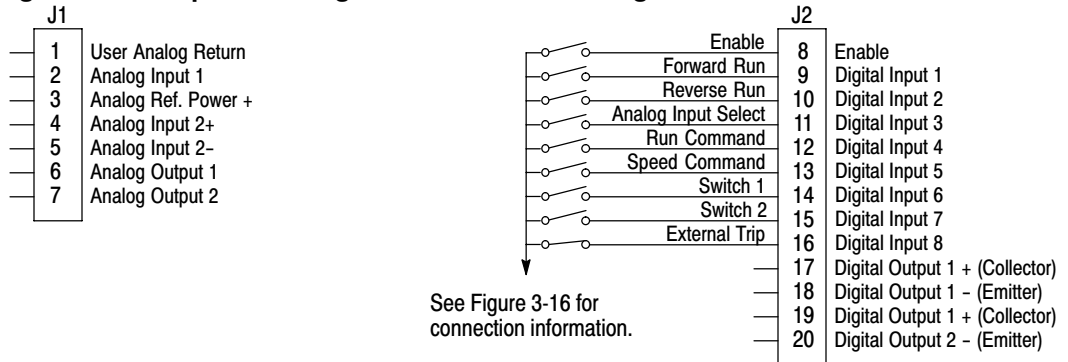

- J2-8      CLOSED allows normal control operation.  
OPEN disables the control and the motor coasts to a stop.
- J2-9      CLOSED operates the motor in the Forward direction (with J2-10 open).  
OPEN motor decels to stop (depending on Decel time).
- J2-10     CLOSED operates the motor in the Reverse direction (with J2-9 open).  
OPEN motor decels to stop (depending on Decel time).  
  - Note: Closing both J2-9 and J2-10 at the same time will reset a fault.
- J2-11     CLOSED selects Analog Input 1.  
OPEN selects Level 1 Input block, Command Source parameter.  
  - Note: If Command Source (Level 1 Input block) is set to Analog Input 1, then Analog Input 1 is always selected regardless of this switch position.
- J2-12     CLOSED selects STOP/START and Reset commands from terminal strip.  
OPEN selects STOP/START and Reset commands from Keypad.
- J2-13     CLOSED selects Level 1 Input block, Command Source parameter.  
OPEN selects speed commanded from Keypad.  
  - Note: When changing from Terminal Strip to Keypad (J2-12 or J2-13) the motor speed and direction will remain the same after the change.
- J2-14     Selects Preset Speeds as defined in the Speed Select Table (Table 3-18).
- J2-15     Selects Preset Speeds as defined in the Speed Select Table (Table 3-18).
- J2-16     Optional External Trip input (not required). If used, you must set Level 2 Drive Protection block, External Trip to "ON".  
CLOSED allows normal operation.  
OPEN causes an External Trip to be received by the control (when programmed to "ON").

**Table 3-18 Speed Select Table**

J2-14	J2-15	Command
OPEN	OPEN	Level 1, Input Setup, Command Source (parameter 1402)
CLOSED	OPEN	Preset #1
OPEN	CLOSED	Preset #2
CLOSED	CLOSED	Preset #3

### 3 Speed Analog 3Wire

Allows selection of 3 Preset Speeds with 3Wire inputs. The values of the Preset Speeds are set in the Level 1 Preset Speeds block, Preset Speed #1, Preset Speed #2 and Preset Speed #3. The opto inputs can be switches as shown in Figure 3-25 or logic signals from another device.

**Figure 3-25 3 Speed Analog 3Wire Connection Diagram**

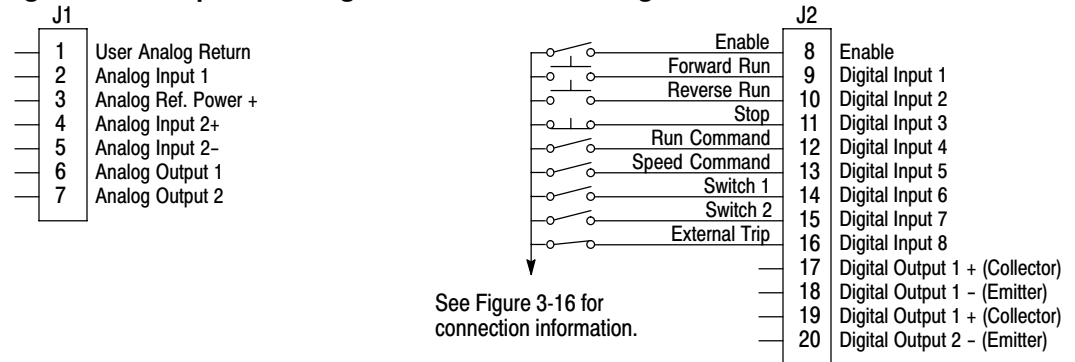

- J2-8 CLOSED allows normal control operation.  
OPEN disables the control and the motor coasts to a stop.
- J2-9 MOMENTARY CLOSED starts motor operation in the Forward direction.
- J2-10 MOMENTARY CLOSED starts motor operation in the Reverse direction.  
Note: Closing both J2-9 and J2-10 at the same time will reset a fault.
- J2-11 MOMENTARY OPEN motor decels to stop (depending on Decel time).
- J2-12 CLOSED selects STOP/START and Reset commands from terminal strip.  
OPEN selects STOP/START and Reset commands from Keypad.
- J2-13 CLOSED selects Level 1 Input block, Command Source parameter.  
OPEN selects speed commanded from Keypad.  
Note: When changing from Terminal Strip to Keypad (J2-12 or J2-13) the motor speed and direction will remain the same after the change.
- J2-14 Selects Preset Speeds as defined in the Speed Select Table (Table 3-19).
- J2-15 Selects Preset Speeds as defined in the Speed Select Table (Table 3-19).
- J2-16 Optional External Trip input (not required). If used, you must set Level 2 Drive Protection block, External Trip to "ON".  
CLOSED allows normal operation.  
OPEN causes an External Trip to be received by the control (when programmed to "ON").

**Table 3-19 Speed Select Table**

J2-14	J2-15	Command
OPEN	OPEN	Level 1, Input Setup, Command Source (parameter 1402)
CLOSED	OPEN	Preset #1
OPEN	CLOSED	Preset #2
CLOSED	CLOSED	Preset #3

## E-POT 2Wire

Provides speed Increase and Decrease inputs to allow E-POT (Electronic Potentiometer) operation with 2Wire inputs. The values of the Preset Speeds are set in the Level 1 Preset Speeds block, Preset Speed #1 or Preset Speed #2. The opto inputs can be switches as shown in Figure 3-26 or logic signals from another device.

**Figure 3-26 E-POT 2Wire Connection Diagram**

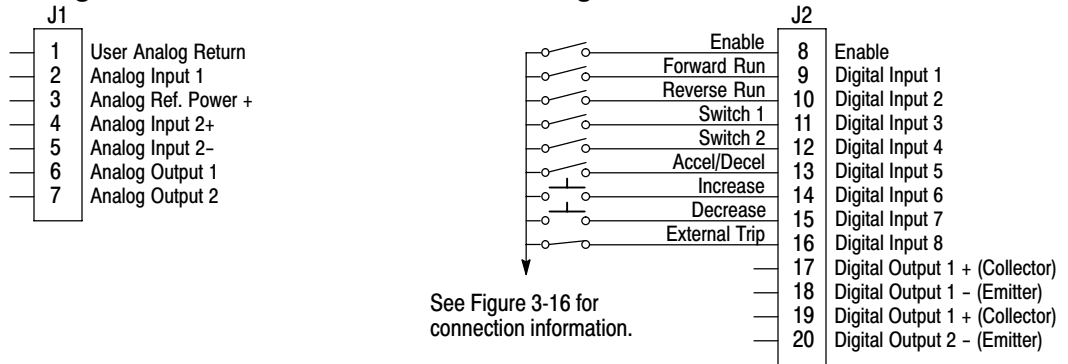

- J2-8 CLOSED allows normal control operation.  
OPEN disables the control and the motor coasts to a stop.
- J2-9 CLOSED starts motor operation in the Forward direction.  
OPEN motor decels to stop (depending on Decel time).
- J2-10 CLOSED starts motor operation in the Reverse direction.  
OPEN motor decels to stop (depending on Decel time).

Note: Closing both J2-9 and J2-10 at the same time will reset a fault.

- J2-11 Selects Preset Speeds as defined in the Speed Select Table (Table 3-20).
- J2-12 Selects Preset Speeds as defined in the Speed Select Table (Table 3-20).
- J2-13 CLOSED selects ACC / DEC / S-ACC / S-DEC group 2.  
OPEN selects ACC / DEC / S-ACC / S-DEC group 1.
- J2-14 MOMENTARY CLOSED increases motor speed while contact is closed.
- J2-15 MOMENTARY CLOSED decreases motor speed while contact is closed.
- J2-16 Optional External Trip input (not required). If used, you must set Level 2 Drive Protection block, External Trip to "ON".  
CLOSED allows normal operation.  
OPEN causes an External Trip to be received by the control (when programmed to "ON").

**Table 3-20 Speed Select Table**

J2-11	J2-12	Function
OPEN	OPEN	Electronic Pot
CLOSED	OPEN	Level 1, Input Setup, Command Source (parameter 1402)
OPEN	CLOSED	Preset #1
CLOSED	CLOSED	Preset #2

## E-POT 3Wire

Provides speed Increase and Decrease inputs to allow E-POT operation with 3Wire inputs. The opto inputs can be switches as shown in Figure 3-27 or logic signals from another device.

**Figure 3-27 E-POT 3Wire Connection Diagram**

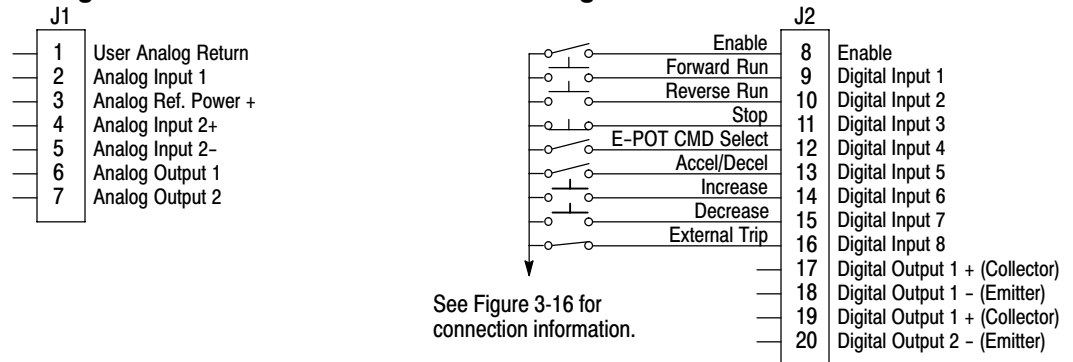

- J2-8      CLOSED allows normal control operation.  
OPEN disables the control and the motor coasts to a stop.
- J2-9      MOMENTARY CLOSED starts motor operation in the Forward direction.
- J2-10     MOMENTARY CLOSED starts motor operation in the Reverse direction.  
  - Note: Closing both J2-9 and J2-10 at the same time will reset a fault.
- J2-11     Momentary OPEN motor decels to stop (depending on Decel time).
- J2-12     CLOSED selects Level 1 Command Source parameter value.  
OPEN selects E-POT.
- J2-13     CLOSED selects ACC / DEC / S-ACC / S-DEC group 2.  
OPEN selects ACC / DEC / S-ACC / S-DEC group 1.
- J2-14     MOMENTARY CLOSED increases motor speed while contact is closed.
- J2-15     MOMENTARY CLOSED decreases motor speed while contact is closed.
- J2-16     Optional External Trip input (not required). If used, you must set Level 2 Drive Protection block, External Trip to "ON".  
CLOSED allows normal operation.  
OPEN causes an External Trip to be received by the control (when programmed to "ON").

**Network**

The digital inputs can be switches as shown in Figure 3-28 or logic signals from another device.

**Figure 3-28 Network Connection Diagram**

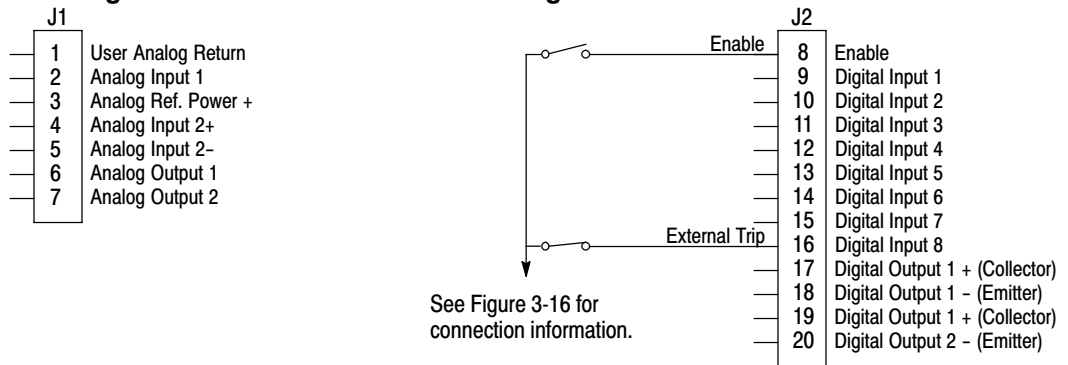

- J2-8 CLOSED allows normal control operation.  
OPEN disables the control and the motor coasts to a stop.
- J2-9 Not used (unless configured using Mint for setup)
- J2-10 Not used (unless configured using Mint for setup)
- J2-11 Not used (unless configured using Mint for setup)
- J2-12 Not used (unless configured using Mint for setup)
- J2-13 Not used (unless configured using Mint for setup)
- J2-14 Not used (unless configured using Mint for setup)
- J2-15 Not used (unless configured using Mint for setup)
- J2-16 Optional External Trip input (not required). If used, you must set Level 2 Drive Protection block, External Trip to "ON".  
CLOSED allows normal operation.  
OPEN causes an External Trip to be received by the control (when programmed to "ON").

**Profile Run** Provides seven run profiles to setup a cyclic operation or test cycle. The opto inputs can be switches as shown in Figure 3-29 or logic signals from another device. Speed settings for Speed curve 1 – 7 is Preset Speed 1 to Preset Speed 7.

**Figure 3-29 Profile Run Connection Diagram**

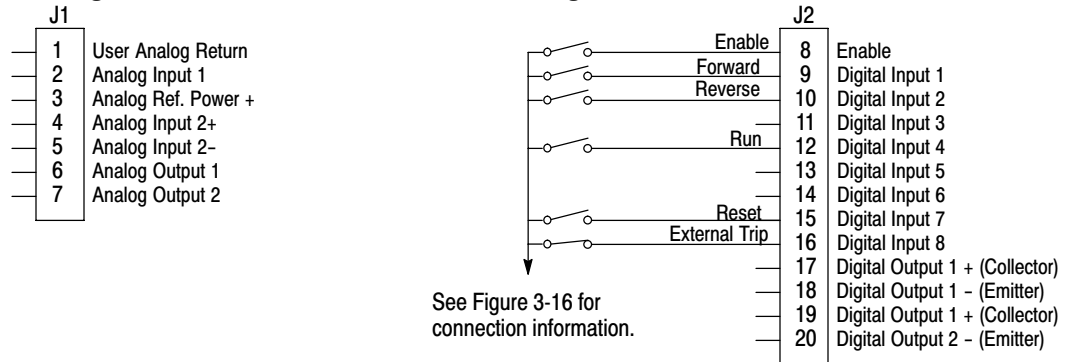

- J2-8      CLOSED allows normal operation.  
OPEN disables the control and motor coasts to a stop.
- J2-9      CLOSED to maintain operation in the Forward direction.  
OPEN TO DISABLE Forward operation (drive will decel to a stop if a Forward command is still present).  
Reverse operation is still possible if J2-10 is closed.
- J2-10     CLOSED to maintain operation in the Reverse direction.  
OPEN to disable Reverse operation (drive will decel to a stop if a Reverse command is still present).  
Forward operation is still possible if J2-9 is closed.
- J2-11     Not used.
- J2-12     CLOSED uses Run Command from J2-9 or J2-10.  
OPEN uses Run Command from Keypad.
- J2-13     Not used.
- J2-14     Not used.
- J2-15     CLOSED resets an alarm or fault.  
OPEN normal operation.
- J2-16     Optional External Trip input (not required). If used, you must set Level 2 Drive Protection block, External Trip to "ON".  
CLOSED allows normal operation.  
OPEN causes an External Trip to be received by the control (when programmed to "ON").

**Bipolar**

Provides bipolar speed or torque control. Preset Speeds are set in software. The opto inputs can be switches as shown in Figure 3-30 or logic signals from another device.

**Figure 3-30 Bipolar Connection Diagram**

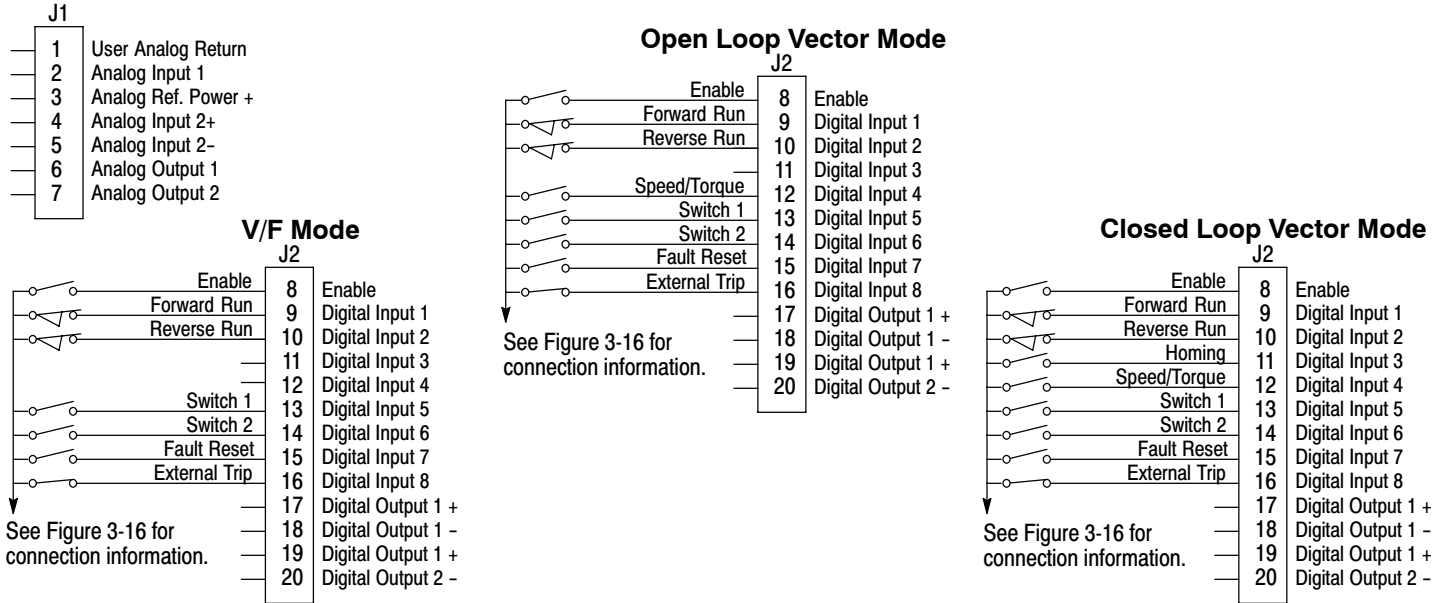

J2-8 CLOSED allows normal control operation. OPEN disables the control and the motor coasts to a stop.

J2-9 CLOSED to enable operation in the Forward direction. OPEN TO DISABLE Forward operation (drive will decel to a stop if a Forward command is still present). Reverse operation is still possible if J2-10 is closed.

J2-10 CLOSED to enable operation in the Reverse direction. OPEN to disable Reverse operation (drive will decel to a stop if a Reverse command is still present). Forward operation is still possible if J2-9 is closed.

Note: If J2-9 and J2-10 are both opened, the drive will decel to a stop.

J2-11 CLOSED causes the motor to rotate in the forward direction until the load reaches a marker or external switch location. OPEN allows normal operation.

J2-12 CLOSED puts the control in torque command mode. OPEN puts the control in speed (velocity) command mode.

Note: If a stop command is issued while in the torque (current) mode, the control will stop but will not maintain position (zero current). This is different than zero speed operation for the velocity mode.

J2-13 & 14 Select from four parameter tables as defined in Table 3-21.

J2-15 Momentary CLOSED to reset fault condition. OPEN allows normal operation.

J2-16 Optional External Trip input (not required). If used, you must set Level 2 Drive Protection block, External Trip to "ON". CLOSED allows normal operation. OPEN causes an External Trip to be received by the control (when programmed to "ON").

**Table 3-21 Bipolar Mode Table Select Truth Table**

J2-13	J2-14	Function
Open	Open	Parameter Table 1 (T1)
Closed	Open	Parameter Table 2 (T2)
Open	Closed	Parameter Table 3 (T3)
Closed	Closed	Parameter Table 4 (T4)

Note: See multiple parameter sets in this section.



---

## Multiple Parameter Sets

The following procedure allows you to program up to four complete sets of parameter values and to use these multiple parameter sets. When programming each parameter set, use the ENTER key to accept and automatically save parameter values.

Note: The control can be programmed in the REMOTE mode with the drive enabled. The control must be disabled to change the operating mode parameter. The operating mode is not stored with the other parameters in a parameter table.

1. If this is a new installation, do this procedure after the Pre-Operation Checklist and Power-Up Procedures at the end of this section.
2. Set the Level 1 INPUT block, Operating Mode parameter value to BIPOLAR in each of the parameter sets.
3. Set switches J2-13 and J2-14 to Parameter Table 1 (both switches open). Be sure switches J2-9 and J2-10 are OPEN, J2-8 is CLOSED.  
Enter all parameter values, and autotune as instructed in Section 3 of this manual.  
This creates and saves the first parameter set which is numbered Table 1.
4. Set switches J2-13 and J2-14 to Parameter Table 2. Be sure switches J2-9 and J2-10 are OPEN, J2-8 is CLOSED. Enter all parameter values, and autotune as instructed in Section 3 of this manual.  
This creates and saves the second parameter set which is numbered Table 2.
5. Set switches J2-13 and J2-14 to Parameter Table 3. Be sure switches J2-9 and J2-10 are OPEN, J2-8 is CLOSED. Enter all parameter values, and autotune as instructed in Section 3 of this manual.  
This creates and saves the third parameter set which is numbered Table 3.
6. Set switches J2-13 and J2-14 to Parameter Table 4. Be sure switches J2-9 and J2-10 are OPEN, J2-8 is CLOSED. Enter all parameter values, and autotune as instructed in Section 3 of this manual.  
This creates and saves the final parameter set which is numbered Table 4.
7. Remember that to change the value of a parameter in one of the parameter tables, you must first select the table using the switches. You cannot change a value in a table until you have first selected that table.

## Digital Outputs

Digital Outputs 1 and 2 are opto isolated. Internal supply or a customer provided, external power source may be used as shown in Figure 3-31. The maximum voltage from Digital Output to common when active is 1.0 VDC (TTL compatible).

If the Digital Outputs are used to directly drive a relay, a flyback diode rated at 1A, 100V (IN4002 or equivalent) minimum should be connected across the relay coil. See Figure 3-32. Each opto output is programmed in the Output programming block.

**Figure 3-31 Digital Output Power Connections**

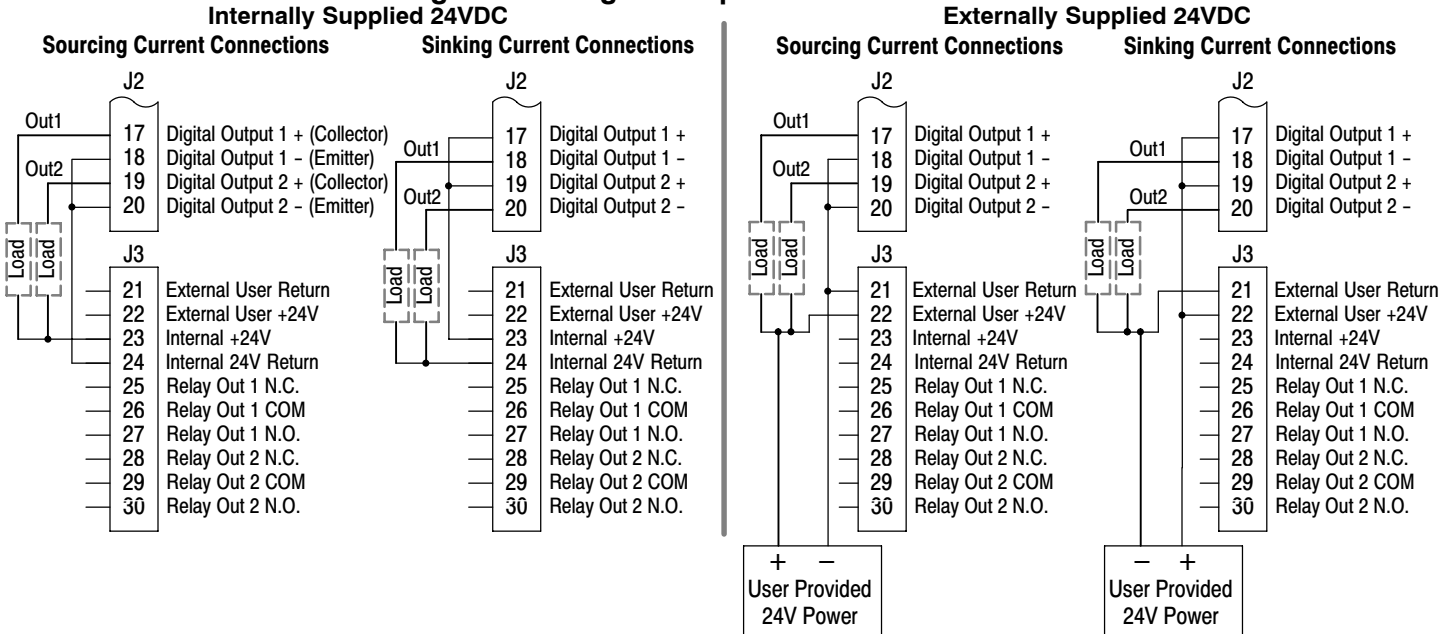

Note: Digital Outputs are rated to 24VDC @ 60mA resistive (non-inductive).  
Relay Outputs are rated to 10–30VDC or 240VAC @ 5A resistive (non-inductive).

## Relay Outputs

Relay Outputs 1 and 2 provide N.O. and N.C. voltage free contacts. The internal relay function is shown in Figure 3-32.

**Figure 3-32 Relay Contacts**

If the load is a DC relay coil, install a flyback diode across the coil to reduce + noise transmission.

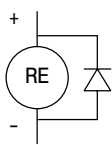

If the load is an AC relay coil, install an RC Snubber across the coil to reduce noise transmission.

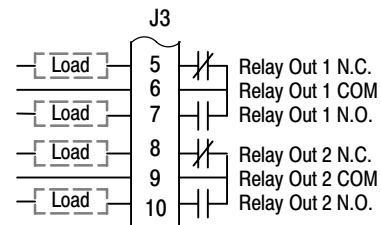
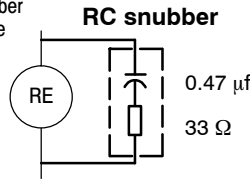

## USB Port

The USB port shown in Figure 3-34 is a full 12Mbps USB 2.0 compliant port for serial communications. The connections are described in Figure 3-33 and Table 3-22.

**Figure 3-33 USB Receptacle Pin Identification**

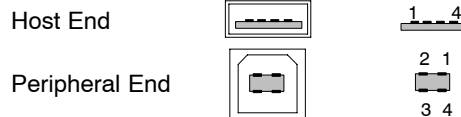

**Table 3-22 USB Port Connections**

Pin	Signal Name	Description
1	V <sub>bus</sub>	USB power from the host for monitoring.
2	D-	Data Return
3	D+	Data In
4	GND	Power Supply Return

**Figure 3-34 Expansion Board Location**

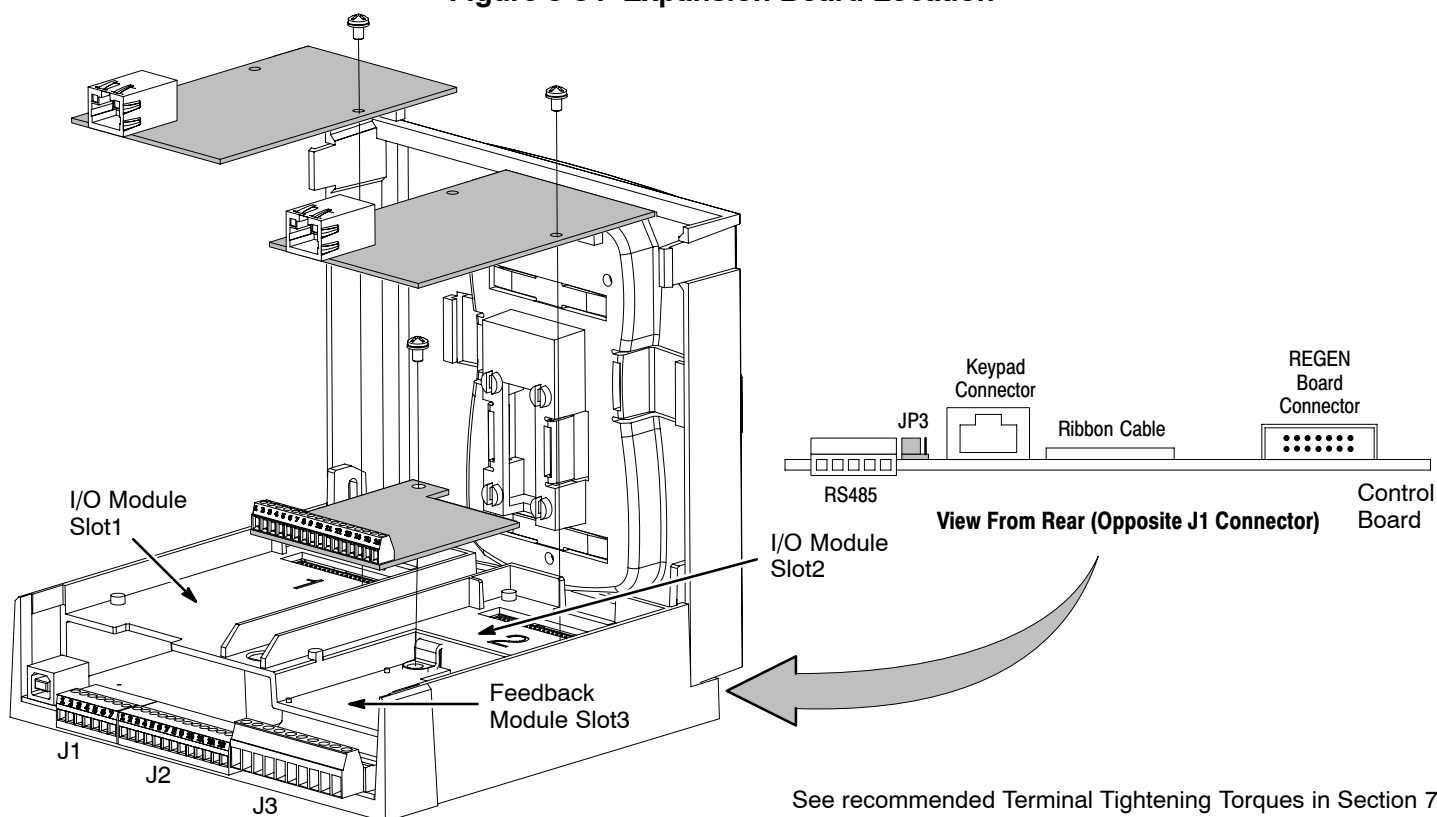

See recommended Terminal Tightening Torques in Section 7.

**Communication Expansion Boards**

The communication and feedback module slots are shown in Figure 3-34. All option boards are designed as plug-in modules.

**RS485 Modbus** The serial communications port on the H2 control board supports RS485 communications, Figure 3-34. The baud rate and node address are selectable from the Keypad. Jumper JP3 (Figure 3-34) on the control board sets termination. As shown (pins 2 and 3 jumpered) no terminator resistor is used. Setting the jumper to pins 1 and 2 selects the 120 ohm terminating resistor for the RES485 cable. The RS485 connections are described in Table 3-23.

**Table 3-23 RS485 Multi-Drop Port Connections**

	Pin	Signal Name	Description
	1	SCR	Screen termination, connected to chassis on the control board.
	2	B	RS485 data line
	3	A	RS485 data line
	4	GND	Common
	5	SCR	Screen termination, connected to chassis on the control board.

## Opto-Isolated Inputs

The equivalent circuit of the nine opto inputs is shown in Figure 3-35. The function of each input depends on the operating mode selected and are described previously in this section. This Figure also shows the connections using the internal opto input Supply.

**Figure 3-35 Opto-Input Connections**

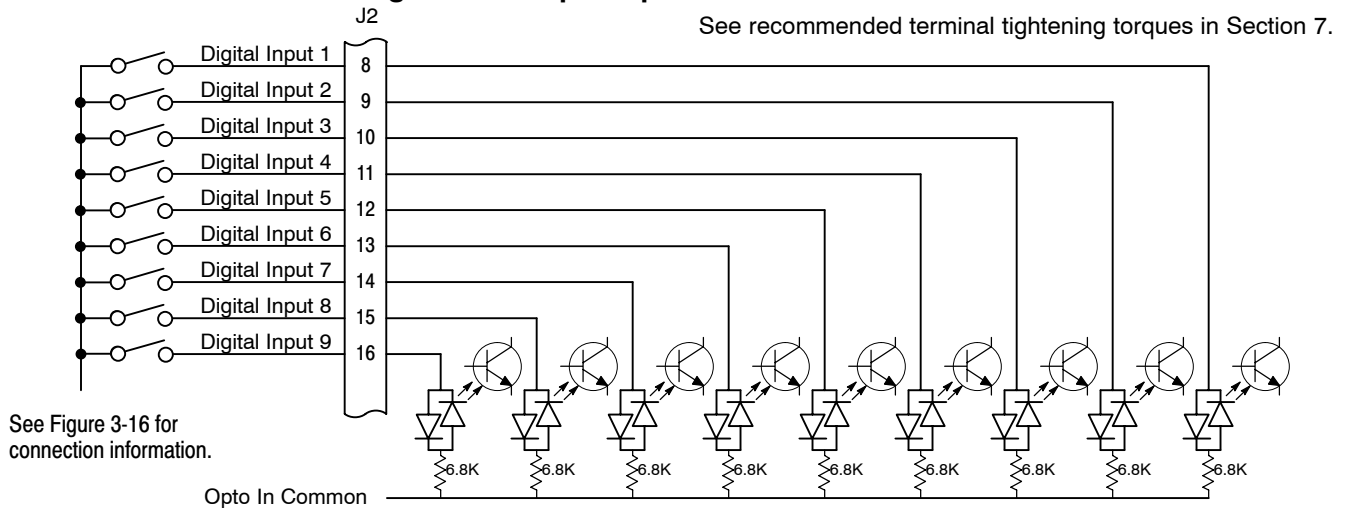

## Opto Isolated Outputs

The outputs are opto isolated and may be configured for sinking or sourcing. However, all must be configured the same. The maximum voltage from opto output to common when active is 1.0 VDC (TTL compatible). The equivalent circuit for the opto isolated outputs is shown in Figure 3-36.

**Figure 3-36 Opto-Output Equivalent Circuit**

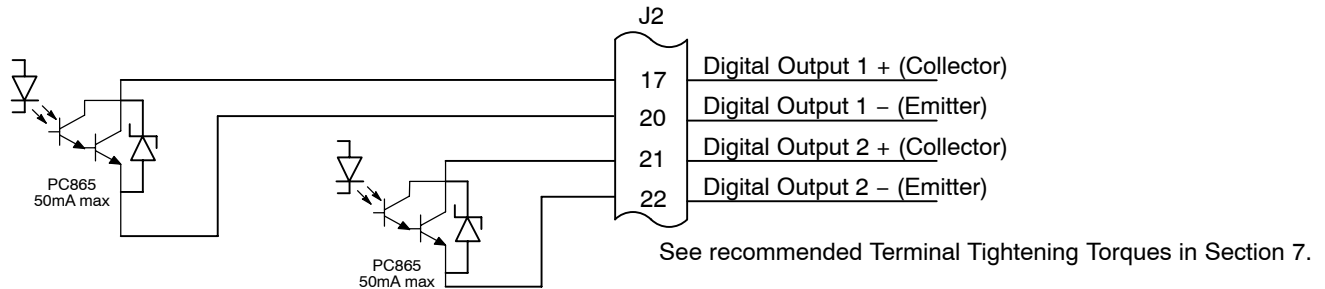

## Pre-Operation Checklist

### Check of Electrical Items

1. Verify AC line voltage at source matches control rating.
2. Inspect all power connections for accuracy, workmanship and tightness and compliance to codes.
3. Verify control and motor are grounded to each other and the control is connected to earth ground.
4. Check all signal wiring for accuracy.
5. Be certain all brake coils, contactors and relay coils have noise suppression. This should be an R-C filter for AC coils and reverse polarity diodes for DC coils. MOV type transient suppression is not adequate.

### Check of Motor and Coupling

1. Verify freedom of motion of motor shaft.
2. Verify the motor coupling is tight without backlash.
3. Verify the holding brakes if any, are properly adjusted to fully release and set to the desired torque value.

---

## **Powerup Procedure**

1. Verify that any enable inputs to J2-8 are open.
2. Turn power on. Be sure there are no faults.
3. Set the Level 1 Input block, Operating Mode to "KEYPAD".
4. Set the Level 2 Output Limits block, "OPERATING ZONE" parameter as desired (STD CONST TQ, STD VAR TQ, QUIET CONST TQ or QUIET VAR TQ).
5. Enter the following motor data in the Level 2 Motor Data block parameters:
  - Motor Rated Volt (input)
  - Motor Rated Amps (FLA)
  - Motor Rated Speed (base speed)
  - Motor Rated Frequency
  - Motor Mag Amps (no load current)
  - Encoder Counts
  - Electrical Slip Frequency
6. If external dynamic brake hardware is used, set the Level 2 Brake Adjust block "Resistor Ohms" and "Resistor Watts" parameters.
7. Go to Level 2 Motor Data block, press ENTER, at CALC MOTOR MODEL select YES (using the ▲ key) and let the control calculate preset values for the parameters that are necessary for control operation.
8. Disconnect the motor from the load (including coupling or inertia wheels). If the load cannot be disconnected, refer to Section 6 and manually tune the control. After manual tuning, perform steps 10, 11, 15 and 16.

**WARNING: The motor shaft will rotate during this procedure. Be certain that unexpected motor shaft movement will not cause injury to personnel or damage to equipment.**

9. Go to Level 2 Auto Tune block, and select, "One Step Auto Tune".
  - a. 2901 ANALOG OFFSET TRIM
  - b. 2902 ONE STEP AUTO TUNEWhen complete, proceed to step 10.

If you choose not to use the One Step Auto Tune process, manual tuning must be performed. Go to Level 2 Autotune block and perform the following:

- a. 2901 ANALOG OFFSETS TRIM
  - b. 2903 STATOR R1 TUNE
  - c. 2904 MEASURE X<sub>m</sub> (ROT)
  - d. 2905 MEASURE LEAKAGE
  - e. 2906 CURRENT LOOP TUNE
  - f. 2907 FLUX CUR TUNE
  - g. 2908 FEEDBACK TEST
  - h. 2909 SLIP FREQUENCY TUNE
  - i. 2910 SPEED LOOP TUNE
- When complete, proceed to step 10.
10. Set the Level 2 Drive Limits block, "MIN OUTPUT SPEED" parameter.
  11. Set the Level 2 Drive Limits block, "MAX OUTPUT SPEED" parameter.
  12. Remove all power from the control.
  13. Couple the motor to its load.
  14. Turn power on. Be sure no errors are displayed.
  15. Run the drive from the keypad using one of the following: the arrow keys for direct speed control, a keypad entered speed or the JOG mode.
  16. Select and program additional parameters to suit your application.

The control is now ready for use the in keypad mode. If a different operating mode is desired, refer to Section 3 Operating Modes and Section 4 Programming and Operation.



# Section 4 Programming and Operation

## Overview

The keypad is used to program the control parameters, to operate the motor and to monitor the status and outputs of the control by accessing the display options, the diagnostic menus and the fault log.

**Figure 4-1 Keypad**



**Keypad Display** - Displays status information during Local or Remote operation. It also displays information during parameter setup and fault or Diagnostic Information.

**A** - Alternates or "Toggles" between last two menu choices or function indicated by text displayed directly above key.

**ENTER** - Press ENTER to save parameter value changes and move back to the previous level in the programming menu. In the display mode the ENTER key is used to directly set the local speed reference. It is also used to select other operations when prompted by the keypad display.

**MENU** - Selects the Menu display. The following menu items are shown: Status, Diagnostics, Fault Log, Advanced Programming, and Quick Start

**REV** - When pressed, initiates a reverse direction run command.

**STOP** - Initiates a stop command.

### Display Diagnostics -

- I/O Status
- I/O Function configuration
- Modified parameters
- Control Operation Data
- Custom Units
- Fault Display - 10 Faults with Time stamp

**R** - Clear faults or undo parameter edit changes or function indicated by text displayed directly above key.

▲ - (Up Arrow), ▼ - (Down Arrow)  
◀ - (Left Arrow), ▶ - (Right Arrow)  
Moves cursor to select menu choices.

**LOCAL REMOTE** - Switches between local and remote modes.

**HELP** - Provides help at each display screen, setup parameter and fault. Press to view/close help information.

**JOG** - When pressed and held in the local mode, initiates a run command for the selected direction.

**FWD** - When pressed, initiates a forward direction run command.

**Indicator Lights** - (On indicated Key)  
STOP key with red light indicator.  
FWD key with green light indicator.  
REV key with green light indicator.  
JOG key with green light indicator.

### Display features:

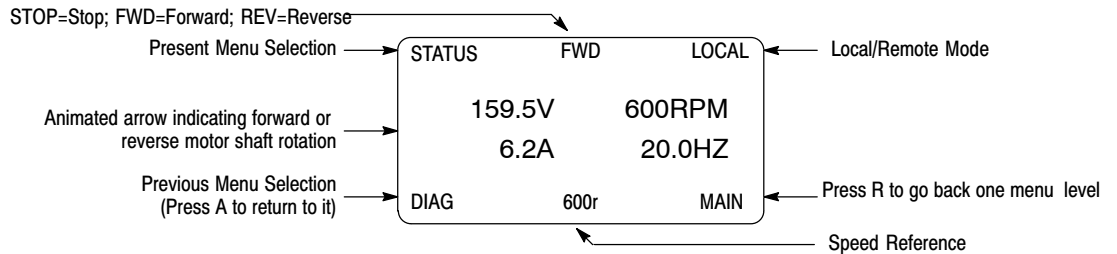

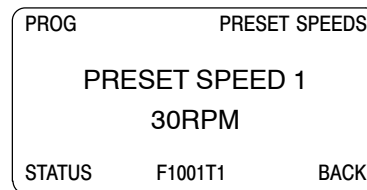

### Programming Mode ONLY Display features:

The first character of the parameter number has the following meaning:  
 F = Factory Setting (parameter value has not been changed)  
 C = Custom value set by user (not factory setting)  
 V = Parameter value may be Viewed but not changed.  
 L = Parameter value is locked, security code required.



Parameter Table used, T1, T2, T3, T4.

**Status Display Mode** The control is in the Status display mode at all times except when parameter values are changed (Programming mode).  
When AC power is applied to the control the keypad should display the status.

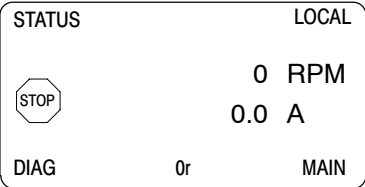
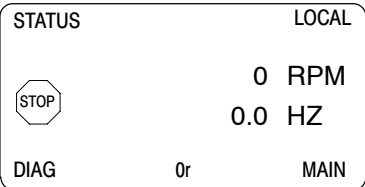
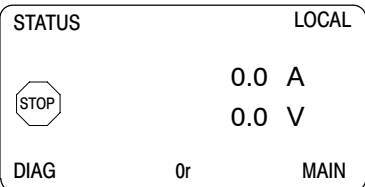
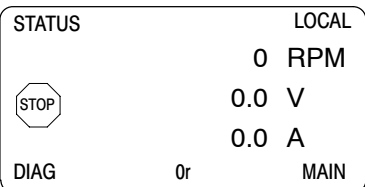
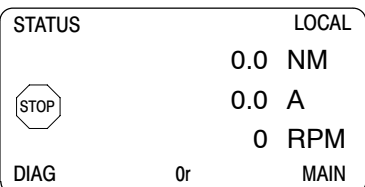
Action	Description	Display	Comments
Apply Power	Logo is displayed for a short time. The Status screen is then displayed.		
	Normal status screen at start up.		The display can be changed to several formats by pressing the ► or ◀ keys.
Press ► key	Next screen format is displayed.		
Press ► key	Next screen format is displayed.		
Press ► key	Next screen format is displayed.		
Press ► key	Next screen format is displayed.		
Press ► key	Next screen format is displayed.		



**Status Display Mode** Continued

Action	Description	Display	Comments												
Press ► key	The first screen format is displayed.	<div style="border: 1px solid black; padding: 5px; width: fit-content;"> <table style="width: 100%; border-collapse: collapse;"> <tr> <td style="width: 33%;">STATUS</td> <td style="width: 33%;">STOP</td> <td style="width: 33%;">LOCAL</td> </tr> <tr> <td style="text-align: center;">0.0V</td> <td></td> <td style="text-align: center;">0RPM</td> </tr> <tr> <td style="text-align: center;">0.0A</td> <td></td> <td style="text-align: center;">0.0HZ</td> </tr> <tr> <td>DIAG</td> <td style="text-align: center;">or</td> <td>MAIN</td> </tr> </table> </div>	STATUS	STOP	LOCAL	0.0V		0RPM	0.0A		0.0HZ	DIAG	or	MAIN	
STATUS	STOP	LOCAL													
0.0V		0RPM													
0.0A		0.0HZ													
DIAG	or	MAIN													
Press FWD key	Motor begins to rotate in the forward direction at the preset speed.	<div style="border: 1px solid black; padding: 5px; width: fit-content;"> <table style="width: 100%; border-collapse: collapse;"> <tr> <td style="width: 33%;">STATUS</td> <td style="width: 33%;">FWD</td> <td style="width: 33%;">LOCAL</td> </tr> <tr> <td style="text-align: center;">159.5V</td> <td></td> <td style="text-align: center;">600RPM</td> </tr> <tr> <td style="text-align: center;">0.2A</td> <td></td> <td style="text-align: center;">20.0HZ</td> </tr> <tr> <td>DIAG</td> <td style="text-align: center;">600r</td> <td>MAIN</td> </tr> </table> </div>	STATUS	FWD	LOCAL	159.5V		600RPM	0.2A		20.0HZ	DIAG	600r	MAIN	
STATUS	FWD	LOCAL													
159.5V		600RPM													
0.2A		20.0HZ													
DIAG	600r	MAIN													

**Menu Display** After power-up the display shows the Status screen. Press the Menu key to display menu options.

Action	Description	Display	Comments																					
Status Display		<div style="border: 1px solid black; padding: 5px; width: fit-content;"> <table style="width: 100%; border-collapse: collapse;"> <tr> <td style="width: 33%;">STATUS</td> <td style="width: 33%;">STOP</td> <td style="width: 33%;">LOCAL</td> </tr> <tr> <td style="text-align: center;">0.0V</td> <td></td> <td style="text-align: center;">0RPM</td> </tr> <tr> <td style="text-align: center;">0.0A</td> <td></td> <td style="text-align: center;">0.0HZ</td> </tr> <tr> <td>DIAG</td> <td style="text-align: center;">or</td> <td>MAIN</td> </tr> </table> </div>	STATUS	STOP	LOCAL	0.0V		0RPM	0.0A		0.0HZ	DIAG	or	MAIN										
STATUS	STOP	LOCAL																						
0.0V		0RPM																						
0.0A		0.0HZ																						
DIAG	or	MAIN																						
Press Menu	Displays top level menu options.	<div style="border: 1px solid black; padding: 5px; width: fit-content;"> <table style="width: 100%; border-collapse: collapse;"> <tr> <td style="width: 33%;">STATUS</td> <td style="width: 33%;"></td> <td style="width: 33%;"></td> </tr> <tr> <td style="background-color: #cccccc;">QUICK SETUP</td> <td></td> <td></td> </tr> <tr> <td>PROGRAMMING</td> <td></td> <td></td> </tr> <tr> <td>EVENT LOG</td> <td></td> <td></td> </tr> <tr> <td>DIAGNOSTICS</td> <td></td> <td></td> </tr> <tr> <td>DISPLAY OPTIONS</td> <td></td> <td></td> </tr> <tr> <td>DIAG</td> <td></td> <td>BACK</td> </tr> </table> </div>	STATUS			QUICK SETUP			PROGRAMMING			EVENT LOG			DIAGNOSTICS			DISPLAY OPTIONS			DIAG		BACK	Press ▲ or ▼ to move cursor over the desired selection the press “Enter” to select and display the selection.
STATUS																								
QUICK SETUP																								
PROGRAMMING																								
EVENT LOG																								
DIAGNOSTICS																								
DISPLAY OPTIONS																								
DIAG		BACK																						

## Quick Setup

From the Menu display screen, select Quick Setup and press Enter.

**Parameter Status.** All programmable parameters are displayed with an “F” at the bottom center of the display. “F” means it is the factory setting value. “C” means it is a custom value set by the user. “V” means the parameter value may be viewed but not changed while the motor is operating. If the parameter is displayed with an “L”, the value is locked and may not be changed until the security code is entered.

Action	Description	Display	Comments
Quick Setup Display	Control type display. The parameter number “1601” is given at the bottom center of the display. “F”1601 indicates it is at the factory setting and has not been changed.	<pre> QSETUP          MOTOR CONTROL                 CONTROL TYPE                 Closed Vector STATUS          F1601T1    BACK           </pre>	Press Enter to select the parameter and press the ▲ or ▼ keys to change the preset value to a different control type. Press enter when finished to exit and save the new value or R to exit without saving.
Press ► to go to the next Quick Setup screen.		<pre> QSETUP          MOTOR DATA                 MOTOR RATED VOLT                 240.0 V STATUS          F2401T1    BACK           </pre>	T1 indicates the Table Number or the parameter list in use. Four parameter tables are available, T1, T2, T3 or T4 (See Level 2, Drive Config, Active Param Table parameter P2108.)
Press ► to go to the next Quick Setup screen.		<pre> QSETUP          MOTOR DATA                 MOTOR RATED AMPS                 9.6 A STATUS          F2402T1    BACK           </pre>	
Press ► to go to the next Quick Setup screen.		<pre> QSETUP          MOTOR DATA                 MOTOR MAG AMPS                 3.1 A STATUS          F2405T1    BACK           </pre>	
Press ► to go to the next Quick Setup screen.		<pre> QSETUP          MOTOR DATA                 MOTOR RATED SPD                 1754 RPM STATUS          F2403T1    BACK           </pre>	
Press ► to go to the next Quick Setup screen.		<pre> QSETUP          MOTOR DATA                 MOTOR RATED FREQ                 60.00 HZ STATUS          F2404T1    BACK           </pre>	

**Quick Setup** Continued

Action	Description	Display	Comments
Press ► to go to the next Quick Setup screen.		<div style="border: 1px solid black; padding: 5px;"> <p style="text-align: center;">QSETUP                      MOTOR DATA</p> <p style="text-align: center;"><b>CALC MOTOR MODEL</b></p> <p style="text-align: center;">No</p> <p style="text-align: center;">STATUS      F2413T1      BACK</p> </div>	
Press ► to go to the next Quick Setup screen.		<div style="border: 1px solid black; padding: 5px;"> <p style="text-align: center;">QSETUP                      MOTOR DATA</p> <p style="text-align: center;"><b>ENCODER SOURCE</b></p> <p style="text-align: center;">Daughter FDBK</p> <p style="text-align: center;">STATUS      F2409T1      BACK</p> </div>	
Press ► to go to the next Quick Setup screen.		<div style="border: 1px solid black; padding: 5px;"> <p style="text-align: center;">QSETUP                      MOTOR DATA</p> <p style="text-align: center;"><b>ENCODER COUNTS</b></p> <p style="text-align: center;">1024 PPR</p> <p style="text-align: center;">STATUS      F2408T1      BACK</p> </div>	
Press ► to go to the next Quick Setup screen.		<div style="border: 1px solid black; padding: 5px;"> <p style="text-align: center;">QSETUP                      AUTO-TUNE</p> <p style="text-align: center;"><b>ANA OFFSET TRIM</b></p> <p style="text-align: center;">No</p> <p style="text-align: center;">STATUS      F2901T1      BACK</p> </div>	
Press ► to go to the next Quick Setup screen.		<div style="border: 1px solid black; padding: 5px;"> <p style="text-align: center;">QSETUP                      AUTO-TUNE</p> <p style="text-align: center;"><b>ONE-STEP TUNING</b></p> <p style="text-align: center;">No</p> <p style="text-align: center;">STATUS      F2902T1      BACK</p> </div>	
Press ► to go to the next Quick Setup screen.		<div style="border: 1px solid black; padding: 5px;"> <p style="text-align: center;">QSETUP                      INPUT SETUP</p> <p style="text-align: center;"><b>OPERATING MODE</b></p> <p style="text-align: center;">Keypad</p> <p style="text-align: center;">STATUS      F1401T1      BACK</p> </div>	
Press ► to go to the next Quick Setup screen.		<div style="border: 1px solid black; padding: 5px;"> <p style="text-align: center;">QSETUP                      RAMP RATES</p> <p style="text-align: center;"><b>ACCEL TIME 1</b></p> <p style="text-align: center;">3.0 SEC</p> <p style="text-align: center;">STATUS      F1101T1      BACK</p> </div>	
Press ► to go to the next Quick Setup screen.		<div style="border: 1px solid black; padding: 5px;"> <p style="text-align: center;">QSETUP                      RAMP RATES</p> <p style="text-align: center;"><b>DECEL TIME 1</b></p> <p style="text-align: center;">3.0 SEC</p> <p style="text-align: center;">STATUS      F1104T1      BACK</p> </div>	

---

**Quick Setup** Continued

Action	Description	Display	Comments
Press ► to go to the next Quick Setup screen.		<div style="border: 1px solid black; padding: 5px; text-align: center;"><p>QSETUP                      DRIVE LIMITS</p><p>MIN OUTPUT SPEED</p><p>0 RPM</p><p>STATUS            F2002T1            BACK</p></div>	
Press ► to go to the next Quick Setup screen.		<div style="border: 1px solid black; padding: 5px; text-align: center;"><p>QSETUP                      DRIVE LIMITS</p><p>MAX OUTPUT SPEED</p><p>1800 RPM</p><p>STATUS            F2003T1            BACK</p></div>	
Press ► to go to the next Quick Setup screen.		<div style="border: 1px solid black; padding: 5px; text-align: center;"><p>QSETUP</p><p>END OF</p><p>QUICK SET UP</p><p>STATUS                                      BACK</p></div>	

**Quick Setup** Continued

**How to Change a Value**

These are the Quick Setup screens. To change a value, simply display the desired screen and press Enter and change the value. For example:

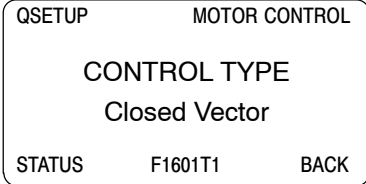
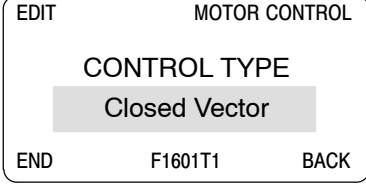
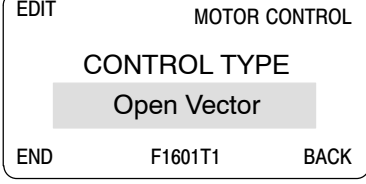
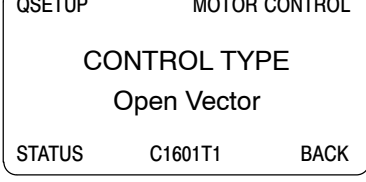
Action	Description	Display	Comments
Press ► to go to the next Quick Setup screen.	1601 indicates the parameter number and F indicates it is the factory value.		
Press Enter to choose parameter value and edit.			Press "R" to exit EDIT mode without saving changes.
Press the ► or ◀ keys to change parameter value.			
Press Enter to save the parameter value and exit.			

When editing a parameter value, the function of the "A" key (previous parameter block) shown in the lower left of the display changes to one of the following to help select the parameter value:

- TOP Press "A" to display and select the first value in the list of parameter values.  
When the first parameter value is displayed, press Enter or scroll to select a different value.
- END Press "A" to display and select the last value in the list of parameter values.  
When the last parameter value is displayed, press Enter or scroll to select a different value.
- DEF Press "A" to display and select the Factory Setting value.
- PREV Press "A" to display and select previous value.
- MIN Press "A" to display and select minimum parameter value.
- MAX Press "A" to display and select maximum parameter value.

Note: When END is displayed, Press "A" will display the last value in the list but then TOP or DEF is displayed. The "A" key allows you to quickly move the large lists of parameter choices. The value is not selected until you press "Enter".

## Save Parameter Values

The keypad keys and display work with the memory of the control. When a parameter value is displayed, the displayed value is the value stored in control memory. The changes are written to non-volatile memory and are stored even when power is removed. Normal control operation can resume when power is restored.

Keypad memory is only used to backup the four parameter tables stored in control memory. This means that after the parameters are configured for the application and the control operation is as desired, a copy of the parameters can be saved to keypad memory as a backup copy. This backup copy can be restored at any time. This is useful to restore program operation after a firmware update or to make several controls operate the same. It prevents having to make the changes to each control individually.

Action	Description	Display	Comments
Press Menu	Go to the Level 1 Keypad Setup block.	<pre> PRESET SPEEDS RAMP RATES JOG SETTINGS KEYPAD SETUP INPUT SETUP  STATUS          BACK           </pre>	Press "Enter" to select.
Press Enter to edit Keypad Setup parameters.	Scroll to PARAMS TO KEYPAD	<pre> PROG          KEYPAD SETUP  PARAMS TO KEYPAD           No  STATUS  F1310  BACK           </pre>	Press "Enter" to change parameter value.  Note that T1 is missing from the parameter number. It is not part of the stored parameter table values T1, T2, T3 and T4.
Press Enter to edit parameter.		<pre> edit          KEYPAD SETUP  PARAMS TO KEYPAD           Yes  STATUS  F1310  BACK           </pre>	Press ▲ to change value to YES.
Press Enter to load the parameter table values from control memory to keypad memory.		<pre> PROG          KEYPAD SETUP  PARAMS TO KEYPAD           No  STATUS  F1310  BACK           </pre>	Press "R" to return to Keypad Setup menu.

A copy of all four parameter tables have now been saved to non-volatile keypad memory.

## Restore Parameter Values

The keypad keys and display work with the memory of the control. When a parameter value is displayed, the displayed value is the value stored in control memory. The changes are written to non-volatile memory and are stored even when power is removed. Normal control operation can resume when power is restored.

Keypad memory is only used to backup the four parameter tables stored in control memory. This means that after the parameters are configured for the application and the control operation is as desired, a copy of the parameters can be saved to keypad memory as a backup copy. This backup copy can be restored at any time. This is useful to restore program operation after a firmware update or to make several controls operate the same. It prevents having to make the changes to each control individually.

Action	Description	Display	Comments
Press Menu	Go to the Level 1 Keypad Setup block.	<pre> PRESET SPEEDS RAMP RATES JOG SETTINGS KEYPAD SETUP INPUT SETUP  STATUS                BACK                     </pre>	Press "Enter" to select.
Press Enter to edit Keypad Setup parameters.	Scroll to KEYPAD TO PARAMS	<pre> PROG                KEYPAD SETUP  KEYPAD TO PARAMS  No  STATUS  F1310      BACK                     </pre>	Press "Enter" to change parameter value.
Press Enter to edit parameter.		<pre> edit                KEYPAD SETUP  KEYPAD TO PARAMS  Yes  STATUS  F1310      BACK                     </pre>	Press ▲ to change value to YES.
Press Enter to load the parameter table values from keypad memory to control memory.		<pre> PROG                KEYPAD SETUP  KEYPAD TO PARAMS  No  STATUS  F1310      BACK                     </pre>	Press "R" to return to Keypad Setup menu.



A copy of all four parameter tables have now been restored to non-volatile control memory.

## Programming

From the Menu display screen, select Programming and press Enter.  
The Program Mode is used to:

1. Enter motor data.
2. Auto Tune the motor.
3. Customize the drive (Control and Motor) parameters to your application.

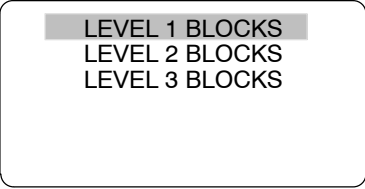
**Parameter Status.** All programmable parameters are displayed with its parameter number shown at the bottom center of the display. "F" means it is the factory setting value. "C" means it is a custom value set by the user. "V" means the parameter value may be viewed but not changed while the motor is operating. If the parameter is displayed with an "L", the value is locked and may not be changed until the security code is entered.

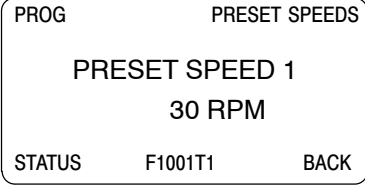
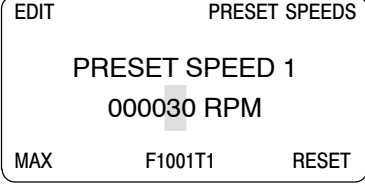
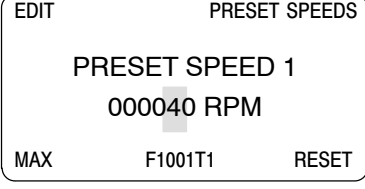
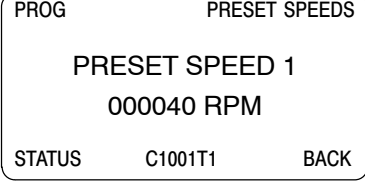
Action	Description	Display	Comments
Programming Display	Top Level Programming menu.		Press enter to program level 1 block parameters. or Press ▼ to go onto Level 2 blocks Press ▼ again to go to Level 3 blocks.
Press Enter to edit Level 1 parameters.	Top of Level 1 programming Block 1 menu.		Press ▼ to scroll to next level 1 parameter.
Press Enter to select Preset Speeds.	Preset speed 1 value display.		Press ► to go to next Preset Speed parameter.
Press Enter to edit Preset Speed 1.	Press ▲ or ▼ to increase or decrease the value highlighted by the cursor.		Press ► or ◀ to move cursor. Press "A" to select the maximum allowable speed.
	Press ▲ to increase the value.		Press R to exit editing the value without saving or press Enter to exit and save the new value.
Press Enter to save the new value and stop editing.			Press R to return to previous screen. Press A to go to Status screen.

Parameter values in other Level 1, 2 and 3 blocks can be selected and edited in the same way.



## Event Log

From the Menu display screen, select Event Log and press enter. Trace is used to display control conditions present at the time the fault occurred. A separate trace log is recorded for each event. This is described in Section 5 of this manual.

Action	Description	Display	Comments
Event Log Display	Displays error name, Entry # and time the error occurred. LOW INITIAL BUS 0 Date Time Entry # DD/MM/YY HH:MM 0-9	<pre> EV. LOG    STOP    LOCAL           LOW INITIAL BUS           0  20-May-05  09:42:00           STATUS    TRACE           </pre>	Press ▲ or ▼ to view next entry.  Press R to view Trace log. Press A to return to Status Menu.  Note: Trace is described in Section 5 of this manual.

Trace is used to display control conditions present at the time the fault occurred. Input states, Output states, various voltage and current values etc. can be viewed to help understand the cause of the fault condition. See Section 5 of this manual for more information.

## Diagnostics

From the Menu display screen, select Diagnostics and press enter. These are read only values.

Action	Description	Display	Comments
Diagnostic Display	Displays software version, hp, volts and Amp/Volt ratings.	<pre> DIAG      STOP    LOCAL           ZHH-1.XX           RATED HP      3HP           RATED VOLTS  240.0V           RATED A/V    4.0A/V           EV. LOG      0r    MAIN           </pre>	Press ► or ◀ to go to the next or previous Diagnostic screen.  Press R to return to previous menu.
Press ► to display next group.		<pre> DIAG      STOP    LOCAL           ZHH-1.XX           RATED CURRE   9.6A           RATED PK CU   16.8A           EV. LOG      0r    MAIN           </pre>	Press ► or ◀ to go to the next or previous Diagnostic screen.  Press R to return to previous menu.
Press ► to display next group.	Displays real time clock values (date and time) and total run time since installation.  Press ENTER to set date and time.	<pre> DIAG      STOP    LOCAL           REAL TIME CLOCK           May 20, 2005           22:7:35           RUN TIMER     474.1HR           EV. LOG      0r    MAIN           </pre>	Press ► or ◀ to go to the next or previous Diagnostic screen.  Press R to return to previous menu.
Press ► to display next group.	Displays energy cost (based on parameter # 2305 value).	<pre> DIAG      STOP    LOCAL           ENERGY           EST POWER     0.00KW           EST ENERGY   0.0KWH           EST COST      0.0\$           EV. LOG      0r    MAIN           </pre>	Press ► or ◀ to go to the next or previous Diagnostic screen.  Press R to return to previous menu.  Press A to go to Status screen.
Press ► to display next group.	Diagnostic Analog Input values display.	<pre> DIAG      STOP    LOCAL           ANALOG INPUTS           ANA IN1      1.3v           ANA IN2      0.0v           EV. LOG      0r    MAIN           </pre>	Press ► or ◀ to go to the next or previous Diagnostic screen.  Press R to return to previous menu.

## Diagnosics Continued

Action	Description	Display	Comments																		
Press ► to display next group.	Diagnostic Analog Output values display.	<table border="1"> <tr> <td>DIAG</td> <td>STOP</td> <td>LOCAL</td> </tr> <tr> <td colspan="3" style="text-align: center;">ANALOG OUTPUTS</td> </tr> <tr> <td>ANA OUT1</td> <td></td> <td>0.0V</td> </tr> <tr> <td>ANA OUT2</td> <td></td> <td>0.0V</td> </tr> <tr> <td>EV. LOG</td> <td>0r</td> <td>MAIN</td> </tr> </table>	DIAG	STOP	LOCAL	ANALOG OUTPUTS			ANA OUT1		0.0V	ANA OUT2		0.0V	EV. LOG	0r	MAIN	<p>Press ► or ◀ to go to the next or previous Diagnostic screen.</p> <p>Press R to return to previous menu.</p>			
DIAG	STOP	LOCAL																			
ANALOG OUTPUTS																					
ANA OUT1		0.0V																			
ANA OUT2		0.0V																			
EV. LOG	0r	MAIN																			
Press ► to display next group.	Revolutions are full rotations. Counts are encoder counts (partial revolutions)	<table border="1"> <tr> <td>DIAG</td> <td>STOP</td> <td>LOCAL</td> </tr> <tr> <td colspan="3" style="text-align: center;">POSITION COUNTER</td> </tr> <tr> <td>REVOLUTIONS</td> <td></td> <td>0CNT</td> </tr> <tr> <td>COUNTS</td> <td></td> <td>0CNT</td> </tr> <tr> <td>EV. LOG</td> <td>0r</td> <td>MAIN</td> </tr> </table>	DIAG	STOP	LOCAL	POSITION COUNTER			REVOLUTIONS		0CNT	COUNTS		0CNT	EV. LOG	0r	MAIN	<p>Press ► or ◀ to go to the next or previous Diagnostic screen.</p> <p>Press R to return to previous menu.</p>			
DIAG	STOP	LOCAL																			
POSITION COUNTER																					
REVOLUTIONS		0CNT																			
COUNTS		0CNT																			
EV. LOG	0r	MAIN																			
Press ► to display next group.	Diagnostic installed Option Card identification display.	<table border="1"> <tr> <td>DIAG</td> <td>STOP</td> <td>LOCAL</td> </tr> <tr> <td colspan="3" style="text-align: center;">OPTION BOARDS</td> </tr> <tr> <td>OPTION 1</td> <td></td> <td>NONE</td> </tr> <tr> <td>OPTION 2</td> <td></td> <td>NONE</td> </tr> <tr> <td>FEEDBACK</td> <td></td> <td>ENCODER</td> </tr> <tr> <td>EV. LOG</td> <td>0r</td> <td>MAIN</td> </tr> </table>	DIAG	STOP	LOCAL	OPTION BOARDS			OPTION 1		NONE	OPTION 2		NONE	FEEDBACK		ENCODER	EV. LOG	0r	MAIN	<p>Press ► or ◀ to go to the next or previous Diagnostic screen.</p> <p>Press R to return to previous menu.</p> <p>Press A to go to Status screen.</p>
DIAG	STOP	LOCAL																			
OPTION BOARDS																					
OPTION 1		NONE																			
OPTION 2		NONE																			
FEEDBACK		ENCODER																			
EV. LOG	0r	MAIN																			
Press ► to display next group.	Displays keypad software version.	<table border="1"> <tr> <td>DIAG</td> <td>STOP</td> <td>LOCAL</td> </tr> <tr> <td colspan="3" style="text-align: center;">KEYPAD VERSION</td> </tr> <tr> <td>KEYPAD SOF</td> <td>1.XX</td> <td>03/0</td> </tr> <tr> <td>EV. LOG</td> <td>0r</td> <td>MAIN</td> </tr> </table>	DIAG	STOP	LOCAL	KEYPAD VERSION			KEYPAD SOF	1.XX	03/0	EV. LOG	0r	MAIN							
DIAG	STOP	LOCAL																			
KEYPAD VERSION																					
KEYPAD SOF	1.XX	03/0																			
EV. LOG	0r	MAIN																			
Press ► to display next group.		<table border="1"> <tr> <td>DIAG</td> <td>STOP</td> <td>LOCAL</td> </tr> <tr> <td colspan="3" style="text-align: center;">POWER BASE</td> </tr> <tr> <td>BUS VOLTAGE</td> <td></td> <td>333.9V</td> </tr> <tr> <td>DRIVE TEMP</td> <td></td> <td>26.1C</td> </tr> <tr> <td>OVERLOAD LE</td> <td></td> <td>100.0%</td> </tr> <tr> <td>EV. LOG</td> <td>0r</td> <td>MAIN</td> </tr> </table>	DIAG	STOP	LOCAL	POWER BASE			BUS VOLTAGE		333.9V	DRIVE TEMP		26.1C	OVERLOAD LE		100.0%	EV. LOG	0r	MAIN	<p>Press ► or ◀ to go to the next or previous Diagnostic screen.</p> <p>Press R to return to previous menu.</p>
DIAG	STOP	LOCAL																			
POWER BASE																					
BUS VOLTAGE		333.9V																			
DRIVE TEMP		26.1C																			
OVERLOAD LE		100.0%																			
EV. LOG	0r	MAIN																			
Press ► to display next group.	Displays active operating mode settings.	<table border="1"> <tr> <td>DIAG</td> <td>STOP</td> <td>LOCAL</td> </tr> <tr> <td colspan="3" style="text-align: center;">OPERATING MODE</td> </tr> <tr> <td colspan="3" style="text-align: center;">Keypad</td> </tr> <tr> <td colspan="3" style="text-align: center;">Speed</td> </tr> <tr> <td colspan="3" style="text-align: center;">Closed Vector</td> </tr> <tr> <td>EV. LOG</td> <td>0r</td> <td>MAIN</td> </tr> </table>	DIAG	STOP	LOCAL	OPERATING MODE			Keypad			Speed			Closed Vector			EV. LOG	0r	MAIN	
DIAG	STOP	LOCAL																			
OPERATING MODE																					
Keypad																					
Speed																					
Closed Vector																					
EV. LOG	0r	MAIN																			
Press ► to display next group.	Note: User 24V is the internal power source voltage. (Does not measure external supplies).	<table border="1"> <tr> <td>DIAG</td> <td>STOP</td> <td>LOCAL</td> </tr> <tr> <td colspan="3" style="text-align: center;">DIGITAL I/O</td> </tr> <tr> <td>INPUTS</td> <td></td> <td>100000000</td> </tr> <tr> <td>OUTPUTS</td> <td></td> <td>0110</td> </tr> <tr> <td>USER 24V</td> <td></td> <td>24.9V</td> </tr> <tr> <td>EV. LOG</td> <td>0r</td> <td>MAIN</td> </tr> </table>	DIAG	STOP	LOCAL	DIGITAL I/O			INPUTS		100000000	OUTPUTS		0110	USER 24V		24.9V	EV. LOG	0r	MAIN	<p>Press ► or ◀ to go to the next or previous Diagnostic screen.</p> <p>Press R to return to previous menu.</p>
DIAG	STOP	LOCAL																			
DIGITAL I/O																					
INPUTS		100000000																			
OUTPUTS		0110																			
USER 24V		24.9V																			
EV. LOG	0r	MAIN																			
Press ► to display next group.	Note: This screen does not appear if Level 2 Process Control, Process type is set to None.	<table border="1"> <tr> <td>DIAG</td> <td>STOP</td> <td>LOCAL</td> </tr> <tr> <td colspan="3" style="text-align: center;">PROC CONTROL PID</td> </tr> <tr> <td></td> <td>0.0HZ</td> <td>0.0FF</td> </tr> <tr> <td></td> <td>0.0SP</td> <td>0.0FB</td> </tr> <tr> <td>EV. LOG</td> <td>0r</td> <td>MAIN</td> </tr> </table>	DIAG	STOP	LOCAL	PROC CONTROL PID				0.0HZ	0.0FF		0.0SP	0.0FB	EV. LOG	0r	MAIN	<p>Press ► or ◀ to go to the next or previous Diagnostic screen.</p> <p>Press R to return to previous menu.</p>			
DIAG	STOP	LOCAL																			
PROC CONTROL PID																					
	0.0HZ	0.0FF																			
	0.0SP	0.0FB																			
EV. LOG	0r	MAIN																			

## Display Options

From the Menu display screen, select Display Options and press enter to view or change values.

Action	Description	Display	Comments
			Press "Enter" to change parameter value. Press ► or ◀ to display next screen.  Press "R" to return to previous menu.
			Press "Enter" to change parameter value. Press ► or ◀ to display next screen.  Press "R" to return to previous menu.

## Operating the Control from the Keypad

To activate the LOCAL Mode, first press the "STOP" key (if enabled).

Note: Pressing the keypad STOP key (if enabled) will automatically issue a motor stop command and change to LOCAL mode.

Selection of LOCAL Mode overrides any remote or serial control inputs except the External Trip input, Local Enable Input or STOP input.

The control can operate the motor from the keypad in two ways.

1. JOG Command.
2. Speed adjustment with Keypad entered values and/or Keypad Up/Down arrow keys.

Note: If the level 1, input block operating mode parameter is set to Keypad, then no other means of operation is permitted other than from the keypad.

## Accessing the Keypad JOG Command

Action	Description	Display	Comments
Status Display			
Press JOG key Next, press and hold the FWD or REV key	The JOG LED will light indicating the JOG mode is active. Holding the FWD or REV key starts JOG operation. Releasing FWD or REV key will terminate motor rotation.		To change Jog Speed, Edit Level 1 parameter 1201 (Jog Speed).  Press STOP key to terminate JOG mode.

## Speed Adjustment using Local Speed Reference

Action	Description	Display	Comments
At the Status Display, press ENTER key to access Local Speed Reference.		<pre> EDIT                                LOCAL REFs LOC SPEED REF 000000 RPM MAX          F0201          RESET           </pre>	
		<pre> EDIT                                LOCAL REFs LOC SPEED REF 000000 RPM DIAG          F0201          BACK           </pre>	Press <b>▶</b> or <b>◀</b> to move cursor. Press <b>▲</b> or <b>▼</b> to increase or decrease value at cursor. Press ENTER when finished and save the new value.
Press FWD or REV key.	The control will turn the motor shaft at the local speed ref speed.	<pre> EDIT                                LOCAL REFs LOC SPEED REF 000300 RPM DIAG          C0201          BACK           </pre>	Press <b>▶</b> or <b>◀</b> to move cursor. Press <b>▲</b> or <b>▼</b> to increase or decrease value at cursor. Press ENTER when finished and save the new value.
		<pre> STATUS          FWD          LOCAL 159.5V          300RPM 0.2A           10.0HZ DIAG          300r          BACK           </pre>	Press STOP key to terminate local speed mode. Press <b>▲</b> or <b>▼</b> to increase or decrease motor speed during rotation.

**Table 4-1 List of Parameters** (Version 1.01)

<b>Level 1 Blocks</b>			
<b>Preset Speeds</b>	<b>Keypad Setup</b>	<b>Output Setup</b>	<b>Communication</b>
PRESET SPEED 1	STOP KEY	DIGITAL OUTPUT 1	BAUD RATE
PRESET SPEED 2	STOP MODE	DIGITAL OUTPUT 2	PARITY
PRESET SPEED 3	RUN FORWARD	RELAY OUTPUT 1	STOP BITS
PRESET SPEED 4	RUN REVERSE	RELAY OUTPUT 2	DRIVE ADDRESS
PRESET SPEED 5	SWITCH ON FLY	ANALOG OUT1 TYPE	IP ADDRESS
PRESET SPEED 6	LOCAL HOT START	ANALOG OUT1 SIGNAL	SUBNET MASK
PRESET SPEED 7	SPEED INCREMENT	ANALOG OUT2 SIGNAL	GATEWAY MASK
PRESET SPEED 8	INIT LOCAL SPEED	ANALOG OUT1 GAIN	IP ADDRESS SOURCE
PRESET SPEED 9	SET SPEED	ANALOG OUT2 TYPE	
PRESET SPEED 10	PARAMS TO KEYPAD	ANALOG OUT2 GAIN	
PRESET SPEED 11	KEYPAD TO PARAMS	ZERO SPD SET PT	
PRESET SPEED 12	KEYPAD CONTRAST	AT SPEED BAND	
PRESET SPEED 13	BACKLIGHT	SET SPEED POINT	
PRESET SPEED 14	③ LOCAL TORQUE MODE	OVERLOAD SET POINT	
PRESET SPEED 15	③ LOCAL TORQUE REFERENCE	UNDERLOAD SET POINT	
		CALIBRATE ANA OUT	
<b>Ramp Rates</b>	<b>Input Setup</b>	<b>Motor Control</b>	
ACCEL TIME 1	OPERATING MODE	CONTROL TYPE	
START S-ACCEL 1	COMMAND SOURCE	CONTROL BASE SPEED	
END S-ACCEL 1	ANA IN1 TYPE	② CONTROL BASE VOLT	
DECEL TIME 1	ANA IN1 INVERT	② STATIC BOOST	
START S-DECEL 1	ANA IN1 GAIN	② DYNAMIC BOOST CUT IN	
END S-DECEL 1	ANA IN1 OFFSET	② DYNAMIC BOOST	
ACCEL TIME 2	ANA IN1 FILTER	② V/F EFFICIENCY	
START S-ACCEL 2	ANA IN2 TYPE	② V/F PROFILE	
END S-ACCEL 2	ANA IN2 INVERT	② 3 POINT METHOD	
DECEL TIME 2	ANA IN2 GAIN	② 3 POINT VOLTAGE	
START S-DECEL 2	ANA IN2 OFFSET	② 3 POINT FREQUENCY	
END S-DECEL 2	ANA IN2 DEADBAND	② SLIP COMP ENABLE	
	ANA IN2 FILTER	① FEEDBACK ALIGN	
<b>Jog Settings</b>	③ EXT. CURRENT LIMIT	① FEEDBACK FILTER	
JOG SPEED	③ CURRENT LIMIT SOURCE	③ CURRENT PROP GAIN	
JOG ACCEL TIME		③ CURRENT INTEGRAL GAIN	
JOG START S-ACCEL		③ SPEED PROP GAIN	
JOG END S-ACCEL		③ SPEED INTEGRAL GAIN	
JOG DECEL TIME		③ SPEED DIFFERENTIAL GAIN	
JOG START S-DECEL		① POSITION GAIN	
JOG END S-DECEL		③ A.S. PROP GAIN	
JOG FORWARD		③ A.S. INTEGRAL GAIN	
JOG REVERSE		③ MOTOR Xm	
		③ MOTOR R1	
		③ MOTOR X1	
		③ ROTOR TIME CONSTANT	
		③ MOTOR R2	
		③ MOTOR X2	

- ① Only available or active in Closed Loop Vector mode. Ignore these parameters for Open Loop Vector and V/F modes.  
 ② Only available or active in V/F mode. Ignore these parameters for Open Loop Vector mode.  
 ③ Only available or active in either Vector mode. Ignore these parameters for V/F mode.

**Table 4-1 List of Parameters** Continued

<b>Level 2 Blocks</b>			
<b>Drive Limits</b>	<b>Miscellaneous</b>	<b>Brake Adjust</b>	<b>② Synchro Start</b>
OPERATING ZONE	AUTO RESTART	RESISTOR OHMS	② SYNC START FWD
MIN OUTPUT SPEED	RESTARTS/HOUR	RESISTOR WATTS	② SYNC START REV
MAX OUTPUT SPEED	RESTART DELAY	RESISTOR TTC	② SYNC AT MAX FREQ
PWM FREQUENCY	PWM TECHNIQUE	② DC BRAKE VOLTS	② SYNCHRO SCAN V/F
③ CUR RATE LIMIT	COST OF ENERGY	② DC BRAKE TRIGGER	② SYNC SETUP TIME
PEAK CURRENT LEVEL	RESET ENERGY	② BRAKE ON STOP	② SYNC SCAN TIME
REGEN TORQUE LIMIT	① HOMING SPEED	② BRAKE ON REVERSE	② SYNC RECOVER
	① HOMING OFFSET	② STOP BRAKE TIME	
<b>Drive Configure</b>	FILTER TYPE	② BRAKE ON START	<b>Auto Tune</b>
SPEED UNITS	FILTER SOURCE	② START BRAKE TIME	ANALOG OFFSET TRIM
FACTORY SETTINGS	FILTER DESTINATION		③ ONE-STEP TUNING
CLEAR FAULT LOG	FILTER CUTOFF	<b>Process Control</b>	STATOR R1 TUNE
SECURITY	NOTCH CENTER FREQUENCY	PROCESS TYPE	③ MEASURE Xm (ROT)
ACCESS TIMEOUT	NOTCH BAND	PROCESS FEEDFORWARD	③ MEASURE LEAKAGE
ACCESS CODE	<b>Motor Data</b>	PROCESS FEEDBACK	③ CURRENT LOOP TUNE
ACTIVE PARAMETER TABLE	MOTOR RATED VOLT	SETPOINT SOURCE	③ FLUX CURRENT TUNE
DEAD TIME COMP	MOTOR RATED AMPS	SETPOINT COMMAND	① FEEDBACK TEST
POWER INPUT	MOTOR RATED SPEED	SETPOINT BAND	① SLIP FREQUENCY TUNE
	MOTOR RATED FREQUENCY	PROCESS PROP GAIN	① SPEED LOOP TUNE
<b>Drive Protect</b>	MOTOR MAG AMPS	PROCESS INT GAIN	
EXTERNAL TRIP	① ENCODER COUNTS	PROCESS INT CLAMP	
③ FOLLOWING ERROR	① ENCODER SOURCE	PROCESS DIFF GAIN	
③ TORQUE PROVING	① ENCODER TYPE	ACC/DEC ADJUST	
① ENCODER LOSS	① RESOLVER SPEED	ERROR SWITCH POINT	
OVERLOAD	ELECT SLIP FREQUENCY	PROCESS SLEEP BAND	
① ENCODER SENSE	CALCULATE MOTOR MODEL		
OVER TEMPERATURE		<b>② Skip Frequency</b>	
	② INSTABILITY FREQUENCY	② SKIP FREQ 1	
	② STABILITY GAIN	② SKIP BAND 1	
		② SKIP FREQ 2	
		② SKIP BAND 2	
		② SKIP FREQ 3	
		② SKIP BAND 3	

**Table 4-1 List of Parameters** Continued

<b>Level 3 Blocks</b>
<b>Profile Run</b>
NUMBER OF CYCLES
PR RESTART MODE
SPEED CURVE 1-7
PROFILE TIME 1-7

- ① Only available or active in Closed Loop Vector mode. Ignore these parameters for Open Loop Vector and V/F modes.
- ② Only available or active in V/F mode. Ignore these parameters for Open Loop Vector mode.
- ③ Only available or active in either Vector mode. Ignore these parameters for V/F mode.

**Table 4-2 Level 1 Parameter Block Definitions**

Block Title	Parameter	Description
PRESET SPEEDS	Preset Speeds #1 - #15	Allows selection of 15 predefined motor operating speeds. Each speed may be selected using external switches connected to terminals at J2. For motor operation, a motor direction command must be given along with a preset speed command.
RAMP RATES	Accel Time #1,2 Decel Time #1,2 Start S-Accel #1,2 End S-Accel #1,2 Start S-Decel #1,2 End S-Decel #1,2	Accel time is the number of seconds required for the motor to increase at a linear rate from "Min Output Speed" to "Max Output Speed" parameter in the Level 2 Output Limits block. Decel time is the number of seconds required for the motor to decrease at a linear rate from "Max Output Speed" parameter to "Min Output Speed". Start S-Curve Acceleration as a percentage of max speed (% 1 and 2) End S-Curve Acceleration as a percentage of max speed (% 1 and 2) Start S-Curve Deceleration as a percentage of max speed (% 1 and 2) End S-Curve Deceleration as a percentage of max speed (% 1 and 2)

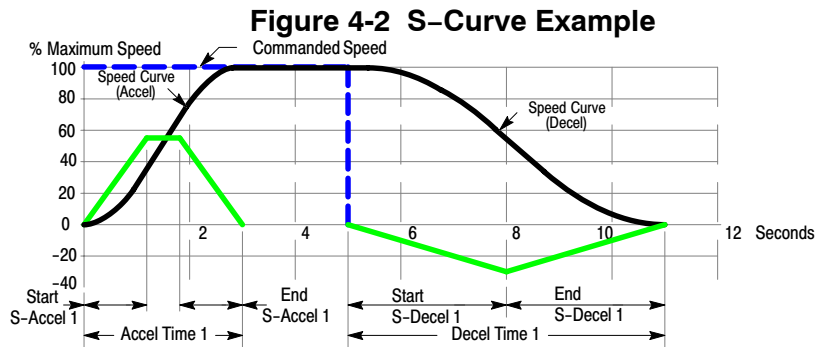

**Table 4-2 Level 1 Parameter Block Definitions - Continued**

Block Title	Parameter	Description
JOG SETTINGS	Jog Speed	Jog Speed is the programmed speed used during jog. Jog can be initiated from the keypad or terminal strip. At the Keypad, press the JOG key then press and hold the direction (FWD or REV). For Standard Run mode, close the JOG input (J2-12) at the terminal strip then close and maintain the direction input (J2-9 or J2-10). Process Control mode operation is different. If the terminal strip Process Mode Enable input (J2-13) is closed, pressing the Keypad JOG key (or closing J2-14) will cause the drive to move in the direction of the error (without pressing FWD or REV).
	Jog Accel Time	Jog Accel Time changes the Accel Time to a new preset value for jog mode.
	Jog Decel Time	Jog Decel Time changes the Decel Time to a new preset value for jog mode.
	Jog Start S-Accel	Start S-Curve Acceleration as a percentage of max speed (% 1 and 2)
	Jog End S-Accel	End S-Curve Acceleration as a percentage of max speed (% 1 and 2)
	Jog Start S-Decel	Start S-Curve Deceleration as a percentage of max speed (% 1 and 2)
	Jog End S-Decel	End S-Curve Deceleration as a percentage of max speed (% 1 and 2)
	Jog Forward	Jogs the motor the drive forward direction at Jog speed.
	Jog Reverse	Jogs the motor the drive reverse direction at Jog speed.

**Table 4-2 Level 1 Parameter Block Definitions - Continued**

Block Title	Parameter	Description
KEYPAD SETUP	Stop Key	OFF Keypad STOP key is not active. ON Allows keypad STOP key to initiate motor stop during remote or serial operation. If active, pressing STOP selects Local mode and initiates the stop command.
	Stop Mode	Selects if the Stop command causes the motor to COAST to a stop or REGEN to a stop. In COAST, the motor is turned off and allowed to coast to a stop. In REGEN, the voltage and frequency to the motor is reduced at a rate set by Decel Time.
	Run Forward	OFF disables FWD key in Local mode. ON makes the keypad FWD key active in Local mode.
	Run Reverse	OFF disables REV key in Local mode. ON makes the keypad REV key active in Local mode.
	Switch on Fly	OFF disables Switch on Fly. ON Allows switching between Local and Remote while Control is on.
	Loc. Hot Start	OFF disables the Stop input at J2-11 in the keypad operating mode. ON enables the Stop input at J2-11 in the keypad operating mode.
	Speed Increment	Sets the increment of speed change for each key press. (1-3600RPM)
	Init Local Speed	At power up, initializes the local speed to 0RPM, the last speed before power down or at Set Speed parameter.
	Set Speed	At power up, initializes the local speed to this preset value if "Init Local Speed" =Set Speed.
	Parameters to Keypad	Transfers the parameter settings stored in the control memory (flash) to keypad memory.
	Keypad to Parameters	Transfers the parameter settings stored in keypad memory to the control memory (flash).
	Keypad Contrast	Sets LCD contrast: 0=dimmiest, 100=brightest.
	Backlight	Turns On/Off the backlight for the keypad display.
(Closed/Open Vector Only)	Local Torque Mode	OFF disables local torque mode. ON enables local torque mode operation.
	Local Torque Ref	Local torque mode reference value.



**Table 4-2 Level 1 Parameter Block Definitions - Continued**

Block Title	Parameter	Description
INPUT SETUP	Operating Mode	Operating Modes are: Keypad, Standard Run 2 and 3 wire, 15SPD, Fan Pump 2 and 3 Wire, Process Mode, 3 SPD ANA 2 and 3 Wire, EPOT 2 and 3 Wire, Bipolar, Network, Profile Run and Mint. External connections to the control are made at the control terminal strip (wiring diagrams are shown in Section 3 "Operating Modes").
	Command Source	Selects the external speed reference to be used. None, Command Source is not used. Analog In1, Connect a 10KΩ pot at J1 or connect a 0-10VDC signal to J1-2 and J1-1. Analog In2, Connect a 0-5V, 0-10V, ±5V, ±10V, 0-20mA or 4-20mA source to J1-4 and 5. 4-20mA should be considered when a long distance (up to 50 ft) between the external device and J1-4 and 5 of the control is necessary. Keypad, Command is from Keypad. Network, Signal source is from a device on the network.
	ANA IN1 TYPE	None, input not used. Potentiometer (0-10V signal is used).
	ANA IN1 INVERT	"OFF" will cause a low input voltage (e.g. 0VDC) to be a low motor speed command and a maximum input voltage (e.g. 10VDC) to be a maximum motor speed command. "ON" will cause a low input voltage (e.g. 0VDC) to be a maximum motor speed command and a maximum input voltage (e.g. 10VDC) to be a low motor speed command.
	ANA IN1 GAIN	Allows 0 to 300% gain to be applied (as in $Y=Gain*(X-Offset)$ ).
	ANA IN1 OFFSET	Provides an offset to the Analog Input to minimize signal drift. For example, if the minimum speed signal is 1VDC (instead of 0VDC) the ANA CMD Offset can be set to -10% so the minimum voltage input is seen by the control as 0VDC. This parameter is automatically adjusted during the auto tune CMD Offset Trim test.
	ANA IN1 FILTER	Amount of signal filtering to use, 0=No filtering, 6= Max filtering. Note: Factory setting is 0. If a different value is chosen, the Level 2 Miscellaneous filter must be off. Do not select both filters at same time.
	ANA IN2 TYPE	Define signal to be used, ±5V, ±10V, 0-20mA or 4-20mA.
	ANA IN2 INVERT	"OFF" will cause a low input voltage (e.g. 0VDC) to be a low motor speed command and a maximum input voltage (e.g. 10VDC) to be a maximum motor speed command. "ON" will cause a low input voltage (e.g. 0VDC) to be a maximum motor speed command and a maximum input voltage (e.g. 10VDC) to be a low motor speed command.
	ANA IN2 GAIN	Allows 0 to 300% gain to be applied (as in $Y=Gain*(X-offset)$ ).
	ANA IN2 OFFSET	Provides an offset to the Analog Input to minimize signal drift. For example, if the minimum speed signal is 1VDC (instead of 0VDC) the ANA CMD Offset can be set to -10% so the minimum voltage input is seen by the control as 0VDC. This parameter is automatically adjusted during the auto tune CMD Offset Trim test.
	ANA IN2 DEADBAND	Allows a defined range of voltage to be a deadband. A command signal within this range will not affect the control output. The deadband value is the voltage above and below the zero command signal level.
	ANA IN2 FILTER	Amount of signal filtering to use, 0=No filtering, 6= Max filtering. Note: Factory setting is 0. If a different value is chosen, the Level 2 Miscellaneous filter must be off. Do not select both filters at same time.
	(Closed/Open Vector Only)	EXT. CURRENT LIMIT
CURRENT LIMIT SOURCE		Selects the external speed reference to be used. None, Command Source is not used. Analog In1, Connect a 10KΩ pot at J1 or connect a 0-10VDC signal to J1-2 and J1-1. Analog In2, Connect a 0-5V, 0-10V, ±5V, ±10V, 0-20mA or 4-20mA source to J1-4 and 5. 4-20mA should be considered when a long distance (up to 50 ft) between the external device and J1-4 and 5 of the control is necessary. Keypad, Command is from Keypad. Network, Signal source is from a device on the network.

**Table 4-2 Level 1 Parameter Block Definitions - Continued**

Block Title	Parameter	Description																																																			
OUTPUT SETUP	Digital Output 1,2	Four digital outputs are available (2 optically isolated and 2 relay). Each output may be configured to any of the following conditions:																																																			
	Relay Output 1,2	<table border="0"> <thead> <tr> <th>Condition</th> <th>Description</th> </tr> </thead> <tbody> <tr> <td>Drive Run -</td> <td>Active when J2-8 is closed.</td> </tr> <tr> <td>Drive Ready -</td> <td>Active when power is applied and no faults are present.</td> </tr> <tr> <td>Drive On -</td> <td>Active when control is "Ready" (has reached excitation level and capable of producing torque).</td> </tr> <tr> <td>Drive Stopped -</td> <td>Active when drive is enabled by stop command issued.</td> </tr> <tr> <td>Jog -</td> <td>Active during Jog mode.</td> </tr> <tr> <td>Accelerate -</td> <td>Active when control is accelerating.</td> </tr> <tr> <td>Constant Speed -</td> <td>Active when control speed is constant.</td> </tr> <tr> <td>Decelerate -</td> <td>Active when control is decelerating.</td> </tr> <tr> <td>At Zero Speed -</td> <td>Active when motor speed is less than the value of the Level 1 Output "Zero SPD Set Pt".</td> </tr> <tr> <td>At Speed -</td> <td>Active when motor speed is within the band set by the Level 1 Output "At Speed Band" parameter (P1506).</td> </tr> <tr> <td>At Set Speed -</td> <td>Active when output speed is at or greater than the Level 1 Output "Set Speed Point" parameter (P1507).</td> </tr> <tr> <td>Current Overload -</td> <td>A normally closed contact that is active (opens) during an Overload fault caused by a time-out when the output current is greater than "Overload Set Point"</td> </tr> <tr> <td>Current Underload -</td> <td>A normally closed contact that is active (opens) during an Underload fault caused by a time-out when the output current is less than "Underload Set Point"</td> </tr> <tr> <td>I<sup>2</sup>T Overload -</td> <td>Active when when in overload.</td> </tr> <tr> <td>Keypad Control -</td> <td>Active when control is in Local keypad control.</td> </tr> <tr> <td>Dynamic Brake -</td> <td>Active when Dynamic Brake transistor is turned ON.</td> </tr> <tr> <td>Foldback -</td> <td>Active when current foldback is active.</td> </tr> <tr> <td>Fault -</td> <td>Active when a fault condition is present (will cause trip).</td> </tr> <tr> <td>Warning -</td> <td>Active when a fault condition is present (but doesn't cause trip).</td> </tr> <tr> <td>Command Forward -</td> <td>Active during forward run command.</td> </tr> <tr> <td>Command Reverse -</td> <td>Active during reverse run command.</td> </tr> <tr> <td>Motor Forward -</td> <td>Active when motor is moving in Drive forward direction.</td> </tr> <tr> <td>Motor Reverse -</td> <td>Active when motor is moving in Drive reverse direction.</td> </tr> <tr> <td>Process Error -</td> <td>Active when process feedback signal is outside the range specified by the Level 2 Process Control block, AT Setpoint Band parameter. Turns off when process feedback error is eliminated.</td> </tr> <tr> <td>Network</td> <td>Active when commanded by network (Modbus). Network device controls this output.</td> </tr> </tbody> </table>	Condition	Description	Drive Run -	Active when J2-8 is closed.	Drive Ready -	Active when power is applied and no faults are present.	Drive On -	Active when control is "Ready" (has reached excitation level and capable of producing torque).	Drive Stopped -	Active when drive is enabled by stop command issued.	Jog -	Active during Jog mode.	Accelerate -	Active when control is accelerating.	Constant Speed -	Active when control speed is constant.	Decelerate -	Active when control is decelerating.	At Zero Speed -	Active when motor speed is less than the value of the Level 1 Output "Zero SPD Set Pt".	At Speed -	Active when motor speed is within the band set by the Level 1 Output "At Speed Band" parameter (P1506).	At Set Speed -	Active when output speed is at or greater than the Level 1 Output "Set Speed Point" parameter (P1507).	Current Overload -	A normally closed contact that is active (opens) during an Overload fault caused by a time-out when the output current is greater than "Overload Set Point"	Current Underload -	A normally closed contact that is active (opens) during an Underload fault caused by a time-out when the output current is less than "Underload Set Point"	I <sup>2</sup> T Overload -	Active when when in overload.	Keypad Control -	Active when control is in Local keypad control.	Dynamic Brake -	Active when Dynamic Brake transistor is turned ON.	Foldback -	Active when current foldback is active.	Fault -	Active when a fault condition is present (will cause trip).	Warning -	Active when a fault condition is present (but doesn't cause trip).	Command Forward -	Active during forward run command.	Command Reverse -	Active during reverse run command.	Motor Forward -	Active when motor is moving in Drive forward direction.	Motor Reverse -	Active when motor is moving in Drive reverse direction.	Process Error -	Active when process feedback signal is outside the range specified by the Level 2 Process Control block, AT Setpoint Band parameter. Turns off when process feedback error is eliminated.	Network
Condition	Description																																																				
Drive Run -	Active when J2-8 is closed.																																																				
Drive Ready -	Active when power is applied and no faults are present.																																																				
Drive On -	Active when control is "Ready" (has reached excitation level and capable of producing torque).																																																				
Drive Stopped -	Active when drive is enabled by stop command issued.																																																				
Jog -	Active during Jog mode.																																																				
Accelerate -	Active when control is accelerating.																																																				
Constant Speed -	Active when control speed is constant.																																																				
Decelerate -	Active when control is decelerating.																																																				
At Zero Speed -	Active when motor speed is less than the value of the Level 1 Output "Zero SPD Set Pt".																																																				
At Speed -	Active when motor speed is within the band set by the Level 1 Output "At Speed Band" parameter (P1506).																																																				
At Set Speed -	Active when output speed is at or greater than the Level 1 Output "Set Speed Point" parameter (P1507).																																																				
Current Overload -	A normally closed contact that is active (opens) during an Overload fault caused by a time-out when the output current is greater than "Overload Set Point"																																																				
Current Underload -	A normally closed contact that is active (opens) during an Underload fault caused by a time-out when the output current is less than "Underload Set Point"																																																				
I <sup>2</sup> T Overload -	Active when when in overload.																																																				
Keypad Control -	Active when control is in Local keypad control.																																																				
Dynamic Brake -	Active when Dynamic Brake transistor is turned ON.																																																				
Foldback -	Active when current foldback is active.																																																				
Fault -	Active when a fault condition is present (will cause trip).																																																				
Warning -	Active when a fault condition is present (but doesn't cause trip).																																																				
Command Forward -	Active during forward run command.																																																				
Command Reverse -	Active during reverse run command.																																																				
Motor Forward -	Active when motor is moving in Drive forward direction.																																																				
Motor Reverse -	Active when motor is moving in Drive reverse direction.																																																				
Process Error -	Active when process feedback signal is outside the range specified by the Level 2 Process Control block, AT Setpoint Band parameter. Turns off when process feedback error is eliminated.																																																				
Network	Active when commanded by network (Modbus). Network device controls this output.																																																				
	Zero SPD Set PT	Sets the speed at which the zero speed opto output becomes active (turns on). When the speed is less than the ZERO SPD SET PT, the opto output becomes active. This is useful when a motor brake is to interlock operation with a motor.																																																			

**Table 4-2 Level 1 Parameter Block Definitions - Continued**

Block Title	Parameter	Description
OUTPUT SETUP Continued	At Speed Band	Sets the speed range in RPM at which the At Speed digital output turns on and remains active within the range. The at speed band serves two digital output conditions, Level 1 Output Setup block At Speed and the Level 2 Protection block Following Error.
	Set Speed Point	Sets the speed that the AT Set Speed digital output becomes active (turns on). When the speed is greater than the Level 1 Output SET SPEED parameter, the digital output becomes active. This is useful when another machine must not start or stop until the motor exceeds a predetermined speed.
	Overload Set Point	Sets the motor current value at which the "Current Overload" digital output is active.
	Underload Set Point	Sets the motor current value at which the "Current Underload" digital output is active.
	Analog Out 1, 2 Signal Source Selection	<p>Speed Ref - Scaled value of the reference speed value.</p> <p>Speed Demand - Scaled value of the Commanded speed value.</p> <p>Acc/Dec - Scaled value of the Acceleration/Deceleration rate.</p> <p>Motor Current - Scaled value of Motor Current.</p> <p>MAG Current - Scaled value of the Motor MAG amps.</p> <p>MAG Current Command - Scaled value of the Motor MAG amps demand.</p> <p>Load Current - Scaled value of the load amps.</p> <p>Load Current Command - Scaled value of the load amps demand.</p> <p>Power - Scaled value of the kW being produced by control.</p> <p>PH1 Current - Scaled value of the phase 1 input current.</p> <p>PH2 Current - Scaled value of the phase 2 input current.</p> <p>PH3 Current - Scaled value of the phase 3 input current.</p> <p>Motor Voltage - Scaled value of the motor voltage.</p> <p>VD Demand - Scaled value of the demand MAG voltage.</p> <p>VQ Demand - Scaled value of the demand load voltage.</p> <p>Bus Voltage - Scaled value of the Bus voltage.</p> <p>ABS Torque - Scaled value of the absolute torque.</p> <p>Torque - Scaled value of the motor torque value.</p> <p>Control Temp - Scaled value of the control heatsink temperature.</p> <p>Analog Input1 - Scaled value of the analog input 1 signal value.</p> <p>Analog Input2 - Scaled value of the analog input 2 signal value.</p> <p>PROC Feedforward - Scaled value of the process feedforward signal.</p> <p>PROC Feedback - Scaled value of the process feedback signal.</p> <p>PROC Setpoint - Scaled value of the process setpoint source.</p> <p>Electric Angle - Scaled value of the electric slip angle.</p> <p>ABS Speed - Scaled value of the absolute motor speed.</p> <p>Velocity - Scaled value of the speed signal.</p> <p>Network - Scaled value of the network speed command.</p> <p>Calibrate - Maximum analog output to calibrate external meter.</p>
	Analog Out 1 Type	Sets the output signal (0-5V, 0-10V, 4-20mA or 0-20mA).
	Analog Out 2 Type	Sets the output signal ( $\pm 5V$ , $\pm 10V$ ).
	Analog Out #1 & 2 Gain	Scale factor for analog output (as in $Y=Gain*X$ ).
	Calibrate Analog Output	Output signal used to calibrate a D/A Converter output signal.

**Table 4-2 Level 1 Parameter Block Definitions - Continued**

Block Title	Parameter	Description
MOTOR CONTROL	(All) Control Type	Sets the control type to V/F Control, Open Vector or Closed Vector. When changed from Closed to Open Vector, the Level 2, Motor Control, Speed Int, Speed Diff and Speed Prop gains may need to be reduced (since open vector performance bandwidths are less than for closed vector).
	(V/Hz Only) Control Base Speed	The speed at which Field Weakening begins.
	(V/Hz Only) Control Base Volt	Voltage that represents base speed.
	(V/Hz Only) Static Boost	Voltage boost for startup.
	(V/Hz Only) Dynamic Boost Cut In	Speed at which dynamic boost begins to take effect.
	(V/Hz Only) Dynamic Boost	The Dynamic Boost parameter can be adjusted to provide more or less running torque from the motor than is available with the factory setting. The boost adjustment alters the output voltage to the motor from the normal voltage value by increasing or decreasing the voltage per frequency unit as defined by the V/Hz profile.
	(V/Hz Only) V/F Efficiency	
	(V/Hz Only) V/F Profile	Sets the Volts/Frequency ratio of the control output (to the motor) for all values of output voltage versus output frequency up to the control base frequency. Because motor voltage is related to motor current, motor voltage can then be related to motor torque. A change in the V/Hz profile can adjust how much torque is available from the motor at various speeds. 3PT profile – allows two linear V/Hz segments by setting the V/Hz 3PT Volts and V/Hz 3PT Frequency parameters. 33%, 67% and 100% Square Law profiles are preset profiles that provide different variations of the squared reduced V/Hz profile. Smooths transitions between static boost and V/Hz curve.
	(V/Hz Only) 3 Point Method	0=Linear, 100=Quadratic
	(V/Hz Only) 3 Point Voltage	The output voltage associated with the 3PT Frequency parameter.
	(V/Hz Only) 3 Point Frequency	The output frequency associated with the 3PT Volts parameter.
	(V/Hz Only) Slip Comp Enable	Compensates for varying load conditions during normal operation.
	(Closed Vector Only)	Feedback Align
Feedback Filter		A larger value provides a more filtered signal but at the cost of reduced bandwidth.
Position Gain		Sets the position loop proportional gain.
(Closed/Open Vector Only) *	Current PROP Gain	Sets the current loop proportional gain.
	Current INT Gain	Sets the current loop integral gain.
	Speed PROP Gain	Sets the speed (velocity) loop proportional gain.
	Speed INT Gain	Sets the speed (velocity) loop integral gain.
	Speed DIFF Gain	Sets the speed (velocity) loop differential gain.
	A.S. Prop Gain	Sets the anti-saturation proportional gain.
	A.S. Integral Gain	Sets the anti-saturation integral gain.
	Motor XM	Sets the Motor magnetizing reactance value.
	Motor R1	Sets the Motor stator resistance value.
	Motor X1	Sets the Motor stator leakage reactance value.
	Motor R2	Sets the Motor rotor resistance value.
	Motor X2	Sets the Motor rotor reactance value.
	Rotor Time Constant	Sets the rotor time constant value.
COMMUNICATION	Baud Rate	Sets the communication baud rate.
	Parity	Sets communication parity.
	Stop Bits	Sets the number of stop bits to use.
	Drive Address	Sets the drive address for communication.
	IP Address	IP address for Ethernet Web Browser Option Board.
	Subnet Mask	Subnet mask for Ethernet Web Browser Option Board.
	Gateway Mask	Gateway mask for Ethernet Web Browser Option Board.
	IP Address Source	IP address source for Ethernet Web Browser Option Board.

\* These values are set during auto tuning. Performance may be affected if the value of these parameters is changed after auto tuning.

**Table 4-3 Level 2 Parameter Block Definitions**

Block Title	Parameter	Description
DRIVE LIMITS	Operating Zone	Sets the PWM operating zone to Standard 2.5kHz or Quiet 8.0kHz output carrier frequency. Two operating modes are available: Constant Torque and Variable Torque. Constant Torque allows 175% for 3 seconds and 150% for 60 seconds of peak overload capacity. Variable Torque allows 115% peak overload for 60 seconds.
	MIN Output Speed	Sets the minimum motor speed in RPM. During operation, the motor speed will not decrease below this value except for motor starts or during dynamic braking to a stop.
	MAX Output Speed	Sets the maximum motor speed in RPM.
	PWM Frequency	The frequency that the output transistors are switched. PWM (pulse width modulation) frequency is also referred to as "Carrier" frequency. PWM should be as low as possible to minimize stress on the output transistors and motor windings. It is recommended that the PWM frequency be set to approximately 15 times the maximum output frequency of the control. Ratios less than 15 will result in non-Sinusoidal current waveforms. Note: Derate output current by 30% for operation between 8.5KHz and 16KHz.
	Peak Current Level	Sets the peak current limit.
	REGEN Torque Limit	Sets the regen current limit.
(Closed/Open Vector Only)	Current Rate Limit	Limits the rate of torque change in response to a torque command.

**Caution: Do not set Level 2, Drive Configure, Power Input parameter to Common Bus if AC power is connected to L1, L2 or L3. Common Bus requires numerous changes, contact Baldor for information.**

Block Title	Parameter	Description
DRIVE CONFIGURE	Speed Units	Sets units to Hz or RPM.
	Factory Settings	Restores factory settings (over writes all stored values).
	Security	Enable security.
	Access Timeout	Sets time limit for login.
	Access Code	Sets security code for login required to access locked parameters.
	Active Parameter Table	Selects parameter table for use (T1, T2, T3 or T4). Note: This parameter is not actually in the Level 2 Blocks. It is Parameter 0052 in the Monitor block if accessing using Mint.
	Clear Fault Log	Deletes all fault log entries.
DRIVE PROTECT	Dead Time Compensation	Enables/Disables PWM Dead Time Compensation.
	Power Input	Three Phase - Allows operation at full rated output current. Single Phase - The output values are derated for single phase operation. The Power base senses the control input power and displays: 3 Phase or Single Phase. The only user selection is Common Bus. Note: For three phase power input, if a phase is lost this parameter will automatically be changed to single phase and the control will automatically be derated for single phase operation. Common bus is selected for special installations that only have DC input power available. It is important not to choose this setting if AC power is connected. Common bus setting disables precharge and soft start features of the control.
	External Trip	OFF - External Trip is Disabled. ON - External Trip is enabled. If a normally closed contact at J2-16 is opened, an External Trip fault will occur and cause the drive to shut down.
	Overload	Sets how the drive handles I <sup>2</sup> T power overloads. When an overload occurs it will either Fault, Foldback, Or Hold.
	Single Phasing (3 phase units only)	Fault - When input power phase is lost for approximately 10 cycles, control trips on fault. Derate - When an input power phase is lost, single phase operation is assumed and control output is derated by 50% and operation is allowed at the reduced output.
	Over Temperature	Fault - When control temperature reaches 85°C, control trips on fault. Derate - When control temperature reaches 80°C (standard or 90°C quiet mode), output is derated by 30% (current limiting) and operation is allowed at the reduced value. Operation at full current is allowed when control temperature decreases to 70°C. If control temperature increases to 85°C, control trips on fault.

**Table 4-3 Level 2 Parameter Block Definitions** Continued

Block Title	Parameter	Description	
DRIVE PROTECT Continued (Closed/Open Vector Only)	Following Error	OFF - Control ignores "At Speed Error" from the process. ON - Control monitors the following error from the process. If the process speed is outside the range set in the Level 1 Output block, AT Speed Band parameter, the drive will fault and will disable.	
	Torque Proving	OFF - Control ignores unbalanced motor phases. ON - Control looks for balanced output current in all three phases to the motor. Unbalanced output current will cause a trip and create a torque proving fault. This occurs only at first drive enable after power up.	
	Encoder Loss	OFF - Encoder loss is ignored. ON - Encoder loss produces a trip condition to disable the drive.	
	Encoder Sense	Automatic - Allows the control to automatically sense encoder direction at power up after a Restore Factory Settings. Manual - Encoder direction is set by Level 1 block, Motor Control, Feedback Align parameter.	
	Foldback Gain Overload Trigger	Sets the slope of the foldback during an I <sup>2</sup> T Overload condition. Sets the trigger point for an overload condition.	
MISCELLAN- EOUS	Auto Restart	<b>Manual</b> Power Up Start - If set to MAN and a run command (enable line & FWD or REV command) is present at power up, the motor will not run. The run command must be removed then reapplied to start operation. The run command refers to the enable plus direction (FWD or REV) lines. Restart after Fault - If a fault occurs during operation, the control must be reset <sup>□</sup> and the run command must be removed then reapplied to start operation. <sup>□</sup> Note: If Restart Fault/Hr. is zero, the control must be manually reset. If Restart Fault/Hr. is non-zero, the control will automatically attempt to reset the fault but will not restart until the run command is removed then reapplied to start operation. <b>Automatic</b> Power Up Start - If set to AUTO and a run command (enable line & FWD or REV command) is present at power up, the control will automatically start. Restart after Fault - If a fault occurs during operation, the control will automatically reset (after the restart delay time) to resume operation if the Fault/Hr is set to a non zero value. 3 Wire modes, AUTO start after a fault or loss of power will not occur because the momentary contacts are open and the run command must again be applied. The run command refers to the enable plus direction (FWD or REV) lines.	
	Restarts/Hr	The maximum number of automatic restart attempts before requiring a manual restart. After one hour without reaching the maximum number of faults or if power is turned off and on again, the fault count is reset to zero.	
	Restart Delay	The amount of time allowed after a fault condition for an automatic restart to occur. Useful to allow sufficient time to clear a fault condition before restart is attempted.	
	PWM Technique	Sets the method used to generate the motor PWM signal, Space Vector or Sine Triangle.	
	Cost of Energy	Sets the billing cost per KWH charged by the local power utility.	
	Reset Energy	Resets the energy counter (in power base of the control).	
	Filter Type	Sets the filter to None, Low pass, High Pass or Notch.	
	Filter Source	Sets the filter source to None, Raw speed, Torque, Analog IN1 or Analog IN2.	
	Filter Destination	Sets the out put of the filter to None, Speed Loop, Torque Loop, Speed Feedforward, Process Feedback, Process Feedforward, or Process Setpoint.	
	Filter Cutoff	Sets the cutoff frequency of the filter.	
	Notch Center Frequency	Sets the center frequency for the notch filter (if Filter Type=Notch).	
	Notch Band	Sets the frequency band of the notch filter (if Filter Type=Notch).	
	(Closed Vector Only)	Homing Speed	This parameter sets the speed that the motor shaft will rotate to a "Home" position when the home input switch is closed. Available only in modes that have a homing (orient) input.
		Homing Offset	This parameter sets the number of quadrature encoder counts past home at which the motor will stop. Quadrature encoder pulses are 4 times the number of encoder lines per revolution. The recommended minimum number is 100 encoder counts to allow for deceleration distance to allow the motor to stop smoothly. Example: Encoder resolution is 1024 lines per revolution. The motor must stop one complete revolution past the home marker position. Therefore: Homing Offset = (1 Revolution) X (4 X 1024 lines per Rev.) = 4096 quadrature counts. Note: Homing direction is always in the drive forward direction.

**Table 4-3 Level 2 Parameter Block Definitions** Continued

Block Title	Parameter	Description
MOTOR DATA	Motor Rated Volt	The rated voltage of the motor (listed on the motor nameplate).
	Motor Rated Amps	The rated current of the motor (listed on the motor nameplate). If the motor current exceeds this value for a period of time, an Overload fault will occur (see Level 2 Output Limits).
	Motor Rated Speed	The rated speed of the motor (listed on the motor nameplate). If Motor Rated SPD = 1750 RPM and Motor Rated Freq = 60 Hz, the Keypad Display will show 1750 RPM at 60 Hz and 875 RPM at 30Hz.
	Motor Rated Frequency	The rated frequency of the motor (listed on the motor nameplate).
	Motor Mag Amps	The motor magnetizing current value (listed on the motor nameplate) also called no load current. Measure using a clamp on amp meter at the AC power line while the motor is running at line frequency with no load connected to the motor shaft.
	Elect Slip Frequency Calculate Motor Model	Sets the rated slip frequency of the motor. NO - No presets are calculated. YES - This procedure loads preset values into memory that are required to perform auto tune. Always run Calculate Motor Model Parameters as the first step of auto tune.
(Closed Vector Only)	Encoder Counts	The number of encoder feedback counts in lines per revolution.
	Encoder Source	Identifies the slot location of the encoder option board.
	Encoder Type	Sets the encoder type to single ended or differential encoder selection.
	Resolver Speed	The speed of the resolver, if a resolver is used for feedback.
(V/Hz Only)	Instability Frequency	Center frequency of the motor instability.
	Stability Gain	Sets the motor stability gain factor.
BRAKE ADJUST	Resistor Ohms	The dynamic braking resistor value in ohms. Refer to dynamic braking manual for additional information.
	Resistor Watts	The dynamic braking resistor watts rating.
	Resistor Thermal Time Constant	Sets the watts per unit time of heat absorption and dissipation for the dynamic braking resistor.
(V/Hz Only)	DC Brake Volts	The amount of DC braking voltage applied to the motor windings during a stop command. Increase this value for more braking torque during stops. The increased braking voltage may cause the motor to overheat for applications that require frequent starts/stops. Be careful in selecting this value. The maximum DC Brake Voltage = (1.414)X(Max Output Volts).
	DC Brake Trigger	The frequency at which dc injection braking will begin.
	Brake On Stop	If set to ON, DC injection braking will begin when a stop command is issued. After a stop command, the DC brake voltage will be applied to the motor windings when the output frequency reaches the DC brake trigger.
	Brake On Reverse	If set to ON, DC injection braking will begin after a change-motor-rotation command is issued. After a stop command, the DC brake voltage will be applied to the motor windings when the output frequency reaches the DC brake trigger. Braking continues until the motor is stopped. The motor will then accelerate in the opposite direction.
	Stop Brake Time	The maximum number of seconds that DC injection brake voltage will be applied to the motor windings after a stop command. After the time specified by this value, DC injection braking is automatically turned off. If DC injection braking starts at a frequency less than the DC brake trigger parameter, the stop brake time is calculated as follows: $\text{Brake Time} = \text{Stop Brake Time} \times \frac{\text{Output Frequency at Braking}}{\text{DC Brake Trigger}}$
	Brake on Start	If set to ON, turns DC injection braking ON for a period of time (Start Brake Time) when a run command is issued. This ensures the motor is not rotating. Braking will automatically turn off and the motor will accelerate at the end of the start brake time.
	Start Brake Time	The amount of time that DC injection braking will be applied after a run command is issued. This will only occur if brake on start is set to ON. Braking may cause the motor to overheat for applications that require frequent starts/stops. Be careful in selecting this value. The start brake time should be just long enough to ensure the motor shaft is not rotating when a start command is issued.
SKIP FREQUENCY (V/Hz Only)	Skip Freq 1, 2, 3	The center frequency of the frequency band to skip or treat as a dead-band. Three bands can be defined independently or the three values can be selected to skip one wide frequency band.
	Skip Band 1, 2, 3	The width of the band centered about the Skip Frequency. For example, if Skip Frequency #1 is set to 20Hz and Skip Band #1 is set to 5Hz, continuous operation is not allowed in the dead-band of 15Hz to 25Hz.

**Table 4-3 Level 2 Parameter Block Definitions** Continued

Block Title	Parameter	Description
SYNCHRO START (V/Hz Only)	Sync Start FWD	Allows the Synchro Start feature to begin scanning motor rotational frequency in the drive forward direction.
	Sync Start REV	Allows the Synchro Start feature to begin scanning motor rotational frequency in the drive reverse direction.
	Start at MAX Frequency	Allows the Synchro Start feature to begin scanning motor rotational frequency at the MAX Frequency or a SET Frequency.
	Sync Scan V/F	Sets the Volts/Hertz ratio for the Synchro Start feature as a percentage of the V/Hz ratio defined by the "Control Base Volts/Control Base Frequency". This Sync Scan V/F percentage value is multiplied by the "Control Base Volts/Control Base Frequency" value. If this value is too high, the inverter may fault on Over-current.
	Sync Setup Time	The time for the inverter to ramp the output voltage from zero to the voltage that corresponds to the Start at MAX Frequency. A 0.5 second delay before the ramp begins is not included in this time. If the Start feature is not operating quickly enough, decrease the Sync Setup Time value.
	Sync Scan Time	The time allowed for Synchro Start to scan and detect rotor frequency. Scanning begins at the Start at MAX Frequency to 0Hz. Generally, the shorter the Sync Scan Time the more likely a false Synchro Start will be detected. This value should be set high enough to eliminate false Synchro Starts.
	Sync Recover Time	The time allowed to ramp up the output voltage from the Synchro Start scan voltage to the normal output voltage. This occurs after the synchronization frequency is detected. This parameter value should be low enough to minimize Synchro Start time without causing the inverter to fault on Over-current.
PROCESS CONTROL	Process Type	Sets the type of PID control. 1 None, 2. Forward Acting. 3. Inverse Acting.
	Process Feedforward	Sets the type of signal used for the process feedforward signal.
	Process Feedback	Sets the type of signal used for the process feedback signal.
	Setpoint Source	Sets the source input signal type to which the process feedback will be compared. If "Setpoint CMD" is selected, the fixed value of the set point is entered in the Setpoint Command parameter value.
	Setpoint Command	Sets the value, as a percentage of the process feedback signal, the control will try to maintain by adjusting motor speed. This is only used when the Setpoint Source is a fixed value "Setpoint CMD" under Setpoint Source.
	Setpoint Band	The operating band within which the Opto or Relay Output is active (turned ON) indicating the process is within the desired range.
	Process PROP Gain	Sets the PID loop proportional gain. This determines how much adjustment to motor speed is made to move the analog input to the setpoint.
	Process INTG Gain	Sets the PID loop Integral gain. Determines how quickly the motor speed is adjusted to correct long term error.
	Process INTG Clamp	Sets the level of the Integrator clamp as a percentage of maximum motor speed.
	Process DIFF Gain	Sets the PID loop differential gain. This determines how much adjustment to motor speed is made for transient error.
	ACC/DEC Adjust	ON - Adjusts the ACC/DEC rate 1 based on process error. OFF - No adjustment is made.
	Error Switch Point	Sets the process error switch point for ACC/DEC profile adjust.
	Process Sleep Band	If process error is less than this value, no PID adjustment is made.
AUTO TUNE	ANA Offset Trim	Measure analog offset for all analog inputs.
	Stator R1 Tune	Measure Stator resistance.
(Open/Closed Vector Only)	One-Step Tuning	Perform one step auto tune.
	Measure Xm (ROT)	Measure MAG Reactance.
	Measure Leakage	Measure leakage reactance and rotor resistance.
	Current Loop Tune	Tune the current controller loop.
	Flux CUR Tune	Tune the flux controller loop.
(Closed Vector Only)	Feedback Test	Check and adjust for feedback alignment.
	Slip Frequency Tune	Tune slip frequency.
	Speed Loop Tune	Tune the speed controller loop.

**Table 4-4 Level 3 Parameter Block Definitions**

Block Title	Parameter	Description
PROFILE RUN	Number of Cycles	Sets the number of cycles that the profile will automatically run before stopping.
	PR Restart Mode	Sets the restart mode if Profile Run is interrupted. 0=Restart, 1=Continue.
	Speed Curve 1-7	Speed for each curve is set by the value of Preset Speed1 (Speed Curve 1) to Preset Speed7 (Speed Curve 7). Sets the speed curve direction for the profile (value is 0-3). 0=FWD-Group1 1=REV-Group1 2=FWD-Group2 3=REV-Group2
	Profile Time 1-7	Sets the time that the profile is allowed to run.



## Section 5 Troubleshooting

The Baldor Control requires very little maintenance and should provide years of trouble free operation when installed and applied correctly. Occasional visual inspection and cleaning should be considered to ensure tight wiring connections and to remove dust, dirt, or foreign debris which can reduce heat dissipation.

Operational failures called "Faults" will be displayed on the keypad display as they occur. A comprehensive list of these faults, their meaning and how to access the fault log and diagnostic information is provided later in this section. Troubleshooting information is provided in table format with corrective actions later in this section.

Before attempting to service this equipment, all input power must be removed from the control to avoid the possibility of electrical shock. The servicing of this equipment should be handled by a qualified electrical service technician experienced in the area of high power electronics.

It is important to familiarize yourself with the following information before attempting any troubleshooting or service of the control. Most troubleshooting can be performed using only a digital voltmeter having at least 1 meg Ohm input impedance. In some cases, an oscilloscope with 5 MHz minimum bandwidth may be useful. Before contacting Baldor, check that all power and control wiring is correct and installed according to the recommendations in this manual.

### Event Log

From the Menu display screen, select Event Log and press enter.

If an error is displayed during operation, press the "Help" key to learn more about the error. If more than one error was logged, access the Event Log and examine each error Entry at the time of the event to learn more about the error. Only events that occurred approximately at the time of the event need to be checked. Older events are probably not related.

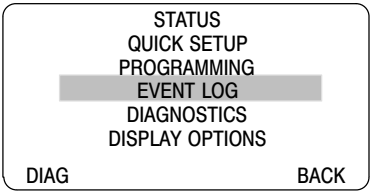
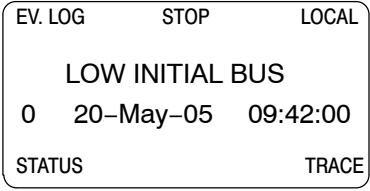
Action	Description	Display	Comments
Status Display	After power-up the display shows the Status screen.	 <p>STATUS      FWD      LOCAL</p> <p>159.5V      600RPM</p> <p>6.2A      20.00HZ</p> <p>DIAG      600r      MAIN</p>	
Press Menu	Displays top level menu options.	 <p>STATUS</p> <p>QUICK SETUP</p> <p>PROGRAMMING</p> <p>EVENT LOG</p> <p>DIAGNOSTICS</p> <p>DISPLAY OPTIONS</p> <p>DIAG      BACK</p>	<p>Press ▲ or ▼ to move cursor over the "EVENT LOG" selection.</p> <p>Press Enter to view the event log.</p>
Event Log Display	<p>Displays error name, Entry # and time the error occurred.</p> <p>LOW INITIAL BUS</p> <p>0      Date      Time</p> <p>Entry #      DD/MM/YY      HH:MM</p> <p>0-9</p>	 <p>EV. LOG      STOP      LOCAL</p> <p>LOW INITIAL BUS</p> <p>0      20-May-05      09:42:00</p> <p>STATUS      TRACE</p>	<p>Press ▲ or ▼ to view next entry.</p> <p>Press R to display Trace menu.</p> <p>Press A to return to Status Menu.</p>

**Trace**

Trace is used to display control conditions present at the time the fault occurred. Input states, Output states, various voltage and current values etc. can be viewed to help understand the cause of the fault condition. Each event in the Event log has its own trace displays that were captured when that event occurred. Scroll through the event log to the event you wish to investigate.

Action	Description	Display	Comments
Event Log Display	Displays error name, Entry # and time the error occurred. LOW INITIAL BUS 0 Date Time Entry # DD/MM/YY HH:MM 0-9	<pre> EV. LOG      STOP      LOCAL           LOW INITIAL BUS           0  20-May-05  09:42:00           STATUS              TRACE           </pre>	Press ▲ or ▼ to view next entry. Press R to display Trace menu. Press A to return to Status Menu.

**Trace Displays**

Action	Description	Display	Comments
Event Log Display	Press ▲ or ▼ to scroll to the event you want to investigate.	<pre> EV. LOG      STOP      LOCAL           LOW INITIAL BUS           3  20-May-05  09:42:00           STATUS              TRACE           </pre>	Press R (or press Enter) to show the Trace menu for the event.
Event Trace Display	FPGA is a <b>Field Programmable Gate Array</b> chip located in the power base electronics. It communicates with the control microprocessor and this is one of it's error words.	<pre> EV. LOG      FAULT TRACE           FPGA FAULT           0x0000           STATUS      T0003      BACK           </pre>	Press ▲ or ▼ to view next entry. This is a hex value. The T0003 indicates we are viewing the trace for event 3 of the event log.

**FPGA FAULT Word Interpretation**

FPGA Fault Display		Description
Hexadecimal	Binary	
0000	0000000000000000	No Fault
0001	0000000000000001	Motor Phase U upper Transistor
0002	0000000000000010	Motor Phase U lower Transistor
0004	0000000000000100	Motor Phase V lower Transistor
0008	0000000000001000	Motor Phase V upper Transistor
0010	0000000000100000	Motor Phase W lower Transistor
0020	0000000001000000	Motor Phase W upper Transistor
0040	0000000010000000	Brake Desaturation Fault
0080	0000000100000000	Brake igbt fault
0100	0000000100000000	Line Loss (AC Power)
0200	0000001000000000	Line Sag (AC Power)
0400	0000010000000000	Ground Fault
0800	0000100000000000	Over Current Fault (Active Low)
1000	0001000000000000	Pulse by Pulse fault on Motor Phase 1
2000	0010000000000000	Pulse by Pulse fault on Motor Phase 2
4000	0100000000000000	Pulse by Pulse fault on Motor Phase 3
8000	1000000000000000	Inverter Desaturation Fault

**Trace Displays** Continued

Action	Description	Display	Comments
Event Trace Display	Second word in the event trace is the FPGA Alarm Word. The T0003 indicates we are viewing the trace for event 3 of the event log.	<div style="border: 1px solid black; padding: 5px; width: fit-content; margin: auto;"> <div style="display: flex; justify-content: space-between; font-size: small;"> <span>EV. LOG</span> <span>FAULT TRACE</span> </div> <div style="text-align: center; margin: 10px 0;"> <p><b>FPGA ALARM</b> 0x0000</p> </div> <div style="display: flex; justify-content: space-between; font-size: small;"> <span>STATUS</span> <span>T0003</span> <span>BACK</span> </div> </div>	<p>Press ▲ or ▼ to view next entry.</p> <p>This is a hex value.</p>

FPGA ALARM Word Interpretation

FPGA Fault Display		Description
Hexadecimal	Binary	
0000	0000000000000000	No Alarm
0001	0000000000000001	Fan Alarm
0002	0000000000000010	Motor Over Temperature
0004	0000000000000100	Phase Loss
0008	0000000000001000	Line Loss
0010	0000000000010000	Line Sag
0020	0000000000100000	Not Used
0040	0000000001000000	Not Used
0080	0000000010000000	Not Used
0100	0000000100000000	Not Used
0200	0000001000000000	Not Used
0400	0000010000000000	Not Used
0800	0000100000000000	Not Used
1000	0001000000000000	Not Used
2000	0010000000000000	Not Used
4000	0100000000000000	Not Used
8000	1000000000000000	Not Used

Action	Description	Display	Comments
Event Trace Display	Third word in the event trace is the Voltage reference for the Analog to Digital Converter.	<div style="border: 1px solid black; padding: 5px; width: fit-content; margin: auto;"> <div style="display: flex; justify-content: space-between; font-size: small;"> <span>EV. LOG</span> <span>FAULT TRACE</span> </div> <div style="text-align: center; margin: 10px 0;"> <p><b>ADC CURRENT REF</b> 0.000 V</p> </div> <div style="display: flex; justify-content: space-between; font-size: small;"> <span>STATUS</span> <span>T0003</span> <span>BACK</span> </div> </div>	<p>Press ▲ or ▼ to view next entry.</p>
Event Trace Display	Next is the Voltage measurement of the Internal 24V power supply for the Opto Inputs and Outputs.	<div style="border: 1px solid black; padding: 5px; width: fit-content; margin: auto;"> <div style="display: flex; justify-content: space-between; font-size: small;"> <span>EV. LOG</span> <span>FAULT TRACE</span> </div> <div style="text-align: center; margin: 10px 0;"> <p><b>24 V REF</b> 0.0 V</p> </div> <div style="display: flex; justify-content: space-between; font-size: small;"> <span>STATUS</span> <span>T0003</span> <span>BACK</span> </div> </div>	<p>Press ▲ or ▼ to view next entry.</p>
Event Trace Display	Next is the status of the nine Digital Input signals. J2-8 (Enable) is the left most digit. J2-16 (DIN#8) is the right most digit).	<div style="border: 1px solid black; padding: 5px; width: fit-content; margin: auto;"> <div style="display: flex; justify-content: space-between; font-size: small;"> <span>EV. LOG</span> <span>FAULT TRACE</span> </div> <div style="text-align: center; margin: 10px 0;"> <p><b>USER INPUTS</b> 00000000</p> </div> <div style="display: flex; justify-content: space-between; font-size: small;"> <span>STATUS</span> <span>T0003</span> <span>BACK</span> </div> </div>	<p>Press ▲ or ▼ to view next entry.</p> <p>This is a bit display, not a hex value.</p>

**Trace Displays** Continued

Action	Description	Display	Comments
Event Trace Display	Next is the status of the Digital Output signals.	<div style="border: 1px solid black; padding: 5px; text-align: center;"> EV. LOG                      FAULT TRACE   DIGITAL OUTPUTS  00000000   STATUS              T0003              BACK </div>	Press ▲ or ▼ to view next entry.  This is a bit display, not a hex value.

Digital Outputs Display		Description
Hexadecimal	Binary	
00	00000000	No Fault
80	10000000	Digital Output 1 (J2-17,18) active
40	01000000	Digital Output 2 (J2-19,20) active
20	00100000	Relay Output 1 (J3-25, 26, 27) active
10	00010000	Relay Output 2 (J3-28, 29, 30) active
08	00001000	Soft start (pre-charge) relay active
04	00000100	Dynamic Brake active
02	00000010	Main SCR enable (active low)
01	00000001	Actual Speed is less than Zero Speed Band

Action	Description	Display	Comments
Event Trace Display	Next is the voltage present at Analog Input 1.	<div style="border: 1px solid black; padding: 5px; text-align: center;"> EV. LOG                      FAULT TRACE   ANA INPUT 1  0.0 V   STATUS              T0003              BACK </div>	Press ▲ or ▼ to view next entry.
Event Trace Display	Next is the voltage present at Analog Input 2.	<div style="border: 1px solid black; padding: 5px; text-align: center;"> EV. LOG                      FAULT TRACE   ANA INPUT 2  0.0 V   STATUS              T0003              BACK </div>	Press ▲ or ▼ to view next entry.
Event Trace Display	Next is the Speed Reference Setting.	<div style="border: 1px solid black; padding: 5px; text-align: center;"> EV. LOG                      FAULT TRACE   SPEED REF  0 RPM   STATUS              T0003              BACK </div>	Press ▲ or ▼ to view next entry.

**Trace Displays** Continued

Action	Description	Display	Comments
Event Trace Display	Next is the AC output current on phase 1.	<div style="border: 1px solid black; padding: 5px;"> <p style="text-align: center;">EV. LOG                      FAULT TRACE</p> <p style="text-align: center;">PH1 CURRENT 0.0 A</p> <p style="text-align: center;">STATUS            T0003            BACK</p> </div>	Press ▲ or ▼ to view next entry.
Event Trace Display	Next is the AC output current on phase 2.	<div style="border: 1px solid black; padding: 5px;"> <p style="text-align: center;">EV. LOG                      FAULT TRACE</p> <p style="text-align: center;">PH2 CURRENT 0.0 A</p> <p style="text-align: center;">STATUS            T0003            BACK</p> </div>	Press ▲ or ▼ to view next entry.
Event Trace Display	Next is the AC output current on phase 3.	<div style="border: 1px solid black; padding: 5px;"> <p style="text-align: center;">EV. LOG                      FAULT TRACE</p> <p style="text-align: center;">PH3 CURRENT 0.0 A</p> <p style="text-align: center;">STATUS            T0003            BACK</p> </div>	Press ▲ or ▼ to view next entry.
Event Trace Display	Next is the Motor Current.	<div style="border: 1px solid black; padding: 5px;"> <p style="text-align: center;">EV. LOG                      FAULT TRACE</p> <p style="text-align: center;">MOTOR CURRENT 0.0A</p> <p style="text-align: center;">STATUS            T0003            BACK</p> </div>	Press ▲ or ▼ to view next entry.
Event Trace Display	Next is the Motor Torque.	<div style="border: 1px solid black; padding: 5px;"> <p style="text-align: center;">EV. LOG                      FAULT TRACE</p> <p style="text-align: center;">MOTOR TORQUE 0.0 NM</p> <p style="text-align: center;">STATUS            T0003            BACK</p> </div>	Press ▲ or ▼ to view next entry.
Event Trace Display	Next is the Motor Voltage.	<div style="border: 1px solid black; padding: 5px;"> <p style="text-align: center;">EV. LOG                      FAULT TRACE</p> <p style="text-align: center;">MOTOR VOLTS 0.0V</p> <p style="text-align: center;">STATUS            T0003            BACK</p> </div>	Press ▲ or ▼ to view next entry.
Event Trace Display	Next is the Motor Speed.	<div style="border: 1px solid black; padding: 5px;"> <p style="text-align: center;">EV. LOG                      FAULT TRACE</p> <p style="text-align: center;">MOTOR SPEED 0 RPM</p> <p style="text-align: center;">STATUS            T0003            BACK</p> </div>	Press ▲ or ▼ to view next entry.

**Trace Displays** Continued

Action	Description	Display	Comments
Event Trace Display	Next is Bus Voltage.	<pre> EV. LOG          FAULT TRACE                 BUS VOLTAGE                 0.0 V STATUS    T0003    BACK                     </pre>	Press ▲ or ▼ to view next entry.
Event Trace Display	Last is the temperature of the control heatsink.	<pre> EV. LOG          FAULT TRACE                 DRIVE TEMP                 0.0 °C STATUS    T0003    BACK                     </pre>	Press ▲ or ▼ to view next entry.
Event Trace Display		<pre> EV. LOG                 END OF                 FAULT TRACE STATUS                    BACK                     </pre>	Press Enter or R to return to the event log.

**Diagnostics Information**

After power up, select the Diagnostic Menu to see information from the diagnostic displays.

Action	Description	Display	Comments
Press Menu	Displays top level menu options.	<pre>                 STATUS                 QUICK SETUP                 PROGRAMMING                 EVENT LOG                 DIAGNOSTICS                 DISPLAY OPTIONS STATUS                    BACK                     </pre>	Press ▲ or ▼ to move cursor over the "DIAGNOSTICS" selection. Press Enter to view diagnostic information.
Diagnostic Display	Displays software version, hp, volts and Amp/Volt ratings.	<pre> DIAG          STOP          LOCAL                 ZHH-1.XX RATED HP                3HP RATED VOLTS            240.0V RATED A/V              4.0A/V EV. LOG          0r          MAIN                     </pre>	Press ► or ◀ to go to the next or previous Diagnostic screen. Press R to return to previous menu.
Press ► to display next group.		<pre> DIAG          STOP          LOCAL                 ZHH-1.XX RATED CURRE            9.6A RATED PK CU           16.8A EV. LOG          0r          MAIN                     </pre>	Press ► or ◀ to go to the next or previous Diagnostic screen. Press R to return to previous menu.

**Diagnostics** Continued

Action	Description	Display	Comments
Press ► to display next group.	Displays real time clock values (date and time) and total run time since installation.  Press ENTER to set date and time.	<pre> DIAG      STOP      LOCAL       REAL TIME CLOCK       May 20, 2005       22:7:35 RUN TIMER          474.1HR EV. LOG           0r      MAIN           </pre>	Press ► or ◀ to go to the next or previous Diagnostic screen.  Press R to return to previous menu.
Press ► to display next group.	Displays energy cost (based on parameter # 2305 value).	<pre> DIAG      STOP      LOCAL       ENERGY EST POWER          0.00KW EST ENERGY        0.0KWH EST COST            0.0\$ EV. LOG           0r      MAIN           </pre>	Press ► or ◀ to go to the next or previous Diagnostic screen.  Press R to return to previous menu.  Press A to go to Status screen.
Press ► to display next group.	Diagnostic Analog Input values display.	<pre> DIAG      STOP      LOCAL       ANALOG INPUTS ANA IN1              1.3v ANA IN2              0.0v EV. LOG           0r      MAIN           </pre>	Press ► or ◀ to go to the next or previous Diagnostic screen.  Press R to return to previous menu.
Press ► to display next group.	Diagnostic Analog Output values display.	<pre> DIAG      STOP      LOCAL       ANALOG OUTPUTS ANA OUT1             0.0V ANA OUT2             0.0V EV. LOG           0r      MAIN           </pre>	Press ► or ◀ to go to the next or previous Diagnostic screen.  Press R to return to previous menu.
Press ► to display next group.		<pre> DIAG      STOP      LOCAL       POSITION COUNTER REVOLUTIONS          0 COUNTS              0CNT EV. LOG           0r      MAIN           </pre>	Press ► or ◀ to go to the next or previous Diagnostic screen.  Press R to return to previous menu.
Press ► to display next group.	Diagnostic installed Option Card identification display.	<pre> DIAG      STOP      LOCAL       OPTION BOARDS OPTION 1              NONE OPTION 2              NONE FEEDBACK              ENCODER EV. LOG           0r      MAIN           </pre>	Press ► or ◀ to go to the next or previous Diagnostic screen.  Press R to return to previous menu.  Press A to go to Status screen.
Press ► to display next group.	Displays keypad software version.	<pre> DIAG      STOP      LOCAL       KEYPAD VERSION KEYPAD SOF           1.XX 03/0 EV. LOG           0r      MAIN           </pre>	
Press ► to display next group.		<pre> DIAG      STOP      LOCAL       POWER BASE BUS VOLTAGE           333.9V DRIVE TEMP            26.1C OVERLOAD LE           100.0% EV. LOG           0r      MAIN           </pre>	Press ► or ◀ to go to the next or previous Diagnostic screen.  Press R to return to previous menu.

## Diagnosics Continued

Action	Description	Display	Comments
Press ► to display next group.	Displays active operating mode settings.	<pre> DIAG      STOP      LOCAL OPERATING MODE   Keypad   Speed   Closed Vector EV. LOG      or      MAIN           </pre>	
Press ► to display next group.	Bit display of digital inputs, outputs and the voltage present at the internal 24V supply terminals.	<pre> DIAG      STOP      LOCAL DIGITAL I/O INPUTS                000000000 OUTPUTS                0110 USER 24V              24.9V EV. LOG      or      MAIN           </pre>	Press ► or ◀ to go to the next or previous Diagnostic screen. Press R to return to previous menu.
Press ► to display next group.	Note: This screen does not appear if Level 2 Process Control, Process type is set to None.	<pre> DIAG      STOP      LOCAL PROC CONTROL PID   0.00HZ              0.0FF   0.0SP               0.0FB EV. LOG      or      MAIN           </pre>	Press ► or ◀ to go to the next or previous Diagnostic screen. Press R to return to previous menu.

## Fault Messages

**Table 5-1 Fault Messages**

Type	Fault Message Display	Description
F	No fault exists	Control is operating properly, no faults recorded.
F	Unknown system fault	Reset the control. Restore parameter values to factory settings.
F	Configuration fault	Reset the control. Restore parameter values to factory settings.
F	Comms timeout	Communications failure between control board and power board. Check ribbon cable and connections.
F	Parameter checksum	Reset the control. Restore parameter values to factory settings.
F	New power base ID	Changing the Power Base, Control board, or new firmware will most often cause this error. Reset the control. Restore parameter values to factory settings.
F	Surge current	Motor current exceeded peak limit. Check: motor connections, motor load, increase accel/decel times.
F	Desaturation	Output current exceeds desat limit. Check: motor for short circuit, motor load, increase accel/decel times.
F	Ground fault	Ground Fault detected (output current leakage to ground). Disconnect motor, check motor for insulation leakage to ground.
F	Logic power supply fault	Logic power supply failure detected.
F	Power Base Fault	Usually occurs with other faults. Fault detected in power base, see FPGA in event log trace.
F	Low Initial BUS	Bus volt less than 200/400/500V on 230V/460V/575V units at power up. Check: line volt, resistors on R1/ R2.
F	Current Sense Fault	Occurs on power up, motor current sensor(s) out of tolerance.
F	User reference voltage	Internal reference power supply out of tolerance.
F	User 24 volt supply	24V at J1-23 and J1-24 out of spec. Check 24V, if below, remove wiring from terminal strip, re-check.
F	Current reference	Reference volt for current readings out of tolerance.
F	I <sup>2</sup> T long term (one minute) overload	Peak output current exceeded the 1 minute rating value. Check motor and wires, Level 2 Pk CUR Limit value, Accel time or reduce motor load. Change Level 2 Drive Protect, Overload to "Foldback" and try again.
F	I <sup>2</sup> T short term (three second) overload	Peak output current exceeded the 3 second rating value. Check motor and wires, Level 2 Pk CUR Limit value, Accel time or reduce motor load. Change Level 2 Drive Protect, Overload to "Foldback" and try again.
F	Following Error	Speed error beyond Set Speed Band parameter value. Verify motor is not overloaded.
F	DC Bus over voltage	DC Bus V over 405/810/1000V for 230V/460V/575V units. Check line volt, decel rates, resistor on R1/ R2.
F	DC Bus under voltage	DC Bus V below 220/440/550V for 230V/460V/575V units. Check line volt, B+ to B- voltage.
F	Drive Over TEMP	Heatsink temp exceeded 85/95C. Verify ambient does not exceed 45C. Clean fans and heatsink.
F	External trip - standard	TH1 or TH2 is open.
F	External trip - terminal strip	Connection at J2-16 is open.
F	Torque Proving	Failed to measure current in one or more motor phases. Check motor connections or open motor contacts.
F	Regen R or PWR	Excessive resistor power dissipation. Check resistor ratings, extend decel times, or add larger braking kit.

F = Fault, A = Alarm



**Fault Messages** Continued

**Table 5-1 Fault Messages** Continued

Type	Fault Message Display	Description
F	EEPROM fault	EE memory. Reset the control. Restore parameter values to factory settings.
F	Software version	Unused fault code.
F	Line regen fault	Unused fault code.
F	Internal Config	Software boot error. Reset the control. Restore parameter values to factory settings.
F	Dyn Brake Desat	Dynamic braking current limit exceeded. Check for shorted braking resistor circuit.
A	Line Loss	All 3 input phases lost. Check input circuit breaker, fuses or input contacts.
A	Phase Loss	One input phase lost. Check input circuit breaker, fuses or input contacts.
F	U Upper Fault	Power transistor fault on T1.
F	U Lower Fault	Power transistor fault on T1.
F	V Upper Fault	Power transistor fault on T2.
F	V Lower Fault	Power transistor fault on T2.
F	W upper fault	Power transistor fault on T3.
F	W lower fault	Power transistor fault on T3.
F	Phase 1 pulse by pulse fault	Phase 1 (T1) curr limiting via pulse by pulse method; check motor: spiking loads, chattering contacts.
F	Phase 2 pulse by pulse fault	Phase 2 (T2) curr limiting via pulse by pulse method; check motor: spiking loads, chattering contacts.
F	Phase 3 pulse by pulse fault	Phase 3 (T3) curr limiting via pulse by pulse method; check motor: spiking loads, chattering contacts.
F	Forced network fault	Forced network fault. Possible reason: watchdog, timing, user control.
F	Memory failure	Option card problem, memory failure.
A	Aux Filter Setup	Option card problem, card not supported or not recognized. Check: drive firmware version.
F	Power Base FPGA	Filter Source should be set to Raw Speed when destination is set to Speed Loop.
A	Sel Enc Source	Encoder Source Not Selected/Feedback Board is absent. Choose the appropriate card for encoder feedback.
F	Download	Parameter download from keypad or network has failed. Verify parameter set compatibility.
F	Parameter	Parameters momentarily locked. Wait 30 seconds, try again
A	Invalid Enc Sel	Feedback board not installed on this slot. Select an encoder feedback board as encoder source.
F	ADC Calib Fault	ADC calibration voltages out of range. Check analog input wiring
F	Encoder Loss	Encoder detected but has poor or no signal. Check encoder wiring.
F	Over Speed	Rotor speed over 110% maximum speed limit.
F	DC Bus Short	For UL testing only. Call Baldor for service.
A	Motor Overtemp	Motor has overheated, check: cooling system or blocked air flow.
A	Fan Loss	Fan circuit is seeing low current or over current. Check fan circuit.
F	DC PK Overvolt	Bus peak voltage rating exceeded. Check: AC input lines; sizing of dynamic brake.
A	Line Sag	All 3 phase input lines have sagged below 70% of nominal. Check input line quality
F	Brake Desat	Dynamic brake de-saturation has occurred. Check dynamic brake circuit.
A	Drive Disabled	Motion command given with drive disabled. Check: drive enable input.
A	Drive Enabled	Drive enabled during parameter download. Drive must be disabled.

F = Fault, A = Alarm

**Electrical Noise Considerations**

All electronic devices are vulnerable to significant electronic interference signals (commonly called “Electrical Noise”). At the lowest level, noise can cause intermittent operating errors or faults. From a circuit standpoint, 5 or 10 millivolts of noise may cause detrimental operation. For example, analog speed and torque inputs are often scaled at 5 to 10VDC maximum with a typical resolution of one part in 1,000. Thus, noise of only 5 mV represents a substantial error.

At the extreme level, significant noise can cause damage to the drive. Therefore, it is advisable to prevent noise generation and to follow wiring practices that prevent noise generated by other devices from reaching sensitive circuits. In a control, such circuits include inputs for speed, torque, control logic, and speed and position feedback, plus outputs to some indicators and computers.

---

## Relay and Contactor Coils

Among the most common sources of noise are the coils of contactors and relays. When these highly inductive coil circuits are opened, transient conditions often generate spikes of several hundred volts in the control circuit. These spikes can induce several volts of noise in an adjacent wire that runs parallel to a control-circuit wire. Figure 5-1 illustrates noise suppression for AC and DC relay coils.

**Figure 5-1 AC and DC Coil Noise Suppression**

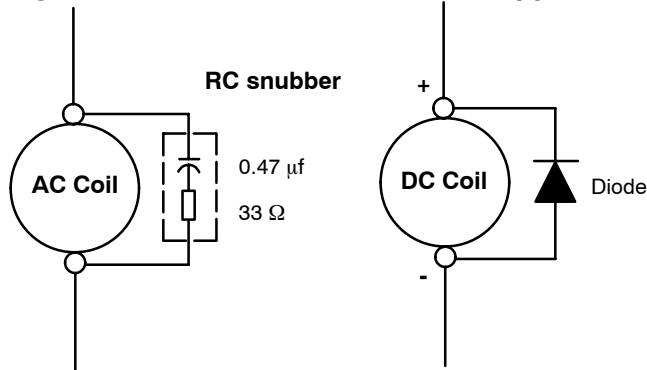

## Wires between Controls and Motors

Output leads from a typical 460VAC drive controller contain rapid voltage rises created by power semiconductors switching 650V in less than a microsecond, 1,000 to 10,000 times a second. These noise signals can couple into sensitive drive circuits. If shielded pair cable is used, the coupling is reduced by nearly 90%, compared to unshielded cable.

Even input AC power lines contain noise and can induce noise in adjacent wires. In some cases, line reactors may be required.

To prevent induced transient noise in signal wires, all motor leads and AC power lines should be contained in rigid metal conduit, or flexible conduit. Do not place line conductors and load conductors in same conduit. Use one conduit for 3 phase input wires and another conduit for the motor leads. The conduits should be grounded to form a shield to contain the electrical noise within the conduit path. Signal wires - even ones in shielded cable should never be placed in the conduit with motor power wires.

## Special Drive Situations

For severe noise situations, it may be necessary to reduce transient voltages in the wires to the motor by adding load reactors. Load reactors are installed between the control and motor.

Line and Load Reactors are typically 3% reactance and are designed for the frequencies encountered in PWM drives. For maximum benefit, the reactors should be mounted in the drive enclosure with short leads between the control and the reactors.

## Control Enclosures

Motor controls mounted in a grounded enclosure should also be connected to earth ground with a separate conductor to ensure best ground connection. Often grounding the control to the grounded metallic enclosure is not sufficient. Usually painted surfaces and seals prevent solid metallic contact between the control and the panel enclosure. Likewise, conduit should never be used as a ground conductor for motor power wires or signal conductors.

## Special Motor Considerations

Motor frames must also be grounded. As with control enclosures, motors must be grounded directly to the control and plant ground with as short a ground wire as possible. Capacitive coupling within the motor windings produces transient voltages between the motor frame and ground. The severity of these voltages increases with the length of the ground wire. Installations with the motor and control mounted on a common frame, and with heavy ground wires less than 10 ft. long, rarely have a problem caused by these motor-generated transient voltages.

## Analog Signal Wires

Analog signals generally originate from speed and torque controls, plus DC tachometers and process controllers. Reliability is often improved by the following noise reduction techniques:

- Use twisted-pair shielded wires with the shield grounded at the drive end only.
- Route analog signal wires away from power or control wires (all other wiring types).
- Cross power and control wires at right angles (90°) to minimize inductive noise coupling.

## Section 6

# Manual Tuning the Series H2 Control

---

**Manually Tuning the Control** In some applications the drive cannot be accurately auto tuned in an application. In these cases, it is necessary to calculate the values needed to tune the drive and manually enter these calculated parameter values.

**Motor Mag Amps Parameter** This parameter is located in the Level 2, Motor Data Block. This parameter is normally entered using the nameplate data (motor no load amps) or auto tuned. If no other data is available, set Motor Mag Amps parameter to about 40% of the motor rated current stated on the nameplate.

The following procedure should be used for setting the Motor Mag Amps parameter with the motor coupled to the load:

1. Adjust the Motor Mag Amps parameter to 40% of the motor nameplate full load current rating.
2. Give the controller a speed command input of 80% of the Base Speed on motor nameplate.
3. Observe the Motor Rated Volt parameter on the keypad Diagnostic display. Ideally, it should be 80% of motor nameplate voltage. By raising the Motor Mag Amps parameter value, the motor voltage will increase proportionally. By reducing the Motor Mag Amps parameter value, the motor voltage will decrease proportionally.
4. While the motor is running, adjust the Motor Mag Amps parameter until the display indicates the proper voltage (80% of motor rated).

**Electrical Slip Frequency Parameter** This parameter is located in the Level 1, Motor Control Block. The slip frequency may be calculated from nameplate data or auto tuned.

$$F_{\text{slip}} = \text{Rated Freq} - \left[ \frac{(\text{Rated RPM} \times \text{Number of Motor Poles})}{120} \right]$$

**Current Prop Gain Parameter** This parameter is located in the Level 1, Motor Control Block. The value is set at the factory and must only be changed with Auto Tune. Do not attempt to change the value manually.

### Current Int Gain Parameter

The Current Int Gain parameter located in the Level 1 Motor Control Block is factory set at 150 Hz. This setting is suitable for most applications.

### Speed Prop Gain Parameter

The Speed Prop Gain parameter located in the Level 1 Motor Control Block is factory set to 10. This gain may be increased or decreased to suit the application. Increasing the Speed Prop Gain parameter will result in faster response, excessive proportional gain will cause overshoot and ringing. Decreasing the Speed Prop Gain parameter will cause slower response and decrease overshoot and ringing.

---

## Speed Int Gain Parameter

The Speed Int Gain parameter in the Level 1 Motor Control Block is set to 10 Hz and may be set at any value. See also, PI Controller later in this section.

Setting the Speed Int Gain parameter to 0Hz removes integral compensation that results in a proportional rate loop. This selection is for systems where overshoot must be avoided and stiffness (ability of the controller to maintain commanded speed with varying torque loads) isn't required.

Increasing values of the Speed Int Gain parameter increases the stiffness of the controller. Typical setting is 4 Hz. If the Speed Prop Gain parameter and the Speed Int Gain parameter are set too high, an overshoot condition can occur.

To manually tune the control, the following procedure is used:

1. Set the speed Integral Gain parameter = 0 (remove integral gain).
2. Increase the Speed Prop Gain parameter setting until adequate response to step speed commands is attained.
3. Increase the Speed Integral Gain parameter setting to increase the stiffness of the drive.

Note: It is convenient to monitor speed step response with a strip chart recorder or storage oscilloscope connected to J1A-6 or -7 with Level 1, Output Block Analog Out #1 or #2 set to ABS SPEED, 0 VDC = zero speed. See Section 3 for a discussion of analog outputs.

## PI Controller

Both the current and rate control loops are of the Proportional plus Integral type. If "E" is defined to be the error signal,

$E = \text{Command} - \text{Feedback}$

then the PI controller operated on "E" as

$$\text{Output} = (K_p * E) + (K_i \int E dt)$$

where  $K_p$  is the proportional gain of the system and  $K_i$  is the integral gain of the system.

The transfer function (output /E) of the controller using 1/s (Laplace Operator) to denote the integral,

$$\text{Output}/E = K_p + K_i / s = K_p (s + K_i/K_p) / s.$$

The second equation shows that the ratio of  $K_i/K_p$  is a frequency in radians/sec. In the Baldor AC Vector Control, the integral gain has been redefined to be,

$$K_i = (K_i / K_p) / (2\pi) \text{ Hz},$$

and the transfer function is,

$$\text{Output}/E = K_p (s + 2\pi K_i) / s.$$

The integral gain is a frequency (in Hz) and should be set to about 1/10 of the bandwidth of the control loop.

The proportional gain sets the open loop gain of the system, the bandwidth (speed of response) of the system. If the system electrical noise is excessive, the most likely cause is that the proportional gain is set too high.

## Section 7 Specifications, Ratings & Dimensions

### Specifications:

<b>Input Ratings</b>	Voltage	180–264VAC 340–528VAC 515–660VAC
	Frequency	50/60 HZ ± 5%
	Phase	Three phase (or single phase power with derating)
	Impedance	1% minimum from mains connection
<b>Output Ratings</b>	Horsepower	$\frac{3}{4}$ -50 HP @ 240VAC $\frac{3}{4}$ -60 HP @ 480VAC $\frac{3}{4}$ -60 HP @ 600VAC
	Overload Capacity	Constant Torque = 150% for 60 seconds, 175% for 3 seconds Variable Torque = 115% for 60 seconds
	Frequency	0–500Hz
	Voltage	0 to Maximum Input voltage (RMS)
<b>Control Specifications</b>	Control Method	Microprocessor controlled PWM output, selectable closed loop vector; encoderless vector; or V/Hz inverter
	PWM Frequency	Adjustable 1–5kHz STD, 5–16 kHz quiet
	Speed Setting	±5 VDC, 0–5 VDC ±10 VDC, 0–10 VDC, 4–20 mA; digital (keypad), Serial Comms/USB 2.0, and Modbus RTU standard
	Accel/Decel	0–3600 seconds
	Motor Matching	Automatic tuning to motor with manual override
	PC Setup Software	Workbench software available using USB2.0 port for commissioning wizard, firmware download, parameter viewer, scope capture and cloning
<b>Motor Feedback</b>	Feedback Type	Incremental encoder coupled to motor shaft; optional resolver feedback
	Pulses/Rev	60–20,000 selectable, 1024 standard
	Voltage Output	2 channel in quadrature, 5 VDC or 12VDC, differential
	Marker Pulse	Required for position orientation
	Power	5 VDC, 250 mA maximum/ 12V, 200 mA maximum
	Max. Frequency	4 MHz
	Positioning	Optional buffered encoder pulse train output for position loop controller
<b>Protective Features</b>	Vector Trip	Missing control power, over current, over voltage, under voltage, motor over speed, encoder loss Over temperature (motor or control), output shorted or grounded, motor overload
	External Output	LED trip condition indicators, 4 assignable logic outputs, 2 assignable analog outputs 0–10 VDC, ±10 VDC
	Short Circuit	Phase to phase, phase to ground
<b>LED Display</b>	Running	Output frequency, motor RPM; output current, voltage (selectable), power, energy consumed
	Setting	Parameter values for setup and review
	Trip	Separate message for each trip, last 10 trips retained in memory
<b>Environmental Conditions</b>	Temperature	–10 to 45 °C Derate 3% per degree C above 45 to 55 °C maximum ambient temperature.
	Cooling	Forced air included when required
	Enclosure	NEMA 1: E, ER and EO (suffix) Models Protected chassis: M and MO (suffix) Models
	Altitude	Sea level to 3300 Feet (1000 Meters) Derate 2% per 1000 Feet (303 Meters) above 3300 Feet
	Humidity	10 to 90% RH Non-Condensing
	Shock	1G
	Vibration	0.5G at 10Hz to 60Hz
	Storage Temperature	–10 to +65 °C
Duty Cycle	1.0	

## Specifications Continued

<b>Keypad Display</b>	Display	LCD Graphical 128x64 Pixel
	Keys	14 key membrane with tactile response
	Functions	Output status monitoring Digital speed control Parameter setting and display Diagnostic and Fault log display Motor run and jog Local/Remote toggle
	LED Indicators	Forward run command Reverse run command Stop command Jog active
	Remote Mount	100 feet (30.3m) max from control
<b>Control Specifications</b>	Control Method	PWM
	Velocity Loop Bandwidth	Adjustable to 180 Hz (Control only)
	Current Loop Bandwidth	Adjustable to 1200 Hz (Control only)
	Maximum Output Frequency	500 Hz
	Quiet PWM Frequency Version	Full rating 2-8 kHz PWM frequency, Adjustable to 16 kHz with linear derating (between 8 - 16kHz) of 30% at 16 kHz
	Standard PWM Frequency Version	Full rating 1-2.5 kHz PWM frequency, Adjustable to 5 kHz with linear derating (between 2.5 - 5kHz) of 10% at 5 kHz
	Selectable Operating Modes	Keypad Standard Run, 2 Wire Standard Run, 3 Wire 15 Speed, 2 Wire Fan Pump 2 Wire Fan Pump 3 Wire Process Mode 3 SPD ANA 2 Wire 3 SPD ANA 3 Wire Electronic Pot 2 Wire Electronic Pot 3 Wire Bipolar Network Profile Run Mint
<b>Differential Analog Input</b>	Common Mode Rejection	40 db
	Full Scale Range	$\pm 5\text{VDC}$ , $\pm 10\text{VDC}$ , 4-20 mA and 0-20 mA
	Resolution	11 bits + sign
<b>Single Ended Analog Input</b>	Full Scale Range	0 - 10 VDC (0 to -10VDC and 0 to +10VDC are valid inputs), 4-20 mA and 0-20 mA
	Resolution	11 bits + sign
<b>Analog Outputs</b>	Analog Outputs	2 Assignable
	Full Scale Range	$\pm 10\text{ VDC}$
	Source Current	1 mA maximum
	Resolution	9 bits + sign

## Specifications Continued

<b>Digital Inputs</b>	Opto-isolated Inputs	9 Assignable
	Rated Voltage	10 - 30 VDC (closed contacts std)
	Input Impedance	4.71 k Ohms
	Leakage Current	10 $\mu$ A maximum
	Update Rate	16 msec
<b>Digital Outputs (2 Opto Outputs)</b>	Rated Voltage	5 to 30VDC
	Maximum Current	60 mA Maximum
	ON Voltage Drop	2 VDC Maximum
	OFF Leakage Current	0.1 $\mu$ A Maximum
	Output Conditions	25 Conditions (see Output Block parameter table, Table B-1)
<b>Digital Outputs (2 Relay Outputs)</b>	Rated Voltage	5 to 30VDC or 240VAC
	Maximum Current	5A Maximum non-inductive
	Output Conditions	25 Conditions (see Output Block parameter table, Table B-1)

## Diagnostic Indications:

Current Sense Fault	Regeneration (db) Overload	Following Error
Ground Fault	Soft Start Fault	Encoder Loss
Instantaneous Over Current	Under Voltage	Logic Power Fault
Overload	Ready	PWR Base Fault
Line Power Loss	Parameter Loss	
Microprocessor Failure	Overload	
Over temperature (Motor or Control)	Overvoltage	
Over speed	Torque Proving	

Note: All specifications are subject to change without notice.





## Ratings Series H2 Stock Products

Catalog No.	Input Volt	Size	Standard 2.5 kHz PWM									
			Constant Torque					Variable Torque				
			Input Amp	Output				Input Amp	Output			
				HP	KW	IC	IP		HP	KW	IC	IP
ZHH201-E	240	AA	4.2	1	0.75	4.2	7.4	6.8	2	1.5	6.8	7.8
ZHH202-E	240	AA	6.8	2	1.5	6.8	11.9	9.6	3	2.2	9.6	11
ZHH203-E	240	AA	9.6	3	2.2	9.6	16.8	16.5	5	3.7	15.2	17.5
ZHH205-E	240	AA	15.2	5	3.7	15.2	26.6	22	7 1/2	5.6	22	25.3
ZHH207-E	240	AA	22	7 1/2	5.6	22	38.5	22	7 1/2	5.6	22	25.3
ZHH210-E	240	B	28	10	7.5	28	49	42	15	11	42	48
ZHH215-E	240	B	42	15	11	42	74	42	15	11	42	48
ZHH220-E	240	B	57	20	15	55	96	70	25	18.5	68	78
ZHH225-E	240	C	70	25	18.5	68	119	82	30	22	80	92
ZHH230-E	240	C	82	30	22	80	140	82	30	22	80	92
ZHH240-M	240	C	108	40	30	105	184	134	50	37	130	150
ZHH250-M	240	C	134	50	37	130	228	134	50	37	130	150
ZHH401-E	480	AA	2.1	1	0.75	2.1	3.7	3.4	2	1.5	3.4	3.9
ZHH402-E	480	AA	3.4	2	1.5	3.4	6.0	4.8	3	2.2	4.8	5.5
ZHH403-E	480	AA	4.8	3	2.2	4.8	8.4	7.6	5	3.7	7.6	8.8
ZHH405-E	480	AA	7.6	5	3.7	7.6	13.3	11.0	7 1/2	5.6	11	12.7
ZHH407-E	480	AA	11.0	7 1/2	5.6	11	19.3	14	10	7.5	14	16.1
ZHH410-E	480	B	14.4	10	7.5	14	25	21.6	15	11	21	24
ZHH415-E	480	B	21.6	15	11	21	37	28	20	15	27	31
ZHH420-E	480	B	28	20	15	27	47	35	25	18.5	34	39
ZHH425-E	480	B	35	25	18.5	34	60	41	30	22	40	46
ZHH430-E	480	C	41	30	22	40	70	54	40	30	52	60
ZHH440-E	480	C	54	40	30	52	91	54	40	30	65	75
ZHH450-E	480	C	67	50	37	65	114	82	60	45	77	89
ZHH501-E	600	AA	1.7	1	0.75	1.7	3.0	2.7	2	1.5	2.7	3.1
ZHH502-E	600	AA	2.7	2	1.5	2.7	4.7	3.9	3	2.2	3.9	4.5
ZHH503-E	600	AA	3.9	3	2.2	3.9	6.8	6.1	5	3.7	6.1	7.0
ZHH505-E	600	AA	6.1	5	3.7	6.1	10.7	9	7 1/2	5.6	9	10.4
ZHH507-E	600	AA	9.0	7 1/2	5.6	9	15.8	11	10	7.5	11	12.7
ZHH510-E	600	B	11.3	10	7.5	11	19	17.5	15	11	17	20
ZHH515-E	600	B	17.5	15	11	17	30	23	20	15	22	25
ZHH520-E	600	B	23	20	15	22	39	28	25	18.5	27	31
ZHH525-E	600	B	28	25	18	27	47	28	25	18.5	27	31
ZHH530-E	600	C	33	30	22	32	56	42	40	30	41	47
ZHH540-E	600	C	42	40	30	41	72	56	50	37	52	60
ZHH550-E	600	C	56	50	37	52	91	67	60	45	62	71

**Ratings Series H2 Stock Products** Continued

Catalog No.	Input Volt	Size	Quiet 8.0 kHz PWM									
			Constant Torque					Variable Torque				
			Input Amp	Output				Input Amp	Output			
				HP	KW	IC	IP		HP	KW	IC	IP
ZHH201-E	240	AA	3.2	0.75	0.56	3.2	5.6	4.2	1	0.75	4.2	4.8
ZHH202-E	240	AA	4.2	1	0.75	4.2	7.4	6.8	2	1.5	6.8	7.8
ZHH203-E	240	AA	6.8	2	1.5	6.8	11.9	9.6	3	2.2	9.6	11.0
ZHH205-E	240	AA	9.6	3	2.2	9.6	16.8	15.2	5	3.7	15.2	17.5
ZHH207-E	240	AA	15.2	5	3.7	15.2	26.6	22	7 1/2	5.6	22	25.3
ZHH210-E	240	B	22	7 1/2	5.6	22	39	28	10	7.5	28	32
ZHH215-E	240	B	28	10	7.5	28	49	42	15	11	42	48
ZHH220-E	240	B	42	15	11	42	74	56	20	15	54	62
ZHH225-E	240	C	56	20	15	54	95	72	25	18.5	68	78
ZHH230-E	240	C	72	25	18.5	70	123	72	25	18.5	70	81
ZHH240-M	240	C	82	30	22	80	140	108	40	30	104	120
ZHH250-M	240	C	108	40	30	105	184	134	50	37	130	150
ZHH401-E	480	AA	2.1	1	0.75	2.1	3.7	2.1	1	0.75	2.1	2.4
ZHH402-E	480	AA	2.1	1	0.75	2.1	3.7	3.4	2	1.5	3.4	3.9
ZHH403-E	480	AA	3.4	2	1.5	3.4	6.0	4.8	3	2.2	4.8	5.5
ZHH405-E	480	AA	4.8	3	2.2	4.8	8.4	7.6	5	3.7	7.6	8.8
ZHH407-E	480	AA	7.6	5	3.7	7.6	13.3	11	7 1/2	5.6	11	12.7
ZHH410-E	480	B	11.3	7 1/2	5.6	11	19.3	15	10	7.5	14	16.1
ZHH415-E	480	B	15	10	7.5	14	25	22	15	11	21	24
ZHH420-E	480	B	22	15	11	21	37	28	20	15	27	31
ZHH425-E	480	B	28	20	15	27	47	35	25	18.5	34	39
ZHH430-E	480	C	35	25	18.5	34	60	41	30	22	40	46
ZHH440-E	480	C	41	30	22	40	70	41	30	22	52	60
ZHH450-E	480	C	45			44	77	53			52	60
ZHH501-E	600	AA	1.7	1	0.75	1.7	3.0	1.7	1	0.75	1.7	2.0
ZHH502-E	600	AA	1.7	1	0.75	1.7	3.0	2.7	2	1.5	2.7	3.1
ZHH503-E	600	AA	2.7	2	1.5	2.7	4.7	3.9	3	2.2	3.9	4.5
ZHH505-E	600	AA	3.9	3	2.2	3.9	6.8	6.1	5	3.7	6.1	7.0
ZHH507-E	600	AA	6.1	5	3.7	6.1	10.7	9	7 1/2	5.6	9	10.4
ZHH510-E	600	B	9.3	7 1/2	5.6	9	15.8	11.3	10	7.5	11	12.7
ZHH515-E	600	B	11.3	10	7.5	11	19.3	18	15	11	17	19.6
ZHH520-E	600	B	18	15	11	17	30	23	20	15	22	25
ZHH525-E	600	B	23	20	15	22	39	28	25	18.5	27	31
ZHH530-E	600	C	28	25	18.5	27	47	33	30	22	32	37
ZHH540-E	600	C	28	25	18.5	27	47	33	30	22	32	37
ZHH550-E	600	C	42	40	30	41	72	54	50	37	52	60

## Terminal Tightening Torque Specifications

240 VAC Catalog No.	Tightening Torque									
	Power TB1		Ground		Control J1, J2, J3		B+/R1; B+; B-; or R2		TH1 and TH2	
	Lb-in	Nm	Lb-in	Nm	Lb-in	Nm	Lb-in	Nm	Lb-in	Nm
ZHH201-E	8	0.9	15	1.7	4.5	0.5	8	0.9	4	0.45
ZHH202-E	8	0.9	15	1.7	4.5	0.5	8	0.9	4	0.45
ZHH203-E	8	0.9	15	1.7	4.5	0.5	8	0.9	4	0.45
ZHH205-E	8	0.9	15	1.7	4.5	0.5	8	0.9	4	0.45
ZHH207-E	8	0.9	15	1.7	4.5	0.5	8	0.9	4	0.45
ZHH210-E	35	4	50	5.6	4.5	0.5	35	4	4	0.45
ZHH215-E	35	4	50	5.6	4.5	0.5	35	4	4	0.45
ZHH220-E	35	4	50	5.6	4.5	0.5	35	4	4	0.45
ZHH225-E	50	5.6	50	5.6	4.5	0.5	50	5.6	4	0.45
ZHH230-E	50	5.6	50	5.6	4.5	0.5	50	5.6	4	0.45
ZHH240-M	50	5.6	50	5.6	4.5	0.5	50	5.6	4	0.45
ZHH250-M	50	5.6	50	5.6	4.5	0.5	50	5.6	4	0.45
ZHH401-E	8	0.9	15	1.7	4.5	0.5	8	0.9	4	0.45
ZHH402-E	8	0.9	15	1.7	4.5	0.5	8	0.9	4	0.45
ZHH403-E	8	0.9	15	1.7	4.5	0.5	8	0.9	4	0.45
ZHH405-E	8	0.9	15	1.7	4.5	0.5	8	0.9	4	0.45
ZHH407-E	8	0.9	15	1.7	4.5	0.5	8	0.9	4	0.45
ZHH410-E	8	0.9	15	1.7	4.5	0.5	8	0.9	4	0.45
ZHH415-E	35	4	50	5.6	4.5	0.5	35	4	4	0.45
ZHH420-E	35	4	50	5.6	4.5	0.5	35	4	4	0.45
ZHH425-E	35	4	50	5.6	4.5	0.5	35	4	4	0.45
ZHH430-E	50	5.6	50	5.6	4.5	0.5	50	5.6	4	0.45
ZHH440-E	50	5.6	50	5.6	4.5	0.5	50	5.6	4	0.45
ZHH450-E	50	5.6	50	5.6	4.5	0.5	50	5.6	4	0.45
ZHH501-E	8	0.9	15	1.7	4.5	0.5	8	0.9	4	0.45
ZHH502-E	8	0.9	15	1.7	4.5	0.5	8	0.9	4	0.45
ZHH503-E	8	0.9	15	1.7	4.5	0.5	8	0.9	4	0.45
ZHH505-E	8	0.9	15	1.7	4.5	0.5	8	0.9	4	0.45
ZHH507-E	8	0.9	15	1.7	4.5	0.5	8	0.9	4	0.45
ZHH510-E	8	0.9	15	1.7	4.5	0.5	8	0.9	4	0.45
ZHH515-E	35	4	50	5.6	4.5	0.5	35	4	4	0.45
ZHH520-E	35	4	50	5.6	4.5	0.5	35	4	4	0.45
ZHH525-E	35	4	50	5.6	4.5	0.5	35	4	4	0.45
ZHH530-E	50	5.6	50	5.6	4.5	0.5	50	5.6	4	0.45
ZHH540-E	50	5.6	50	5.6	4.5	0.5	50	5.6	4	0.45
ZHH550-E	50	5.6	50	5.6	4.5	0.5	50	5.6	4	0.45

**Mounting Dimensions**

**Size AA, B and C Controls**

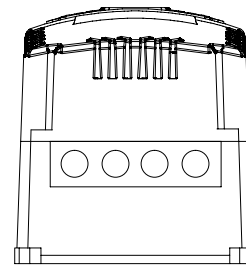
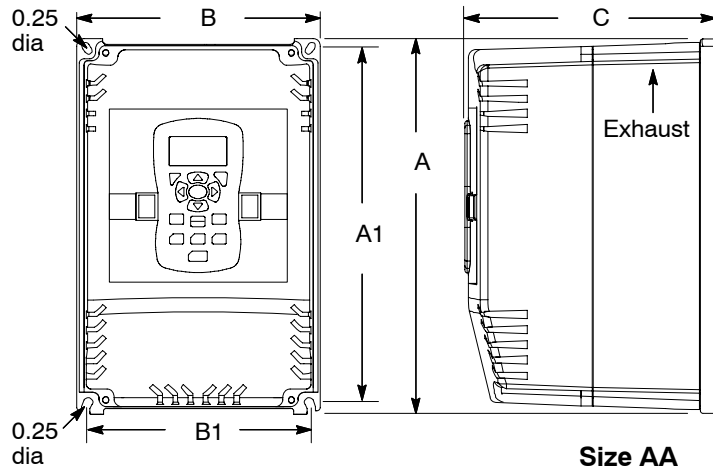

Size	# Holes	Diameter inches (mm)
AA	4	0.6 (15)

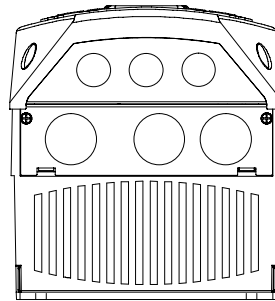
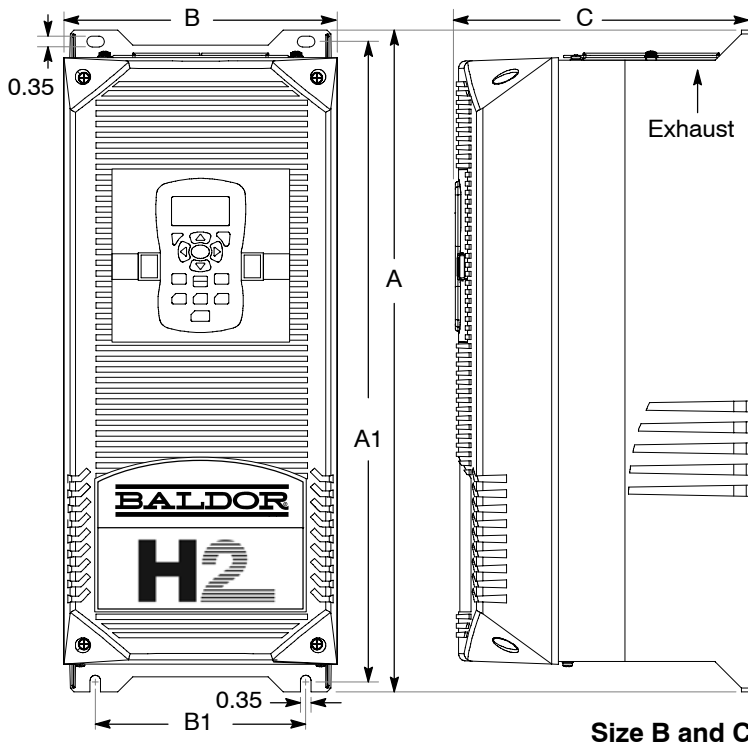

Size	# Holes	Diameter inches (mm)
B	3	0.6 (15)
B	3	1.25 (32)
C	3	0.6 (15)
C	3	1.68 (42)

Size	Dimensions inches(mm)				
	Outside			Mounting	
	Height (A)	Width (B)	Depth (C)	Height (A1)	Width (B1)
AA	12.27 (311)	7.97 (202)	8.21 (208)	11.75 (298)	7.38 (187)
B	18.00 (457)	9.10 (231)	9.48 (241)	17.25 (438)	7.00 (178)
C	22.00 (559)	9.10 (231)	9.77 (248)	21.25 (540)	7.00 (178)

# Appendix A

## Optional Equipment

**Dynamic Braking (DB) Hardware** Whenever a motor is abruptly stopped or forced to slow down quicker than if allowed to coast to a stop, the motor becomes a generator. This energy appears on the DC Bus of the control and must be dissipated using dynamic braking hardware.

Dynamic braking resistors are completely assembled and mounted in a NEMA 1 enclosure. A listing of available RGA assemblies is provided in Table A-1. Select the braking resistor that has correct ohm value for the control and adequate continuous watts capacity to meet load requirements.

**Table A-1 Dynamic Braking Resistor Assemblies (RGA)**

Input Volts	HP	Total Ohms	Continuous Rated Watts			
			600	1200	2400	4800
230	1 - 2	30	RGA630	RGA1230	RGA2430	
	3 - 7.5	20	RGA620	RGA1220	RGA2420	RGA4820
	10	10		RGA1210	RGA2410	RGA4810
	15 - 20	6		RGA1206	RGA2406	RGA4806
	25 - 40	4		RGA1204	RGA2404	RGA4804
	50	4			RGA2402	RGA4802
460	1 - 3	120	RGA6120	RGA12120	RGA24120	
	5 - 10	60	RGA660	RGA1260	RGA2460	RGA4860
	15 - 25	20	RGA620	RGA1220	RGA2420	RGA4820
	30 - 50	10		RGA1210	RGA2410	RGA4810
575	1 - 2	200	RGA6200	RGA12200	RGA24200	
	3 - 5	120	RGA6120	RGA12120	RGA24120	
	7.5 - 10	60	RGA660	RGA1260	RGA2460	RGA4860
	15 - 25	30	RGA630	RGA1230	RGA2430	RGA4830
	20 - 30	24		RGA1224	RGA2424	RGA4824
	40 - 50	14			RGA2414	RGA4814

### Keypad Extension Cable

For the convenience of our customers, we offer a connector plug/cable assembly. This assembly provides the connectors from the keypad to the control for remote keypad operation.

**Table A-1 Keypad Extension Cable Selection**

Catalog Number	Length
CBLHH015KP	5 ft (1.5m)
CBLHH030KP	10 ft (3.0m)
CBLHH046KP	15 ft (4.6m)
CBLHH061KP	20 ft (6.1m)
CBLHH091KP	30 ft (9.1m)
CBLHH152KP	50 ft (15.2m)
CBLHH229KP	75 ft (22.9m)
CBLHH305KP	100 ft (30.5m)

## Expansion Boards

Baldor offers a wide variety of plug-in expansion boards for the Series H2 Controls. Expansion boards allow a control to be compatible with various inputs and outputs. Each control can accept up to two expansion boards. Section 3 of this manual describes the locations of the connectors for these expansion boards.

**Table A-2 Expansion Board Descriptions**

Catalog Number	Description												
EXBHH001A01 or later	Ethernet Server Expansion Board Uses standard RJ-45 female terminal for ethernet connection. Provides easy connection to any PC based Web Browser that has an Ethernet connection. Allows you to quickly access all drive parameters for setup and review. Download parameter values, operating conditions, and fault log data for review and archive.												
EXBHH002A01 or later	Mint® Expansion Board Provides standalone single axis Position Control and is programmable in Mint® language. Position capabilities include Master Axis Follower, Electronic Gearbox, Flying Shears, Registration, Virtual Master, and CAM functions. Uses MINT Workbench V5 for setup and diagnostics. Master encoder input supports differential inputs for A, B and C (Index pulse). Uses DB9 for connection. One CAN open channel is available for connection to additional I/O breakout box or CAN HMI terminal. Connection to PC is by USB1.1 connector. Includes CD Rom and 2m USB cable.												
EXBHH003A01 or later	Isolated Input Expansion Board Contains 9 isolated inputs, jumper configurable for 90-130 VAC. All inputs must be the same voltage. One side of all inputs is common. This board replaces all the opto inputs on the main control board. Uses screw terminals for connection.												
EXBHH005A01 or later	High resolution analog board Allows one input with up to 16 bits resolution. DC inputs: ±10V, 0-10V, ±5V, 0-5V, with 300 microvolt resolution. Current inputs: 4-20 mA, with 0.6 microamps resolution. <table border="1" style="margin-left: 40px;"> <thead> <tr> <th>Input</th> <th>Resolution</th> </tr> </thead> <tbody> <tr> <td>±10 V</td> <td>16 bit</td> </tr> <tr> <td>0 - 10 V</td> <td>15 bit</td> </tr> <tr> <td>±5 V</td> <td>15 bit</td> </tr> <tr> <td>0 - 5 V</td> <td>14 bit</td> </tr> <tr> <td>4 - 20 mA</td> <td>15 bit</td> </tr> </tbody> </table> Both the 0-10 V and 4-20 mA inputs may be inverted to 10-0 V and 20-4 mA. Two outputs, each with ±10 VDC, 0-10 VDC or 4-20 mA with inverting capability. This replaces the analog outputs on the main control board. Uses screw terminals for connection.	Input	Resolution	±10 V	16 bit	0 - 10 V	15 bit	±5 V	15 bit	0 - 5 V	14 bit	4 - 20 mA	15 bit
Input	Resolution												
±10 V	16 bit												
0 - 10 V	15 bit												
±5 V	15 bit												
0 - 5 V	14 bit												
4 - 20 mA	15 bit												
EXBHH007A01 or later	Master Pulse Reference / Isolated Pulse Follower Jumper selection of the following modes: <ol style="list-style-type: none"> <li>1. Master quadrature pulse reference. Provides 5 volt quadrature A and B channel outputs with complements at a pulse rate proportional to accel-decel limited speed commands. Phase of B channel is reversed for reverse direction.</li> <li>2. Master speed step-direction pulse reference. Provides 5 volt pulse and direction outputs with complements at a pulse rate proportional to accel-decel limited speed command.</li> <li>3. Quadrature pulse follower. Provides opto isolated inputs for 5-15 volt quadrature A and B channel input speed commands and retransmits this input as 5 volt channel A and B outputs with complements at a pulse rate proportional to accel-decel limited speed command. Motor direction reverses with input channel phase reversal.</li> <li>4. Speed step and direction pulse follower. Provides opto isolated inputs for 5-15 volt input pulse and direction. Commands and retransmits these inputs as 5 volt pulse and direction outputs with complements at a pulse rate proportional to accel-decel limited speed command.</li> </ol>												
EXBHH012A01 or later	Ethernet IP Communications Expansion Board Allows connection to Ethernet IP Communications Bus. Uses plug-in terminals for connection.												
EXBHH013A01 or later	DeviceNet Expansion Board Allows connection to DeviceNet Communications Bus. Uses plug-in terminals for connection.												
EXBHH014A01 or later	Profibus DP Expansion Board Allows connection to Profibus Communications Bus. Uses plug-in terminals for connection.												
EXBHH016A01 or later	LonWorks Communications Expansion Board Allows connection to LonWorks Communications Bus. Uses plug-in terminals for connection.												

# Appendix B

## Parameter Values (Version 1.01)

All parameters displayed in this appendix are Parameter Table 1 (T1) factory set values.  
 Setting parameter P2103 to yes will load these values into all four parameter tables.  
 Level 1 & 2 parameters are secured by security access code (P2109).

**Table B-1 Parameter Block Values Level 1**

Block Title	Parameter	P#	Adjustable Range	Factory	User Setting
PRESET SPEEDS	PRESET SPEED 1	1001	0-MAX Speed	30	
	PRESET SPEED 2	1002	0-MAX Speed	60	
	PRESET SPEED 3	1003	0-MAX Speed	90	
	PRESET SPEED 4	1004	0-MAX Speed	120	
	PRESET SPEED 5	1005	0-MAX Speed	150	
	PRESET SPEED 6	1006	0-MAX Speed	180	
	PRESET SPEED 7	1007	0-MAX Speed	210	
	PRESET SPEED 8	1008	0-MAX Speed	240	
	PRESET SPEED 9	1009	0-MAX Speed	270	
	PRESET SPEED 10	1010	0-MAX Speed	300	
	PRESET SPEED 11	1011	0-MAX Speed	330	
	PRESET SPEED 12	1012	0-MAX Speed	360	
	PRESET SPEED 13	1013	0-MAX Speed	390	
	PRESET SPEED 14	1014	0-MAX Speed	420	
	PRESET SPEED 15	1015	0-MAX Speed	450	
RAMP RATES	ACCEL TIME 1	1101	0.0 to 3600.0 Seconds	3.0	
	START S-ACCEL 1	1102	0-100%	0.0	
	END S-ACCEL 1	1103	0-100%	0.0	
	DECEL TIME 1	1104	0.0 to 3600.0 Seconds	3.0	
	START S-DECEL 1	1105	0-100%	0.0	
	END S-DECEL 1	1106	0-100%	0.0	
	ACCEL TIME 2	1107	0.0 to 3600.0 Seconds	3.0	
	START S-ACCEL 2	1108	0-100%	0.0	
	END S-ACCEL 2	1109	0-100%	0.0	
	DECEL TIME 2	1110	0.0 to 3600.0 Seconds	3.0	
	START S-DECEL 2	1111	0-100%	0.0	
	END S-DECEL 2	1112	0-100%	0.0	
JOG SETTINGS	JOG SPEED	1201	0-MAX Speed	210	
	JOG ACCEL TIME	1202	0.0 to 3600.0 Seconds	10.0	
	JOG START S-ACCEL	1203	0-100%	0.0	
	JOG END S-ACCEL	1204	0-100%	0.0	
	JOG DECEL TIME	1205	0.0 to 3600.0 Seconds	10.0	
	JOG START S-DECEL	1206	0-100%	0.0	
	JOG END S-DECEL	1207	0-100%	0.0	
	JOG FORWARD	1209	0-OFF, 1-ON	1	
	JOG REVERSE	1210	0-OFF, 1-ON	1	

**Table B-1 Parameter Block Values Level 1** Continued

Block Title	Parameter	P#	Adjustable Range	Factory	User Setting
KEYPAD SETUP	STOP KEY	1301	0-OFF (Stop key inactive during remote operation). 1-ON (Stop key active during remote operation).	1	
	STOP MODE	1302	0-Coast, 1-Regen	1	
	RUN FORWARD	1303	0-OFF, 1-ON	1	
	RUN REVERSE	1304	0-OFF, 1-ON	1	
	SWITCH ON FLY	1305	0-OFF, 1-ON	0	
	LOCAL HOT START	1306	0-OFF, 1-ON	0	
	SPEED INCREMENT	1307	1 TO 1800 RPM	30	
	INIT LOCAL SPEED	1308	0-Zero, 1-Last Speed, 2-Set Speed	0	
	SET SPEED	1309	0-MAX Speed	30	
	PARAMS TO KEYPAD	1310	0-NO, 1-YES	0	
	KEYPAD TO PARAMS	1311	0-NO, 1-YES	0	
	KEYPAD CONTRAST	1312	0-100% (0=dimmest, 100=brightest)	50	
	BACKLIGHT	1314	0-OFF, 1-ON	1	
	③ LOCAL TORQUE MODE	1315	0-OFF, 1-ON	0	
	③ LOCAL TORQUE REF	1316	-100.00 TO 100.00%	0.00	
INPUT SETUP	OPERATING MODE	1401	0-KEYPAD 1-STANDARD RUN 2-15 SPEED 3-FAN PUMP 2WIRE 4-FAN PUMP 3WIRE 5-PROCESS CONTROL 6-3SPD ANA 2WIRE 7-3SPD ANA 3WIRE 8-EPOT -2WIRE 9-EPOT -3WIRE 10-NETWORK 11-PROFILE RUN 12-MINT 13-BIPOLAR	0	
	COMMAND SOURCE	1402	0-NONE 1-ANALOG INPUT1 2-ANALOG INPUT2 3-KEYPAD 4-NETWORK	1	
	ANA IN1 TYPE	1403	0-NONE, 1-POTENTIOMETER	1	
	ANA IN1 INVERT	1404	0-OFF, 1-ON	0	
	ANA IN1 GAIN	1405	0.0% TO 300.0%	100.0	
	ANA IN1 OFFSET	1406	-100.0% TO 100.0%	0.0	
	ANA IN1 FILTER	1407	0 (No Filter) TO 6 (Max Filter)	0	
	ANA IN2 TYPE	1408	0-None, 1-(-10V to+10V), 2-(-5V to+5V), 3-(4to20mA), 4-(0to20mA)	1	
	ANA IN2 INVERT	1409	0-OFF, 1-ON	0	
	ANA IN2 GAIN	1410	0.0% TO 300.0%	100.0	
	ANA IN2 OFFSET	1411	-100.0% TO 100.0%	0.0	
	ANA IN2 DEADBAND	1412	0.0% TO 100.0%	0.0	
	ANA IN2 FILTER	1413	0 (No Filter) TO 6 (Max Filter)	0	
	③ EXT. CURRENT LIMIT	1414	0-OFF, 1-ON	0	
	③ CURRENT LIMIT SOURCE	1415	0-None, 1-Analog In1, 2-Analog In2, 3-Keypad, 4-Network	0	

① Only available or active in Closed Loop Vector mode. Ignore these parameters for Open Loop Vector and V/F modes.

② Only available or active in V/F mode. Ignore these parameters for Open Loop Vector mode.

③ Only available or active in either Vector mode. Ignore these parameters for V/F mode.



**Table B-1 Parameter Block Values Level 1** Continued

Block Title	Parameter	P#	Adjustable Range	Factory	User Setting
OUTPUT SETUP	DIGITAL OUTPUT 1	1501	0-DRIVE RUN 1-DRIVE READY 2-DRIVE ON 3-DRIVE STOPPED 4-JOG 5-ACCELERATE	1	
	DIGITAL OUTPUT 2	1502	6-CONSTANT SPEED 7-DECELERATE 8-AT ZERO SPEED 9-AT SPEED 10-AT SET SPEED 11-CURRENT OVERLOAD 12-CURRENT UNDERLOAD	8	
	RELAY OUTPUT 1	1503	13-I <sup>2</sup> T OVERLOAD 14-KEYPAD CONTROL 15-DYNAMIC BRAKE 16-FOLDBACK 17-FAULT 18-WARNING	9	
	RELAY OUTPUT 2	1504	19-COMMAND FORWARD 20-COMMAND REVERSE 21-MOTOR FORWARD 22-MOTOR REVERSE 23-PROCESS ERROR 24-NETWORK	17	
	ZERO SPD SET PT	1505	0-MAX Speed	180	
	AT SPEED BAND	1506	0-100 RPM	60	
	SET SPEED POINT	1507	0-MAX Speed	1800	
	OVERLOAD SET POINT	1508	0.0-200.0%	150.0	
	UNDERLOAD SET POINT	1509	0.0-200.0%	50.0	
	ANALOG OUT1 TYPE	1510	0-(0 TO +10V), 1-(0 TO 5V), 2-(4mA TO 20mA), 3-(0mA TO 20mA)	0	

**Table B-1 Parameter Block Values Level 1** Continued

Block Title	Parameter	P#	Adjustable Range	Factory	User Setting
OUTPUT SETUP	ANALOG OUT1 SIGNAL	1511	0-SPEED REF 1-SPEED DEMAND 2-ACC/DEC 3-MOTOR CURRENT 4-MAG CURRENT 5-MAG CURRENT COMMAND 6-LOAD CURRENT 7-LOAD CURRENT COMMAND 8-POWER 9-PH1 CURRENT 10-PH2 CURRENT 11-PH3 CURRENT 12-MOTOR VOLTAGE 13-VD DEMAND 14-VQ DEMAND 15-BUS VOLTAGE 16-ABS TORQUE	29	
	ANALOG OUT2 SIGNAL	1514	17-TORQUE 18-CONTROL TEMP 19-ANALOG INPUT1 20-ANALOG INPUT2 21-OPT1 ANA IN1 22-OPT1 ANA IN2 23-OPT2 ANA IN1 24-OPT2 ANA IN2 25-PROC FEEDFORWARD 26-PROC FEEDBACK 27-PROC SETPOINT 28-ELECTRIC ANGLE 29-ABS SPEED 30-VELOCITY 31-NETWORK 32-CALIBRATE	3	
	ANALOG OUT1 GAIN	1512	0 - 200.0%	100.0	
	ANALOG OUT2 TYPE	1513	0-(+/-5V), 1-(+/-10V)	1	
	ANALOG OUT2 GAIN	1515	1-200.0%	100.0	
	CALIBRATE ANALOG OUT	1516	-100.0% TO 100.0%	0.0	

**Table B-1 Parameter Block Values Level 1** Continued

Block Title	Parameter	P#	Adjustable Range	Factory	User Setting
MOTOR CONTROL	CONTROL TYPE	1601	0-V/F Control, 1-Open Vector, 2-Closed Vector	2	
	CONTROL BASE SPEED	1602	0-MAX Speed	1800	
	② CONTROL BASE VOLTS	1611	0- Motor Voltage (P2401)	CALC	
	② STATIC BOOST	1612	0.0-15.0%	0.0	
	② DYNAMIC BOOST CUT IN	1613	6.00-60.00 Hz	30.00	
	② DYNAMIC BOOST	1614	0.0-10.0%	0.0	
	② V/F EFFICIENCY	1615	0-OFF, 1-ON	0	
	② V/F PROFILE	1616	0-100%	0	
	② 3 POINT METHOD	1617	0-OFF, 1-ON	0	
	② 3 POINT VOLTAGE	1618	0.0-100.0%	0.0	
	② 3 POINT FREQUENCY	1619	0.00-60.00 Hz	30.00	
	② SLIP COMP ENABLE	1620	0-OFF, 1-ON	0	
	① FEEDBACK ALIGN	1631	0-Forward, 1-Reverse	0	
	① FEEDBACK FILTER	1632	1-7	4	
	③ CURRENT PROP GAIN	1633	0-255	CALC	
	③ CURRENT INT GAIN	1634	0.0-500.00Hz	135.01	
	③ SPEED PROP GAIN	1635	0.0-255.0	CALC	
	③ SPEED INT GAIN	1636	0.00-50.00Hz	10.00	
	③ SPEED DIFF GAIN	1637	0.00-200.00	0.00	
	① POSITION GAIN	1638	0.0-1000.0	8.0	
	③ A.S. PROP GAIN	1639	0.0-255.0	CALC	
	③ A.S. INTEGRAL GAIN	1640	0.00-200.00Hz	50.00	
	③ MOTOR Xm	1641	0.00-1000.00	CALC	
	③ MOTOR R1	1642	0.000-1000.000	CALC	
	③ MOTOR X1	1643	0.000-1000.000	CALC	
	③ ROTOR TIME CONSTANT	1644	0.000-60.000	CALC	
③ MOTOR R2	1645	0-1000	CALC		
③ MOTOR X2	1646	0-1000	CALC		
COMMUNICATION	BAUD RATE	1701	0-9600, 1-19200, 2-38400, 3-56000, 4-115200	1	
	PARITY	1702	0-None, 1-Odd, 2-Even	0	
	STOP BITS	1703	0-One, 1-Two	0	
	DRIVE ADDRESS	1704	1-247	1	
	IP ADDRESS	1705	000.000.000.000 to 255.255.255.255	000.000.000.000	
	SUBNET MASK	1706	000.000.000.000 to 255.255.255.255	000.000.000.000	
	GATEWAY MASK	1707	000.000.000.000 to 255.255.255.255	000.000.000.000	
	IP ADDRESS SOURCE	1708	0-Static, 1-Network	0	

- ① Only available or active in Closed Loop Vector mode. Ignore these parameters for Open Loop Vector and V/F modes.
- ② Only available or active in V/F mode. Ignore these parameters for Open Loop Vector mode.
- ③ Only available or active in either Vector mode. Ignore these parameters for V/F mode.

**Table B-2 Parameter Block Values Level 2**

Block Title	Parameter	P#	Adjustable Range	Factory	User Setting
DRIVE LIMITS	OPERATING ZONE	2001	0-STD CONST TORQUE 1-STD VAR TORQUE 2-QUIET CONST TORQUE 3-QUIET VAR TORQUE	0	
	MIN OUTPUT SPEED	2002	0-MAX Speed	0	
	MAX OUTPUT SPEED	2003	500-30000 RPM	Rated Motor Speed	
	PWM FREQUENCY	2004	1000 TO 16000Hz	2500	
	③ CUR RATE LIMIT	2005	0.000-10.000 seconds	0.004	
	PEAK CURRENT LEVEL	2006	0- Peak Rated Current	CALC	
	REGEN TORQUE LIMIT	2007	0.0-200.0%	CALC	
DRIVE CONFIGURE	SPEED UNITS	2101	0-Hz, 1-RPM	1	
	FACTORY SETTINGS	2103	0-NO, 1-YES	0	
	SECURITY	2105	0-Off, 1-Local, 2-Network, 3-Total	0	
	ACCESS TIMEOUT	2106	1.0-600.0 seconds	5.0	
	ACCESS CODE	2107	0-9999	9999	
	ACTIVE PARAMETER TABLE	0052	0-T1, 1-T2, 2-T3, 3-T4	0	
	CLEAR FAULT LOG	2108	0-NO, 1-YES	0	
	DEAD TIME COMP	2109	0-OFF, 1-ON	1	
	POWER INPUT	2110	0-Three (or Single) Phase, 1-Common Bus	0	
DRIVE PROTECT	EXTERNAL TRIP	2201	0-OFF, 1-ON	0	
	③ FOLLOWING ERROR	2202	0-OFF, 1-ON	0	
	③ TORQUE PROVING	2203	0-OFF, 1-ON	0	
	① ENCODER LOSS	2204	0-OFF, 1-ON	1	
	② FOLDBACK GAIN	2205	0.000-10.000%	0.100	
	OVERLOAD	2206	0-Fault, 1-Foldback, 2-Hold	1	
	② OVERLOAD TRIGGER	2207	0.0-100.0%	50.0	
	① ENCODER SENSE	2208	0-Manual, 1-Automatic	1	
	OVER TEMPERATURE	2210	0-Fault, 1-Derate	0	

① Only available or active in Closed Loop Vector mode. Ignore these parameters for Open Loop Vector and V/F modes.

② Only available or active in V/F mode. Ignore these parameters for Open Loop Vector mode.

③ Only available or active in either Vector mode. Ignore these parameters for V/F mode.

**Table B-2 Parameter Block Values Level 2** Continued

Block Title	Parameter	P#	Adjustable Range	Factory	User Setting
MISCELLANEOUS	AUTO RESTART	2301	0-Manual, 1-Automatic	0	
	RESTARTS/HOUR	2302	0-10	0	
	RESTART DELAY	2303	0-3600 seconds	3	
	PWM TECHNIQUE	2304	0-Space VECT, 1-Sine Triangle	1	
	COST OF ENERGY	2305	0.00-99999.00\$/KWH	0.10	
	RESET ENERGY	2306	0-NO, 1-YES	0	
	① HOMING SPEED	2307	0-MAX Speed	90	
	① HOMING OFFSET	2308	0-65535 counts	1024	
	FILTER TYPE	2309	0-None, 1-Low Pass, 2-High Pass, 3-Notch	0	
	FILTER SOURCE	2310	0-None, 1-Raw Speed, 2-Torque, 3-Analog IN1, 4-Analog IN2	0	
	FILTER DESTINATION	2311	0-None, 1-Speed Loop, 2-Torque Loop, 3-Speed FFWD, 4-Process FBK, 5-Process FFWD, 6-Process SP	0	
	FILTER CUTOFF	2312	0.00-1000.00Hz	0.00	
	NOTCH CENTER FREQ	2313	0.00-500.00Hz	0.00	
	NOTCH BAND	2314	0.00-200.00Hz	0.00	
MOTOR DATA	MOTOR RATED VOLT	2401	0-1000 Volts	CALC	
	MOTOR RATED AMPS	2402	0- AMP	CALC	
	MOTOR RATED SPEED	2403	0-30000 RPM	CALC	
	MOTOR RATED FREQUENCY	2404	0.00-120.00Hz	60.00	
	MOTOR MAG AMPS	2405	0- Amps	CALC	
	② INSTABILITY FREQUENCY	2406	0.00-500.00Hz	20.00	
	② STABILITY GAIN	2407	0.000-10.000	0.300	
	① ENCODER COUNTS	2408	50-20000 PPR	1024	
	① ENCODER SOURCE	2409	0-None, 1-Option Slot1, 2-Option Slot2, 3-Daughter FDBK	3	
	① ENCODER TYPE	2410	0-Single, 1-Differential	1	
	① RESOLVER SPEED	2411	0-10	0	
	ELECTRICAL SLIP FREQUENCY	2412	0.000-20.000	CALC	
	CALCULATE MOTOR MODEL	2413	0-NO, 1-YES	0	

① Only available or active in Closed Loop Vector mode. Ignore these parameters for Open Loop Vector and V/F modes.

② Only available or active in V/F mode. Ignore these parameters for Open Loop Vector mode.

③ Only available or active in either Vector mode. Ignore these parameters for V/F mode.

**Table B-2 Parameter Block Values Level 2** Continued

Block Title	Parameter	P#	Adjustable Range	Factory	User Setting
BRAKE ADJUST	RESISTOR OHMS	2501	0.00-255.0 Ohms	CALC	
	RESISTOR WATTS	2502	0-999999W	CALC	
	RESISTOR THERMAL TIME CONSTANT	2503	20-3600 seconds	CALC	
	② DC BRAKE VOLTS	2504	0-20%	0	
	② DC BRAKE TRIGGER	2505	0.00-50.00 Hz	0.00	
	② BRAKE ON STOP	2506	0-OFF, 1-ON	0	
	② BRAKE ON REVERSE	2507	0-OFF, 1-ON	0	
	② STOP BRAKE TIME	2508	0.0-60.0 seconds	0.0	
	② BRAKE ON START	2509	0-OFF, 1-ON	0	
	② START BRAKE TIME	2510	0.0-60.0 seconds	0.0	
PROCESS CONTROL	PROCESS TYPE	2601	0-None, 1-Forward Acting, 2-Reverse Acting	0	
	PROCESS FEEDFORWARD	2602	0-None, 1-Setpoint CMD, 2-Local Speed Ref. 3-Analog In1, 4-Analog In2, 5-Network	0	
	PROCESS FEEDBACK	2603		0	
	SETPOINT SOURCE	2604		0	
	SETPOINT COMMAND	2605	-100.0% to +100.0%	0.0	
	SETPOINT BAND	2606	0.0-100.0%	10.0	
	PROCESS PROP GAIN	2607	0.0000-9999.9990	10.0000	
	PROCESS INTG GAIN	2608	0.0000-9999.9990	0.0000	
	PROCESS INTG CLAMP	2609	0.0-100.0%	100.0	
	PROCESS DIFF GAIN	2610	0.0000-9999.9990	0.0000	
	ACC/DEC ADJUST	2611	0-NO, 1-YES	0	
	ERROR SWITCH POINT	2612	0-200.0%	50.0	
	PROCESS SLEEP BAND	2613	0-100.0%	0.0	
SKIP FREQUENCY ②	② SKIP FREQ 1	2701	0-MAX Speed	0.00	
	② SKIP BAND 1	2702	0-MAX Speed	0.00	
	② SKIP FREQ 2	2703	0-MAX Speed	0.00	
	② SKIP BAND 2	2704	0-MAX Speed	0.00	
	② SKIP FREQ 3	2705	0-MAX Speed	0.00	
	② SKIP BAND 3	2706	0-MAX Speed	0.00	
SYNCHRO START ②	② SYNC START FWD	2801	0-OFF, 1-ON	0	
	② SYNC START REV	2802	0-OFF, 1-ON	0	
	② START AT MAX FREQ	2803	0-OFF, 1-ON	1	
	② SYNC SCAN V/F	2804	1.0-100.0%	10.0	
	② SYNC SETUP TIME	2805	0.0-5.0 seconds	0.2	
	② SYNC SCAN TIME	2806	0.5-10.0 seconds	2.0	
	② SYNC RECOVER TIME	2807	0.5-10.0 seconds	1.0	

① Only available or active in Closed Loop Vector mode. Ignore these parameters for Open Loop Vector and V/F modes.

② Only available or active in V/F mode. Ignore these parameters for Open Loop Vector mode.

③ Only available or active in either Vector mode. Ignore these parameters for V/F mode.

**Table B-2 Parameter Block Values Level 2** Continued

Block Title	Parameter	P#	Adjustable Range	Factory	User Setting
AUTO TUNE	ANALOG OFFSET TRIM	2901	0-NO, 1-YES	0	
	③ ONE-STEP TUNING	2902	0-NO, 1-YES	0	
	STATOR R1 TUNE	2903	0-NO, 1-YES	0	
	③ MEASURE XM (ROT)	2904	0-NO, 1-YES	0	
	③ MEASURE LEAKAGE	2905	0-NO, 1-YES	0	
	③ CURRENT LOOP TUNE	2906	0-NO, 1-YES	0	
	③ FLUX CUR TUNE	2907	0-NO, 1-YES	0	
	① FEEDBACK TEST	2908	0-NO, 1-YES	0	
	① SLIP FREQUENCY TUNE	2909	0-NO, 1-YES	0	
	① SPEED LOOP TUNE	2910	0-NO, 1-YES	0	

**Table B-3 Parameter Block Values Level 3**

Block Title	Parameter	P#	Adjustable Range	Factory	User Setting
PROFILE RUN	NUMBER OF CYCLES	3001	0-255	0	
	PR RESTART MODE	3002	0-Restart, 1-Continue	0	
	SPEED CURVE 1	3003	0-FWD-Group1, 1-REV-Group1, 2-FWD-Group2, 3-REV-Group2	0	
	PROFILE TIME 1	3004	0-65535.00 seconds	0.00	
	SPEED CURVE 2	3005	0-FWD-Group1, 1-REV-Group1, 2-FWD-Group2, 3-REV-Group2	0	
	PROFILE TIME 2	3006	0-65535.00 seconds	0.00	
	SPEED CURVE 3	3007	0-FWD-Group1, 1-REV-Group1, 2-FWD-Group2, 3-REV-Group2	0	
	PROFILE TIME 3	3008	0-65535.00 seconds	0.00	
	SPEED CURVE 4	3009	0-FWD-Group1, 1-REV-Group1, 2-FWD-Group2, 3-REV-Group2	0	
	PROFILE TIME 4	3010	0-65535.00 seconds	0.00	
	SPEED CURVE 5	3011	0-FWD-Group1, 1-REV-Group1, 2-FWD-Group2, 3-REV-Group2	0	
	PROFILE TIME 5	3012	0-65535.00 seconds	0.00	
	SPEED CURVE 6	3013	0-FWD-Group1, 1-REV-Group1, 2-FWD-Group2, 3-REV-Group2	0	
	PROFILE TIME 6	3014	0-65535.00 seconds	0.00	
	SPEED CURVE 7	3015	0-FWD-Group1, 1-REV-Group1, 2-FWD-Group2, 3-REV-Group2	0	
	PROFILE TIME 7	3016	0-65535.00 seconds	0.00	

- ① Only available or active in Closed Loop Vector mode. Ignore these parameters for Open Loop Vector and V/F modes.
- ② Only available or active in V/F mode. Ignore these parameters for Open Loop Vector mode.
- ③ Only available or active in either Vector mode. Ignore these parameters for V/F mode.





## Appendix C

---

---

**Remote Keypad Mounting Template**

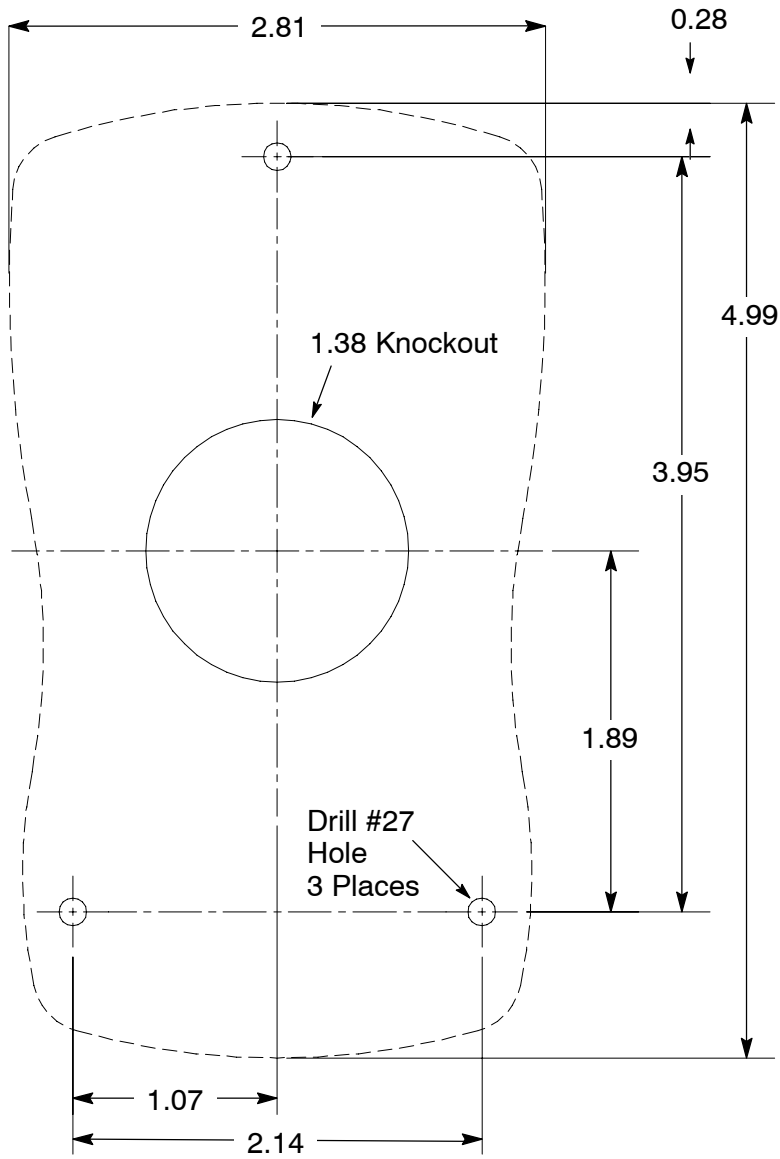

KP0030A00

Note: Template may be distorted due to reproduction.

## Baldor District Offices

### UNITED STATES

#### ARIZONA

PHOENIX  
4211 S 43RD PLACE  
PHOENIX, AZ 85040  
PHONE: 602-470-0407  
FAX: 602-470-0464

#### CALIFORNIA

LOS ANGELES  
6480 FLOTILLA  
COMMERCE, CA 90040  
PHONE: 323-724-6771  
FAX: 323-721-5859

HAYWARD  
21056 FORBES STREET  
HAYWARD, CA 94545  
PHONE: 510-785-9900  
FAX: 510-785-9910

#### COLORADO

DENVER  
2520 W BARBERRY PLACE  
DENVER, CO 80204  
PHONE: 303-623-0127  
FAX: 303-595-3772

#### CONNECTICUT

WALLINGFORD  
65 SOUTH TURNPIKE ROAD  
WALLINGFORD, CT 06492  
PHONE: 203-269-1354  
FAX: 203-269-5485

#### FLORIDA

TAMPA/PUERTO RICO/  
VIRGIN ISLANDS  
3906 EAST 11TH AVENUE  
TAMPA, FL 33605  
PHONE: 813-248-5078  
FAX: 813-247-2984

#### GEORGIA

ATLANTA  
62 TECHNOLOGY DR.  
ALPHARETTA, GA 30005  
PHONE: 770-772-7000  
FAX: 770-772-7200

#### ILLINOIS

CHICAGO  
1601 FRONTENAC ROAD  
NAPERVILLE, IL 60563  
PHONE: 630-848-5100  
FAX: 630-848-5110

#### INDIANA

INDIANAPOLIS  
5525 W. MINNESOTA STREET  
INDIANAPOLIS, IN 46241  
PHONE: 317-246-5100  
FAX: 317-246-5110  
800-428-4141

#### IOWA

DES MOINES  
1800 DIXON STREET, SUITE C  
DES MOINES, IA 50316  
PHONE: 515-263-6929  
FAX: 515-263-6515

#### MARYLAND

BALTIMORE  
6660 SANTA BARBARA RD.  
SUITE 22-24  
ELKRIDGE, MD 21075  
PHONE: 410-579-2135  
FAX: 410-579-2677

#### MASSACHUSETTS

BOSTON  
6 PULLMAN STREET  
WORCESTER, MA 01606  
PHONE: 508-854-0708  
FAX: 508-854-0291

#### MICHIGAN

DETROIT  
33782 STERLING PONDS BLVD.  
STERLING HEIGHTS, MI 48312  
PHONE: 586-978-9800

FAX: 586-978-9969  
MICHIGAN Continued  
GAND RAPIDS  
668 3 MILE ROAD NW  
GRAND RAPIDS, MI 49504  
PHONE: 616-785-1784  
FAX: 616-785-1788

#### MINNESOTA

MINNEAPOLIS  
21080 134TH AVE. NORTH  
ROGERS, MN 55374  
PHONE: 763-428-3633  
FAX: 763-428-4551

#### MISSOURI

ST LOUIS  
422 INDUSTRIAL DRIVE  
MARYLAND HEIGHTS, MO 63043  
PHONE: 314-298-1800  
FAX: 314-298-7660

KANSAS CITY  
915 N W PLATTE VALLEY DR  
RIVERSIDE, MO 64150  
PHONE: 816-587-0272  
FAX: 816-587-3735

#### NEW YORK

AUBURN  
ONE ELLIS DRIVE  
AUBURN, NY 13021  
PHONE: 315-255-3403  
FAX: 315-253-9923

#### NORTH CAROLINA

GREENSBORO  
1220 ROTHERWOOD ROAD  
GREENSBORO, NC 27406  
P O BOX 16500  
GREENSBORO, NC 27416  
PHONE: 336-272-6104  
FAX: 336-273-6628

#### OHIO

CINCINNATI  
2929 CRESCENTVILLE ROAD  
WEST CHESTER, OH 45069  
PHONE: 513-771-2600  
FAX: 513-772-2219

CLEVELAND  
8929 FREEWAY DRIVE  
MACEDONIA, OH 44056  
PHONE: 330-468-4777  
FAX: 330-468-4778

#### OKLAHOMA

TULSA  
2 EAST DAWES  
BIXBY, OK 74008  
PHONE: 918-366-9320  
FAX: 918-366-9338

#### OREGON

PORTLAND  
20393 SW AVERY COURT  
TUALATIN, OR 97062  
PHONE: 503-691-9010  
FAX: 503-691-9012

#### PENNSYLVANIA

PHILADELPHIA  
1035 THOMAS BUSCH  
MEMORIAL HIGHWAY  
PENNSAUKEN, NJ 08110  
PHONE: 856-661-1442  
FAX: 856-663-6363

PITTSBURGH  
616H BEATTY ROAD  
MONROEVILLE, PA 15146  
PHONE: 412-380-7244  
FAX: 412-380-7250

#### TENNESSEE

MEMPHIS  
4000 WINCHESTER ROAD  
MEMPHIS, TN 38118  
PHONE: 901-365-2020  
FAX: 901-365-3914

### TEXAS

HOUSTON  
4647 PINE TIMBERS  
SUITE # 135  
HOUSTON, TX 77041  
PHONE: 713-895-7062  
FAX: 713-690-4540

### DALLAS

3040 QUEBEC  
DALLAS, TX 75247  
PHONE: 214-634-7271  
FAX: 214-634-8874

### UTAH

SALT LAKE CITY  
2230 SOUTH MAIN STREET  
SALT LAKE CITY, UT 84115  
PHONE: 801-832-0127  
FAX: 801-832-8911

### WISCONSIN

MILWAUKEE  
2725 SOUTH 163RD STREET  
NEW BERLIN, WI 53151  
PHONE: 262-784-5940  
FAX: 262-784-1215

### INTERNATIONAL SALES

FORT SMITH, AR  
P.O. BOX 2400  
FORT SMITH, AR 72902  
PHONE: 479-646-4711  
FAX: 479-648-5895

### CANADA

EDMONTON, ALBERTA  
4053-92 STREET  
EDMONTON, ALBERTA T6E 6R8  
PHONE: 780-434-4900  
FAX: 780-438-2600

OAKVILLE, ONTARIO  
2750 COVENTRY ROAD  
OAKVILLE, ONTARIO L6H 6R1  
PHONE: 905-829-3301  
FAX: 905-829-3302

MONTREAL, QUEBEC  
1844 WILLIAM STREET  
MONTREAL, QUEBEC H3J 1R5  
PHONE: 514-933-2711  
FAX: 514-933-8639

VANCOUVER,  
BRITISH COLUMBIA  
1538 KEBET WAY  
PORT COQUITLAM, BC V3C 5M5  
PHONE: 604-421-2822  
FAX: 604-421-3113

WINNIPEG, MANITOBA  
54 PRINCESS STREET  
WINNIPEG, MANITOBA R3B 1K2  
PHONE: 204-942-5205  
FAX: 204-956-4251

### AUSTRALIA

UNIT 3, 6 STANTON ROAD  
SEVEN HILLS, NSW 2147,  
AUSTRALIA  
PHONE: (61) (2) 9674 5455  
FAX: (61) (2) 9674 2495

UNIT 8, 5 KELLETTS ROAD  
ROWVILLE, VICTORIA, 3178  
AUSTRALIA  
PHONE: (61) (3) 9753 4355  
FAX: (61) (3) 9753 4366

BALDOR CENTROAMERICA  
RESIDENCIAL PINARES DE SUIZA  
POL. 15 #44. NVA. SAN SALVADOR  
EL SALVADOR, CENTRO AMERICA  
PHONE: (503) 288-1519  
FAX: (503) 288-1518

BALDOR SUDAMERICA  
CALLE F, EL CANGREJO  
CONDOMINIO P.H. CONDADO PLAZA  
APT. 11D, BELLA VISTA  
PANAMÁ CITY, REP. DE PANAMÁ  
PHONE: (507) 265-6041

### CHINA

SHANGHAI JIAHUA BUSINESS CENTER  
ROOM NO. A-8421  
808 HONG QIAO ROAD  
SHANGHAI 200030  
PHONE: 86-21-64473060  
FAX: 86-21-64078620

### GERMANY

DIESELSTRASSE 22  
D-85551 KIRCHHEIM  
MUNICH, GERMANY  
PHONE: (49) (89) 90508 - 0  
FAX: (49) (89) 90508 - 492

### INDIA

14, COMMERCE AVENUE  
MAHAGANESH COLONY  
PAUD ROAD  
PUNE - 411 038  
MAHARASHTRA, INDIA  
PHONE: 91 20 25 45 95 31/32  
FAX: 91 20 24 55 95 30

### ITALY

BALDOR ASR AG  
SUCCURSALE DI MENDRISIO  
VIA BORROMINI, 20A  
CH-6850 MENDRISIO  
SWITZERLAND  
PHONE: 41 91 640 9952  
FAX: 41 91 630 2633

### JAPAN

DIA BLDG 802,  
2-21-1 TSURUYA-CHO,  
KANAGAWA-KU  
YOKOHAMA, 221-0835, JAPAN  
PHONE: 81-45-412-4506  
FAX: 81-45-412-4507

### KOREA

ROOM 210  
BUPYEONG INDUSTRIAL  
COMMERCIAL COOPERATIVE  
396-16 CHEONGCHEON 2-DONG,  
BUPYEONG-GU  
INCHEON, KOREA, 403-858  
PHONE: 82 32 508 3252  
FAX: 82 32 508 3253

### MÉXICO

KM. 2.0 BLVD. AL AEROPUERTO  
LEÓN 37545, GUANAJUATO, MÉXICO  
PHONE: 52 477 761 2030  
FAX: 52 477 761 2010

### MIDDLE EAST & NORTH AFRICA

YSE INTERNATIONAL CORP.  
3233 NORTH ARLINGTON HEIGHTS  
SUITE 100W  
ARLINGTON HEIGHTS, IL 60004  
PHONE: 847 590 5547

### SINGAPORE

51 KAKI BUKIT ROAD 2  
K B WAREHOUSE COMPLEX  
SINGAPORE 417863  
PHONE: (65) 6 744 2572  
FAX: (65) 6 747 1708

### SWITZERLAND

POSTFACH 73  
SCHUTZENSTRASSE 59  
CH-8245 FEUERTHALEN  
SWITZERLAND  
PHONE: (41) (52) 6474700  
FAX: (41) (52) 6592394

### TAIWAN

4F, NO. 25, SEC. 1,  
TUNHUA S ROAD,  
TAIPEI 10557, TAIWAN, R.O.C.  
PHONE: (886-2) 2577-4352  
FAX: (886-2) 2577-4157

### UNITED KINGDOM

6 BRISTOL DISTRIBUTION PARK  
HAWKLEY DRIVE  
BRISTOL BS32 0BF U.K.  
PHONE: 44 1454 850000  
FAX: 44 1454 859001



**BALDOR ELECTRIC COMPANY**  
**P.O. Box 2400**  
**Ft. Smith, AR 72902-2400**  
**(479) 646-4711**  
**Fax (479) 648-5792**

<b>CH</b> TEL: +41 52 647 4700 FAX: +41 52 659 2394	<b>D</b> TEL: +49 89 90 50 80 FAX: +49 89 90 50 8491	<b>UK</b> TEL: +44 1454 850000 FAX: +44 1454 850001	<b>F</b> TEL: +33 145 10 7902 FAX: +33 145 09 0864
<b>I</b> TEL: +39 11 562 4440 FAX: +39 11 562 5660	<b>AU</b> TEL: +61 29674 5455 FAX: +61 29674 2495	<b>CC</b> TEL: +65 744 2572 FAX: +65 747 1708	<b>MX</b> TEL: +52 477 761 2030 FAX: +52 477 761 2010

**PH1A04**

**Series H2 AC Closed Vector Control**

**MIN741**