

# M DRIVE 23™

MOTOR+DRIVER

## MICROSTEPPING



### FEATURES

- Integrated Microstepping Driver and NEMA 23 High Torque 1.8° Stepping Motor
- Input Voltage:
  - +12 to +48 VDC (MDrive23-4)
  - +24 to +75 VDC (MDrive23-7)
- Low Cost
- Extremely Compact
- Optically Isolated Logic Inputs will Accept +5 to +24 VDC Signals, Sourcing or Sinking†
- Automatic Current Reduction
- Configurable:
  - Motor Run/Hold Current
  - Motor Direction vs. Direction Input
  - Microstep Resolution to 256 Microsteps/Full Step
- Available Configurations:
  - Single Shaft\*
  - Long Life Linear Actuator
  - Optical Encoder\*
  - Control Knob for Manual Positioning\*
  - Integrated Planetary Gearbox\*
- Three Stack Sizes Available\*
- Current and Resolution May Be Switched On-The-Fly
- Single Supply
- Interface Options:
  - Keyed and Locking Pin and Receptacle (C Connector)
  - Pluggable Terminal Strip
  - 12.0" (30.5cm) Flying Leads
- Graphical User Interface (GUI) for Quick and Easy Parameter Setup

\* Rotary Motor Only

† C Connector Version Only. Other Versions Require 5 Volt Sinking Outputs.

### DESCRIPTION

The MDrive NEMA 23 high torque Integrated Motor and Driver is ideal for designers who want the simplicity of a motor with on-board electronics, but without the expense of an indexer on each axis. The low cost MDrive23 allows the system designer to decide the best method of control. The MDrive23's integrated electronics eliminate the need to run the motor cabling through the machine, reducing the potential for problems due to electrical noise.

The MDrive23 uses a NEMA 23 frame size 1.8° high torque stepping motor combined with a microstepping driver, and accepts up to 14 resolution settings from ½ to 256 microsteps per full step. Setup parameters include Microstep Resolution, Motor Run/Hold Current, and Motor Direction with respect to the direction input. These settings may be changed on-the-fly or downloaded and stored in nonvolatile memory with the use of a simple GUI which is provided. This eliminates the need for external switches or resistors. Parameters are changed via an SPI port. Operating voltage for the MDrive23 ranges from +12 to +48 VDC or +24 to +75 VDC.

The versatile, compact MDrive23 is available in multiple configurations to fit various system needs. These include a single shaft rotary motor, a dual shaft rotary motor available with optical encoder or control knob, a planetary gearbox, or a long life Acme screw linear actuator. The rotary MDrive23 is available in single, double and triple stack sizes: 18, 22 & 31. Interface

connections are accomplished using either a 12 position keyed and locking pin and receptacle (C Connector), a 7 position terminal strip, or 12.0" (30.5cm) flying leads.

The MDrive23 is a compact, powerful and inexpensive solution that will reduce system cost, design and assembly time for a large range of stepping motor applications.

### CONFIGURING

The IMS Motor Interface software is an easy to install and use GUI for configuring the MDrive23 from a computer parallel/SPI port. GUI access is via the IMS SPI Interface included on the CD shipped with the product, or download at [www.imshome.com](http://www.imshome.com). Optional cables are available for ease of connecting and configuring the MDrive.

The IMS Motor Interface features:

- Easy installation.
- Automatic detection of MDrive version and communication configuration.
- Will not set out-of-range values.
- Tool-tips display valid range setting for each option.
- Single screen interface (*below*).

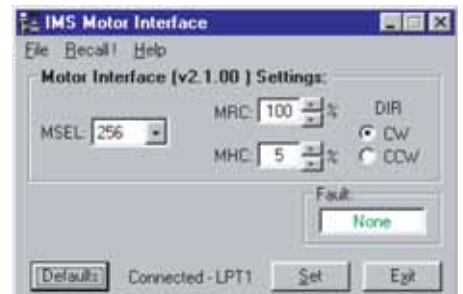

The IMS Motor Interface GUI simplifies MDrive configuring with a single screen interface. (DIR feature with C Connector version only.)

# MDRIVE23 MICROSTEPPING SPECIFICATIONS

## GENERAL SPECIFICATIONS

Input Voltage (+V) Range*	+12 to +48/+24 to +75 VDC
Isolated Inputs	Step Clock, Direction & Enable
Isolated Input Voltage Range (Sourcing or Sinking – C Connector Version Only)	+5 to +24 VDC
Step Frequency (Max)	2 MHz
Steps per Revolution	400, 800, 1000, 1600, 2000, 3200, 5000, 6400, 10000, 12800, 25000, 25600, 50000, 51200
Heat Sink Temperature (Max)	85° C
Motor Temperature (Max)	100° C

\* Graph illustrates power supply current requirements (maximum) per MDrive23. Actual power supply current will depend on voltage and load.

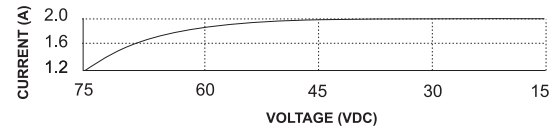

## PARAMETERS

SETUP PARAMETERS				
NAME	FUNCTION	RANGE	UNITS	DEFAULT
MHC	Motor Hold Current	0 to 100	percent	5
MRC	Motor Run Current	1 to 100	percent	25
MSEL	Microstep Resolution	2, 4, 5, 8, 10, 16, 25, 32, 50, 64, 125, 128, 250, 256	µsteps per step	256
DIR	Motor Direction Override <i>C Connector Version ONLY</i>	0/1	--	CW

All parameters are set using the supplied IMS Motor Interface GUI and may be changed on-the-fly. An optional Parameter Setup Cable is recommended with first orders.

## PIN/WIRE ASSIGNMENTS

### C Connector

CONNECTOR P1	
PIN	FUNCTION
1	POWER GROUND
2	+V (+12 TO +48/+24 TO +75 VDC)
3	OPTOCOUPLER REFERENCE
4	STEP CLOCK INPUT
5	ENABLE INPUT
6	CW / CCW DIRECTION INPUT
7	+5 VDC OUTPUT
8	SPI CLOCK
9	COMMUNICATIONS GROUND
10	SPI MASTER IN - SLAVE OUT
11	SPI CHIP SELECT
12	SPI MASTER OUT - SLAVE IN

### Pluggable Terminal Strip or Flying Leads

CONNECTOR P1		
PIN	FLYING LEADS	FUNCTION
1	White	+5 VDC OPTOCOUPLER SUPPLY
2	--	NO CONNECT
3	Orange	STEP CLOCK INPUT
4	Blue	CW / CCW DIRECTION INPUT
5	Brown	ENABLE INPUT
6	Black	POWER GROUND
7	Red	+V (+12 TO +48/+24 TO +75 VDC)

CONNECTOR P2 (SPI) – 10 Pin Pin-Header	
PIN	FUNCTION
1	NO CONNECT
2	NO CONNECT
3	NO CONNECT
4	CHIP SELECT
5	GROUND
6	+5 VDC OUTPUT
7	MASTER OUT - SLAVE IN
8	CLOCK
9	NO CONNECT
10	MASTER IN - SLAVE OUT

## ENCODER PIN ASSIGNMENTS

ENCODER – Single-End	
PIN	FUNCTION
1	GROUND
2	INDEX
3	CHANNEL A
4	+5 VDC INPUT
5	CHANNEL B

ENCODER – Differential			
PIN		FUNCTION	
1		NO CONNECT	
2		+5 VDC INPUT	
3		GROUND	
4		NO CONNECT	
5		CHANNEL A –	
	6		CHANNEL A +
	7		CHANNEL B –
	8		CHANNEL B +
	9		INDEX –
	10		INDEX +

Optional Encoder Cables available.

NOTE: For recommended mating connector information, refer to the product's Quick Reference at [www.imshome.com/quick.html](http://www.imshome.com/quick.html)

# MDRIVE23 MOTOR SPECIFICATIONS

## MD2218 Single Stack

Holding Torque ..... 90 oz-in / 64 N-cm  
 Detent Torque ..... 3.9 oz-in / 2.7 N-cm  
 Rotor Inertia ..... 0.0025 oz-in-sec<sup>2</sup> / 0.18 kg-cm<sup>2</sup>  
 Weight (Motor+Driver)..... 20.1 oz / 569.8 g

## MD2222 Double Stack

Holding Torque ..... 144 oz-in / 102 N-cm  
 Detent Torque ..... 5.6 oz-in / 3.92 N-cm  
 Rotor Inertia ..... 0.0037 oz-in-sec<sup>2</sup> / 0.26 kg-cm<sup>2</sup>  
 Weight (Motor+Driver)..... 24.4 oz / 691.7 g

## MD2231 Triple Stack

Holding Torque ..... 239 oz-in / 169 N-cm  
 Detent Torque ..... 9.7 oz-in / 6.86 N-cm  
 Rotor Inertia ..... 0.0065 oz-in-sec<sup>2</sup> / 0.46 kg-cm<sup>2</sup>  
 Weight (Motor+Driver)..... 38.5 oz / 1091.5 g

## MD2218 Linear Actuator

Maximum Thrust ..... 200 lbs / 890 N  
 Maximum Screw Deflection ..... ± 1°  
 Backlash ..... 0.005 in / 0.127 mm  
 Weight (without screw)..... 20.4 oz / 578.3 g

### TORQUE-SPEED CURVES

#### Rotary Motor

##### MD2218 Single Stack

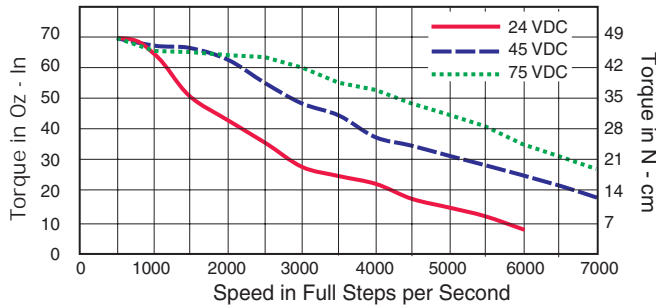

##### MD2222 Double Stack

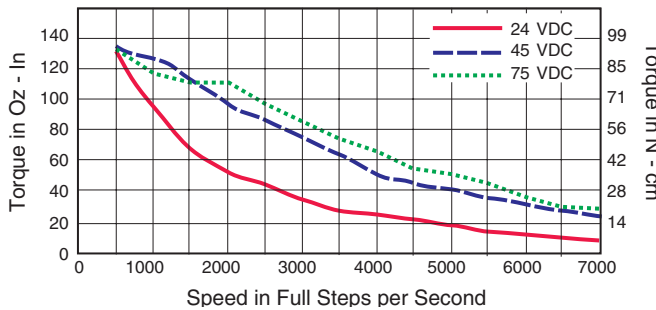

##### MD2231 Triple Stack

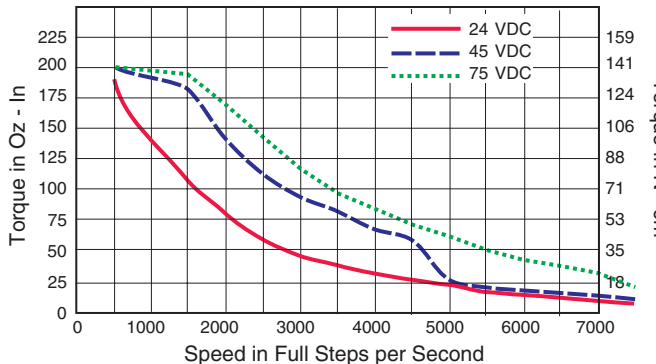

### FORCE-SPEED CURVES

#### Linear Actuator

##### 24 VDC

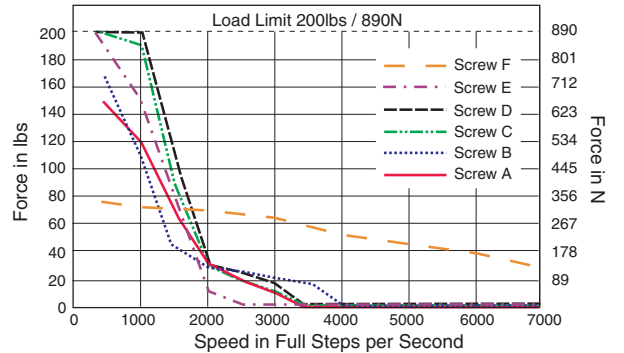

##### 45 VDC

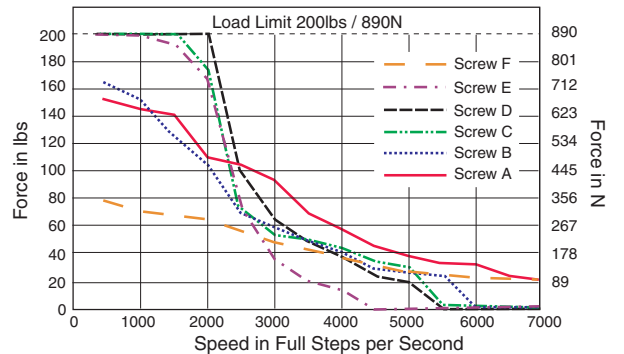

##### 75 VDC

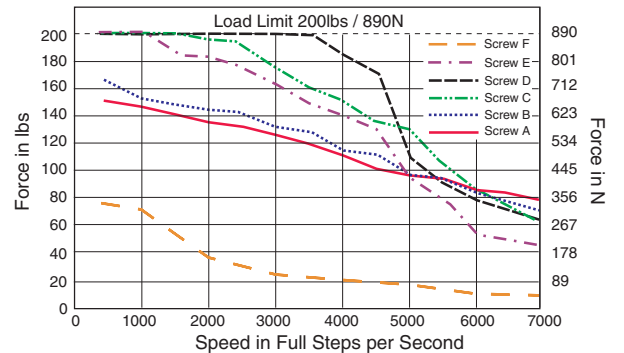

## MDRIVE23 WITH PLANETARY GEARBOX

The MDrive23 is available with a Planetary Gearbox option developed to increase torque at lower speeds, enable better inertia matching and produce finer positional resolutions. These efficient, low maintenance Planetary Gearbox come fully assembled with the MDrive and are offered in a large number of

reduction ratios in 1-, 2- and 3-stage configurations. An optional NEMA Flange allows mounting the Planetary Gearbox to the load using a standard NEMA bolt circle. Planetary Gearbox may be combined with other MDrive23 options, however are unavailable on Linear Actuator versions.

### Parameters

	1-Stage	2-Stage	3-Stage
Permitted Output Torque (oz-in/Nm)	566/4.0	1699/12.0	3540/25.0
Gearbox Efficiency	0.80	0.75	0.70
Maximum Backlash (degree)	0.70°	0.75°	0.80°

### Output Side with Ball Bearing

Maximum Load, Radial (lb-force/N)	45/200	72/320	101/450
Maximum Load, Axial (lb-force/N)	13/60	22/100	34/150
Weight - Gearbox Only (oz/g)	25.0/711	32.2/914	39.4/1117
Weight - Gearbox & NEMA Flange (oz/g)	25.9/735	33.3/945	40.7/1155

## PLANETARY GEARBOX MECHANICAL SPECIFICATIONS

Dimensions in Inches (mm)

### Planetary Gearbox for MDrive23

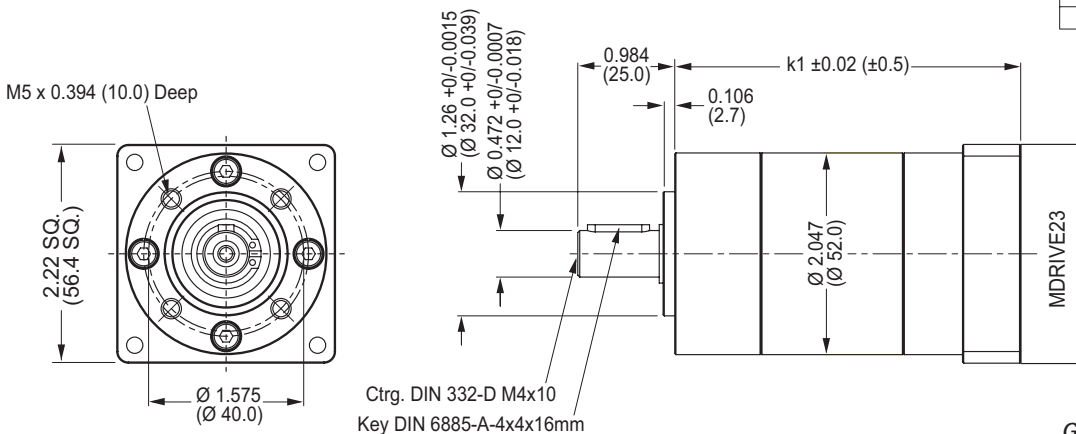

### Gearbox Ratios (Rounded)

1-Stage	2-Stage	3-Stage
3.70:1	13.73:1	50.89:1
5.18:1	15.88:1	58.85:1
6.75:1	18.36:1	68.06:1
19.20:1	71.16:1	
22.20:1	78.71:1	
25.01:1	92.70:1	
26.85:1	95.17:1	
28.93:1	99.50:1	
34.97:1	107.20:1	
45.56:1	115.07:1	
123.97:1		
129.62:1		
139.13:1		
149.90:1		
168.84:1		
181.24:1		
195.26:1		
236.09:1		
307.54:1		

### Gearbox Lengths Inches (mm)

	1-Stage	2-Stage	3-Stage
k1 Gearbox	4.315 (109.6)	5.169 (131.3)	6.024 (153.0)
k2 Gearbox w/ NEMA Flange	4.433 (112.6)	5.287 (134.3)	6.142 (156.0)

### Planetary Gearbox with Optional NEMA Output Flange

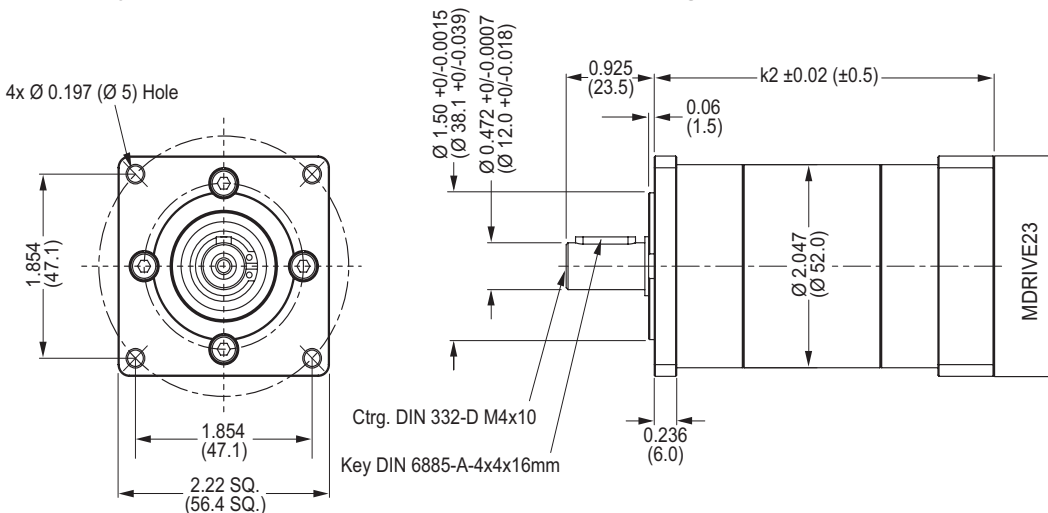

# MDRIVE23 MICROSTEPPING – MECHANICAL SPECIFICATIONS

Dimensions in Inches (mm)

## Rotary MDrive23: Single Shaft, Control Knob & Encoder Versions

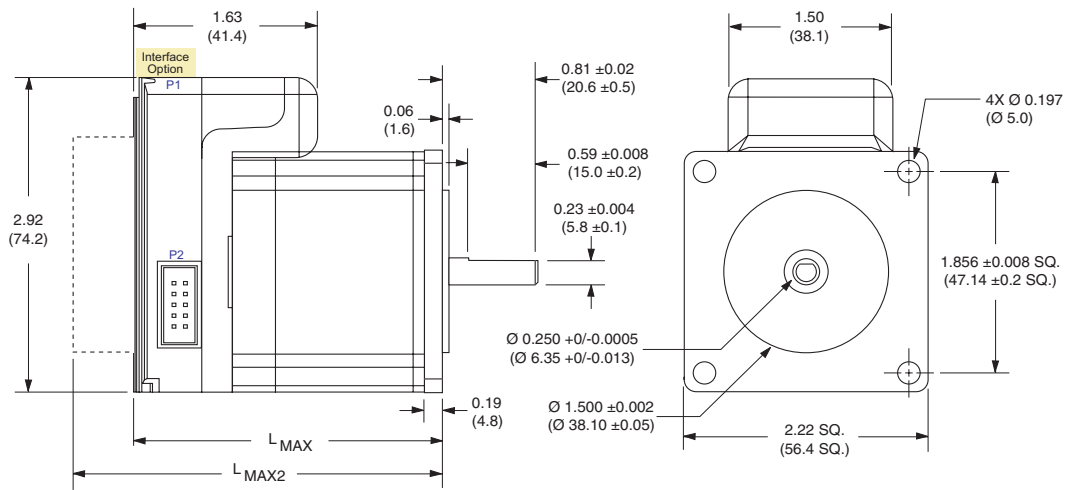

### MDrive Lengths Inches (mm)

Stack Size	L <sub>MAX</sub>		L <sub>MAX2</sub>	
	SINGLE SHAFT VERSION		CONTROL KNOB or ENCODER VERSION	
2218	2.63	(66.8)	3.35	(85.1)
2222	3.00	(76.2)	3.70	(94.0)
2231	3.86	(98.0)	4.57	(116.1)

### Interface Options

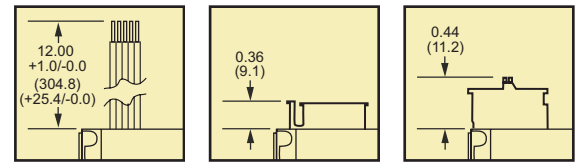

### L<sub>MAX2</sub> Options

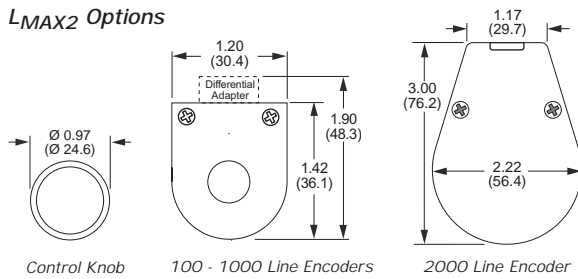

## Linear Actuator MDrive23

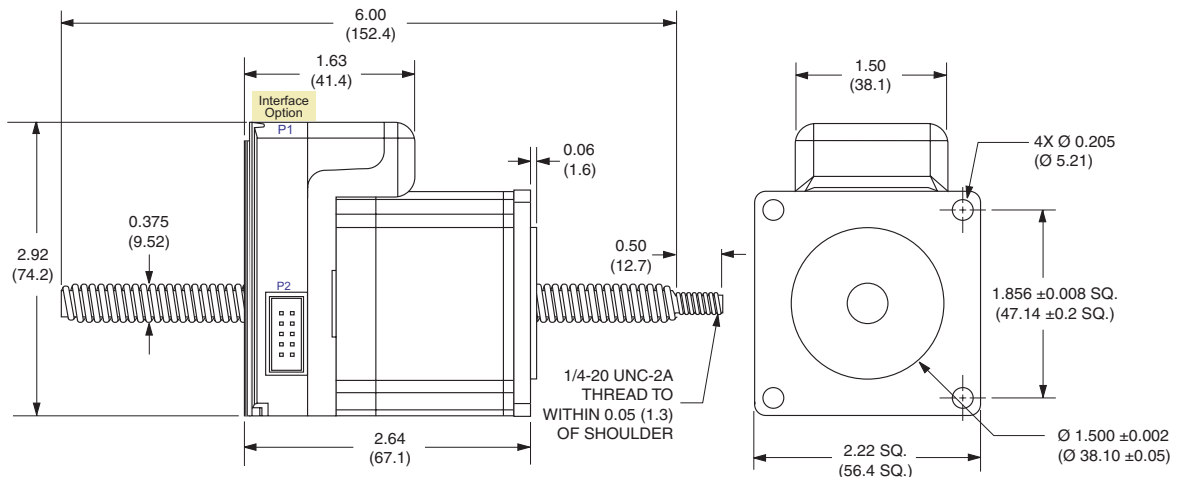

## MDRIVE23 MICROSTEPPING – OPTIONS

### Control Knob

The MDrive23 is available with a factory-mounted rear control knob for manual shaft positioning.

### Planetary Gearbox

Efficient, low maintenance Planetary Gearbox are offered assembled with the MDrive23. Details inside.

### Encoder

The MDrive23 is available with a factory-mounted optical encoder. Available line counts are 100, 200, 250, 400, 500, 1000 or 2000. All encoders, except 1000 line, have an index mark. Encoders are available in both single-end and differential configurations. Order optional Encoder Cables separately:

Single-end Cable (12"/30.5cm) ... ES-CABLE-2\*

Differential Cable (36"/91.5cm)... ED-CABLE-2\*

\*Change "2" to a "6" when ordering 2000 line encoder cable.

### Linear Actuator

The MDrive23 with long life Acme Screw Linear Actuator is available with the following travel/full step:

Screw F .....0.002"/full step

Screw A .....0.001"/full step

Screw B .....0.0008333"/full step

Screw C .....0.0005"/full step

Screw D .....0.0004167"/full step

Screw E .....0.0003125"/full step

Standard screw length is 6.0" (152.4mm) plus the mounting end thread. Custom lengths from 2.0" to 24.0" are available without mounting end thread.

Linear Actuators are Non-Captive style. Contact the factory regarding Captive Shaft or External styles.

### Parameter Setup Cable and Adapter

The optional 6' (1.8m) Parameter Setup Cable Part No. MD-CC100-000 eliminates the need to wire communications and is recommended with first order. It connects an MDrive's 10 pin pin-header (P2) to a standard DB-25 PC Parallel/SPI port and includes built-in logic level shifting circuitry to accommodate the 3.3v ports on some PCs. In addition, MDrives with C Connector require an Adapter Part No. MD-ADP-1723C to mate the Cable to the 12 position pin and receptacle connector (P1).

### Prototype Development Cable

For testing and development of MDrives with C Connector, the 12" (30.5cm) Prototype Development Cable plugs into the MD-ADP-1723C Adapter and has flying leads for connection to the user interface. Part No. ADP-3512-FL.

## ORDER INFORMATION

MDRIVE23 MICROSTEPPING	
Stack Sizes 18† = Single Stack & Linear Actuator 22 = Double Stack 31 = Triple Stack	
<b>MDM</b> <input type="checkbox"/> <b>22</b> <input type="checkbox"/> - <input type="checkbox"/> <b>OPTION</b> <input type="checkbox"/>	
Interface Options C = Pin & Receptacle* F = 12" Flying Leads P = Pluggable Clamp Type Terminal Strip	Input Voltage 4 = 48 VDC 7 = 75 VDC*
<b>Example #1:</b> Part Number <b>MDMC2222-4</b> is an <b>MDrive23</b> Microstepping with <b>C</b> Connector, <b>NEMA 22</b> motor, stack size <b>22</b> and +12 to +48 VDC input voltage range.	

OPTIONS	
<b>Control Knob</b> <b>N</b> <input type="checkbox"/>	<b>Example #2: MDMC2222-4N</b> Adds a Control Knob to the part shown in example #1.
<b>Planetary Gearbox</b> <b>G</b> <input type="checkbox"/> <input type="checkbox"/> Gearbox Ratio Rounded to Nearest Whole Number	<b>Example #3: MDMC2222-4G5</b> Rounding ratio to the nearest whole number, the above adds a Planetary Gearbox with 5.18:1 ratio to the part shown in example #1. Add -F if optional NEMA Flange is desired.
<b>Encoder</b> <b>E</b> <input type="checkbox"/> <input type="checkbox"/> S = Single End D = Differential Line Count: 100, 200, 250, 400, 500, 1000, 2000	<b>Example #4: MDMC2222-4ED500</b> Adds a 500 line count Differential Encoder to the part shown in example #1.
<b>Linear Actuator†</b> <b>L</b> <input type="checkbox"/> <input type="checkbox"/> <input type="checkbox"/> Screw Type (Travel/Full Step) F = 0.002" A = 0.001" B = 0.0008333" C = 0.0005" D = 0.0004167" E = 0.0003125" Custom Screw Length Range 2.0" to 24.0" Format XX.X eg. 08.5 for an 8.5" Screw (6.0" Screw Length Standard)	<b>Example #5: MDMC2218-4LB10.5</b> MDrive23 Microstepping Linear Actuator with a 0.0008333"/Full Step Acme Screw custom cut to 10.5". MAY NOT be combined with other options. <i>Note: MDrive23 Linear Actuator Available ONLY in Stack Size 18</i>

†Linear Actuator Available **ONLY** in Stack Size 18. (MDMX2218LX)

\*MDrive 75 Volt version NOT Available with C Connector Interface Option.



P.O. Box 457, 370 N. Main Street  
Marlborough, CT 06447 U.S.A.

Phone: 860/295-6102  
Fax: 860/295-6107  
E-mail: info@imshome.com  
Home Page: www.imshome.com

Distributed By:

### TECHNICAL SUPPORT

**Eastern U.S.**  
Phone: 860/295-6102  
Fax: 860/295-6107  
E-mail: etech@imshome.com  
**Western U.S.**  
Phone: 760/966-3162  
Fax: 760/966-3165  
E-mail: wtech@imshome.com

### IMS MOTORS DIVISION

105 Copperwood Way, Suite H  
Oceanside, CA 92054  
Phone: 760/966-3162  
Fax: 760/966-3165  
E-mail: motors@imshome.com

### IMS EUROPE GmbH

Hahnstrasse 10, VS-Schwenningen  
Germany D-78054  
Phone: +49/7720/94138-0  
Fax: +49/7720/94138-2  
E-mail: info@imseuropehome.com

### European Sales Management

4 Quai Des Etoiles  
69005 Lyon, France  
Phone: +33/4 7256 5113  
Fax: +33/4 7838 1537  
E-mail: bmartinez@imshome.com

### German Sales/Technical Support

Phone: +49/35205/4587-8  
Fax: +49/35205/4587-9  
E-mail: hruhland@imshome.com

Product information covered by IMS Product Disclaimer available at www.imshome.com. Visit the IMS web site for the most up-to-date product information.

© 2002, 2004 Intelligent Motion Systems, Inc. All Rights Reserved.

REV121704